

### SpicePlus

Like spice, its diminutive size is a stark contrast to its standout performance in terms of brightness, durability and reliability. Despite being the smallest in size yet the SpicePlus packs a powerful performance and is a highly reliable design device.



### Features:

- > Super high brightness surface mount LED automotive exterior applications.
- > 120° viewing angle.
- > Compact package outline (LxW) of 2.5 x 2.0mm.
- > Ultra low height profile - 0.7mm.
- > Low thermal resistance.
- > Superior corrosion robustness.
- > Compatible to IR reflow soldering.
- > Compliance to automotive standard; AEC-Q102.
- > Environmental friendly; RoHS compliance.



### Applications:

- > Automotive: Exterior application: eg: Turn Signal, Rear Combination Light (RCL), Center High Mounted Stop Light (CHMSL).



**Optical Characteristics at Tj=25°C**

Part Number	Color	Viewing Angle°	Luminous Flux @ 200mA (lm) <i>Appx. 1.2</i>		
			Min.	Typ.	Max.
SVS-SHG-NP3-3	Super Red, 635 nm	120	18.1	23.5	30.6
SVS-SHG-NP9-3	Super Red, 635 nm	120	19.3	25.0	32.7
SVS-SHG-N3Q2-2	Super Red, 630 nm	120	20.6	26.8	34.8
SVS-SHG-N9Q8-2	Super Red, 630 nm	120	22.0	28.7	37.3
SVA-SHG-P3R2-4	Amber, 625 nm	120	26.8	34.8	45.2
SVA-SHG-P9R8-4	Amber, 625 nm	120	28.7	37.3	48.5
SVA-SHG-Q3S2-2	Amber, 617 nm	120	34.8	45.2	59.0
SVA-SHG-Q9S8-2	Amber, 617 nm	120	37.3	48.5	63.0
SVY-SHG-QR3-4	Yellow, 592 nm	120	30.6	39.8	51.7
SVY-SHG-Q9S8-4	Yellow, 592 nm	120	37.3	48.5	63.0
SVY-SHG-P3R2-3	Yellow, 589 nm	120	26.8	34.8	45.2
SVY-SHG-QR9-3	Yellow, 589 nm	120	32.7	42.5	55.4
SVY-SHG-PQ3-2	Yellow, 586 nm	120	23.5	30.6	39.8
SVY-SHG-P9R8-2	Yellow, 586 nm	120	28.7	37.3	48.5

**Optical Characteristics at Tj=25°C**

Part Number	Color	Viewing Angle°	Luminous Flux @ 200mA (lm) <i>Appx. 1.2</i>		
			Min.	Typ.	Max.
● SVS-SHG-M3P2-3	Super Red, 635 nm	120	15.8	20.6	26.8
● SVS-SHG-NP3-2	Super Red, 630 nm	120	18.1	23.5	30.6
● SVA-SHG-PQ3-4	Amber, 625 nm	120	23.5	30.6	39.8
● SVA-SHG-QR3-2	Amber, 617 nm	120	30.6	39.8	51.7
● SVY-SHG-P3R2-4	Yellow, 592 nm	120	26.8	34.8	45.2
● SVY-SHG-PQ3-3	Yellow, 589 nm	120	23.5	30.6	39.8
● SVY-SHG-N3Q2-2	Yellow, 586 nm	120	20.6	26.8	34.8
● Not for new design					

**Electrical Characteristics at Tj=25°C**

Part Number	Vf @ If = 200mA <i>Appx. 3.1</i>			Vr @ Ir = 10uA <i>Appx. 7.1</i>
	Min. (V)	Typ. (V)	Max. (V)	Min. (V)
SVx-SHG (except Yellow)	2.05	2.35	2.65	12
SVY-SHG	2.05	2.40	2.65	12

**Absolute Maximum Ratings**

	Maximum Value	Unit
DC forward current	250	mA
Peak pulse current; (Ts = 55°C, tp ≤ 100µs, Duty cycle = 0.03)	500	mA
Reverse voltage <i>Appx. 7.1</i>	12	V
ESD threshold (HBM)	2	KV
LED junction temperature	150	°C
Operating temperature	-40 ... +125	°C
Storage temperature	-40 ... +125	°C
Thermal resistance (Rated current = 200mA, Ts = 25 °C)		
- Real Thermal Resistance Junction / solder point, R <sub>th JS real</sub>		
Super Red & Amber (typ = 17)	23	K/W
Yellow (typ = 20)	25	K/W
- Electrical Thermal Resistance Junction / solder point, R <sub>th JS el</sub>		
Super Red & Amber (typ = 10)	14	K/W
Yellow (typ = 17)	21	K/W

**Wavelength Grouping at Tj= 25°C**

Color	Group	Wavelength distribution (nm) <small>Appx. 2.2</small>
SVx; Super Red	Full	627 - 637
	W	627 - 630
	X	630 - 633
	Y	633 - 637
SVx; Amber	Full	612 - 627
	W	612 - 616
	X	616 - 620
	Y	620 - 624
	Z	624 - 627
SVx; Yellow	Full	583 - 595
	W	583 - 586
	X	586 - 589
	Y	589 - 592
	Z	592 - 595

**Luminous Flux Group at Tj=25°C**

Brightness Group	Luminous Flux (lm) <small>Appx. 1.2</small>
M3	15.8 ... 18.1
N2	18.1 ... 20.6
N3	20.6 ... 23.5
P2	23.5 ... 26.8
P3	26.8 ... 30.6
Q2	30.6 ... 34.8
Q3	34.8 ... 39.8
R2	39.8 ... 45.2
R3	45.2 ... 51.7
S2	51.7 ... 59.0
N8	19.3 ... 22.0
N9	22.0 ... 25.0
P8	25.0 ... 28.7
P9	28.7 ... 32.7
Q8	32.7 ... 37.3
Q9	37.3 ... 42.5
R8	42.5 ... 48.5
R9	48.5 ... 55.4
S8	55.4 ... 63.0

**Vf Bining (Optional)**

Vf Bin @ 200 mA	Forward Voltage (V) <i>Appx. 4.1</i>
V44	2.05 ... 2.20
V45	2.20 ... 2.35
V46	2.35 ... 2.50
V47	2.50 ... 2.65

Please consult sales and marketing for special part number to incorporate Vf binning.

**Relative Luminous Flux Vs Forward Current** *Appx. 4.1*

$\Phi_V/\Phi_V(200mA) = f(I_F); T_j = 25^\circ C$

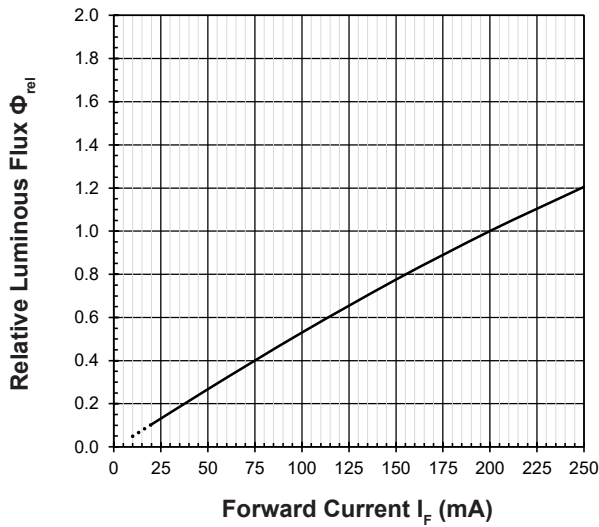

**Forward Current Vs Forward Voltage** *Appx. 4.1*

$I_F = f(V_F); T_j = 25^\circ C$

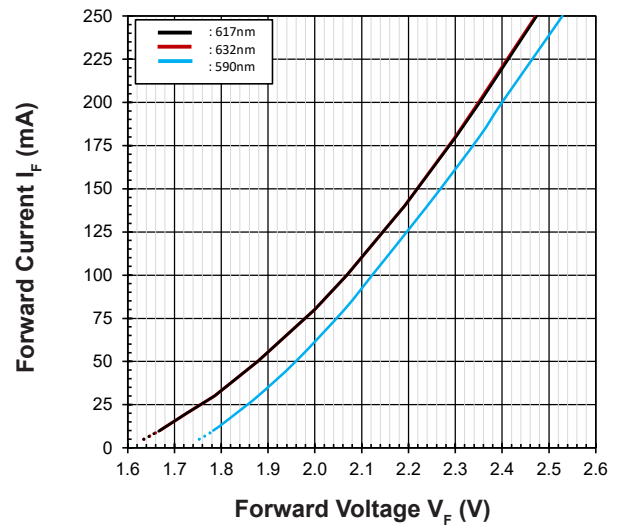

**Maximum Current Vs Temperature**

$I_F = f(T)$

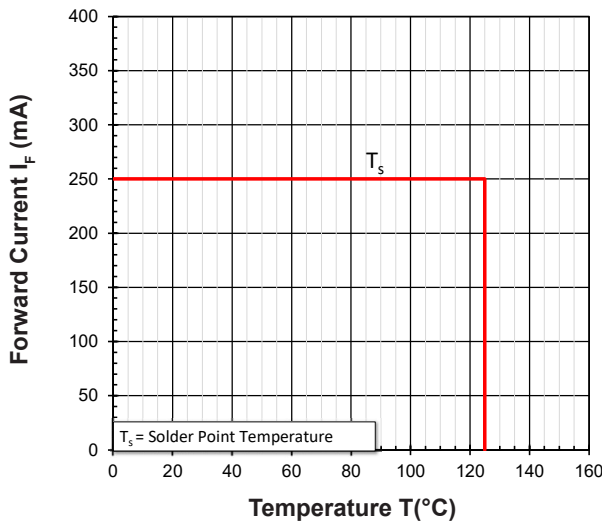

**Relative Spectral Emission** *Appx. 4.1*

$\Phi_{rel} = f(\lambda); T_j = 25^\circ C; I_F = 200mA$

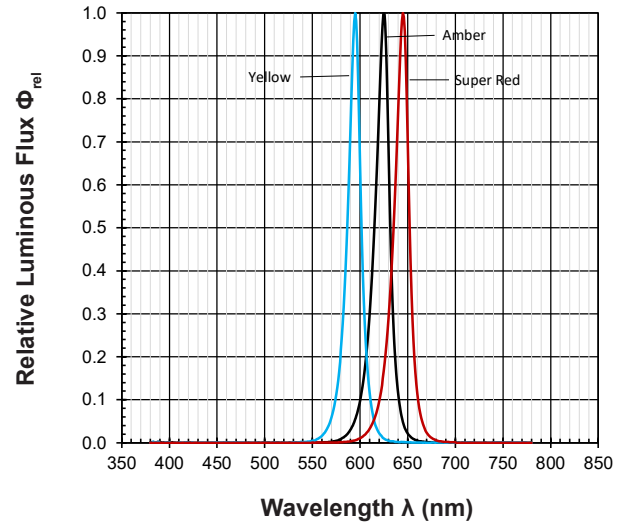

**Allowable Forward Current Vs Duty Ratio**

$(T_s = 55^\circ C; t_p \le 100\mu s)$

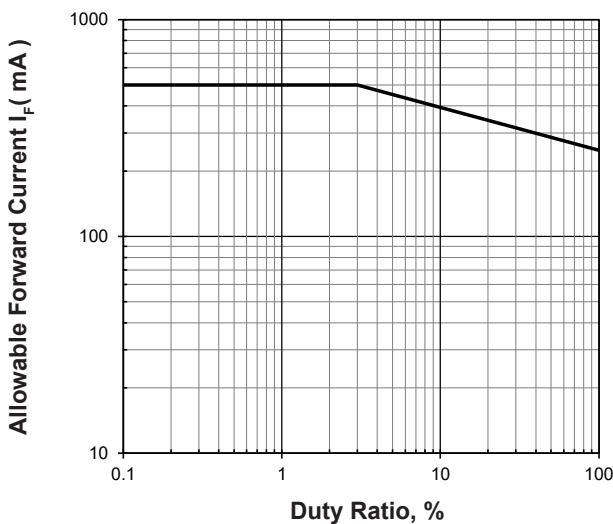

**Radiation Pattern** *Appx. 4.1*

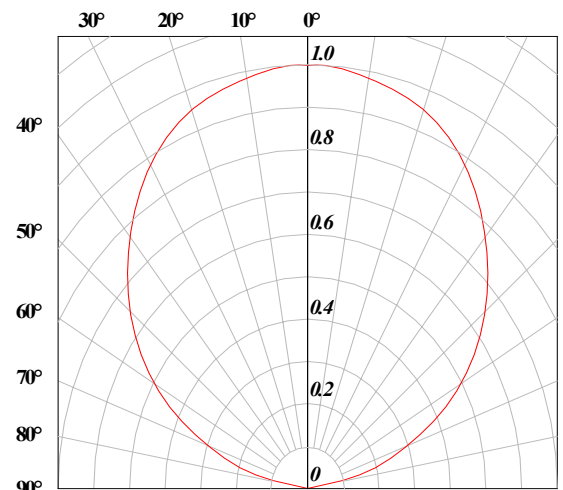

**Forward Voltage Vs Junction Temperature** *Appx. 4.1*

$$\Delta V_F = V_F - V_F(25^\circ\text{C}) = f(T_j); I_F = 200\text{mA}$$

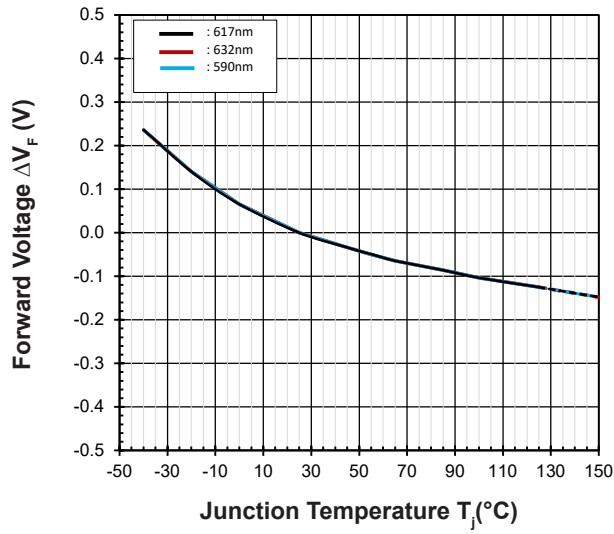

**Relative Luminous Flux Vs Junction Temperature** *Appx. 4.1*

$$\Phi_V/\Phi_V(25^\circ\text{C}) = f(T_j); I_F = 200\text{mA}$$

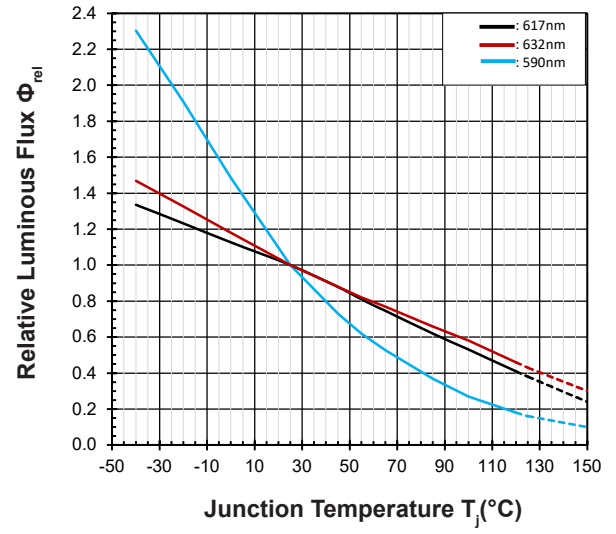

**Wavelength Vs Junction Temperature** *Appx. 4.1*

$$\Delta\lambda_{\text{dom}} = \lambda_{\text{dom}} - \lambda_{\text{dom}}(25^\circ\text{C}) = f(T_j); I_F = 200\text{mA}$$

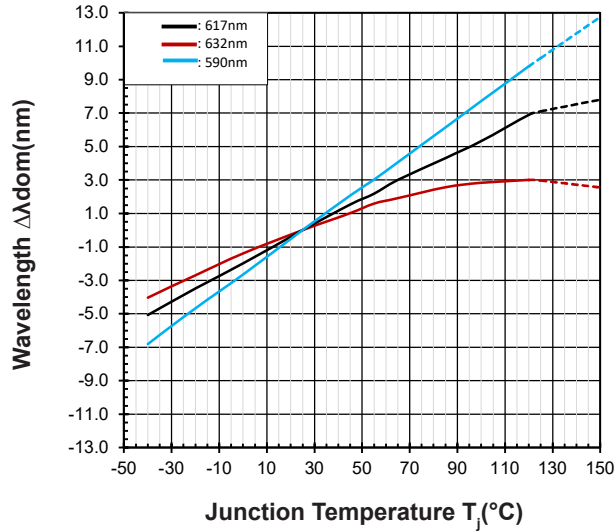

**SpicePlus 2520 AllnGaP : SVx-SHG Package Outlines** *Appx. 5.1*

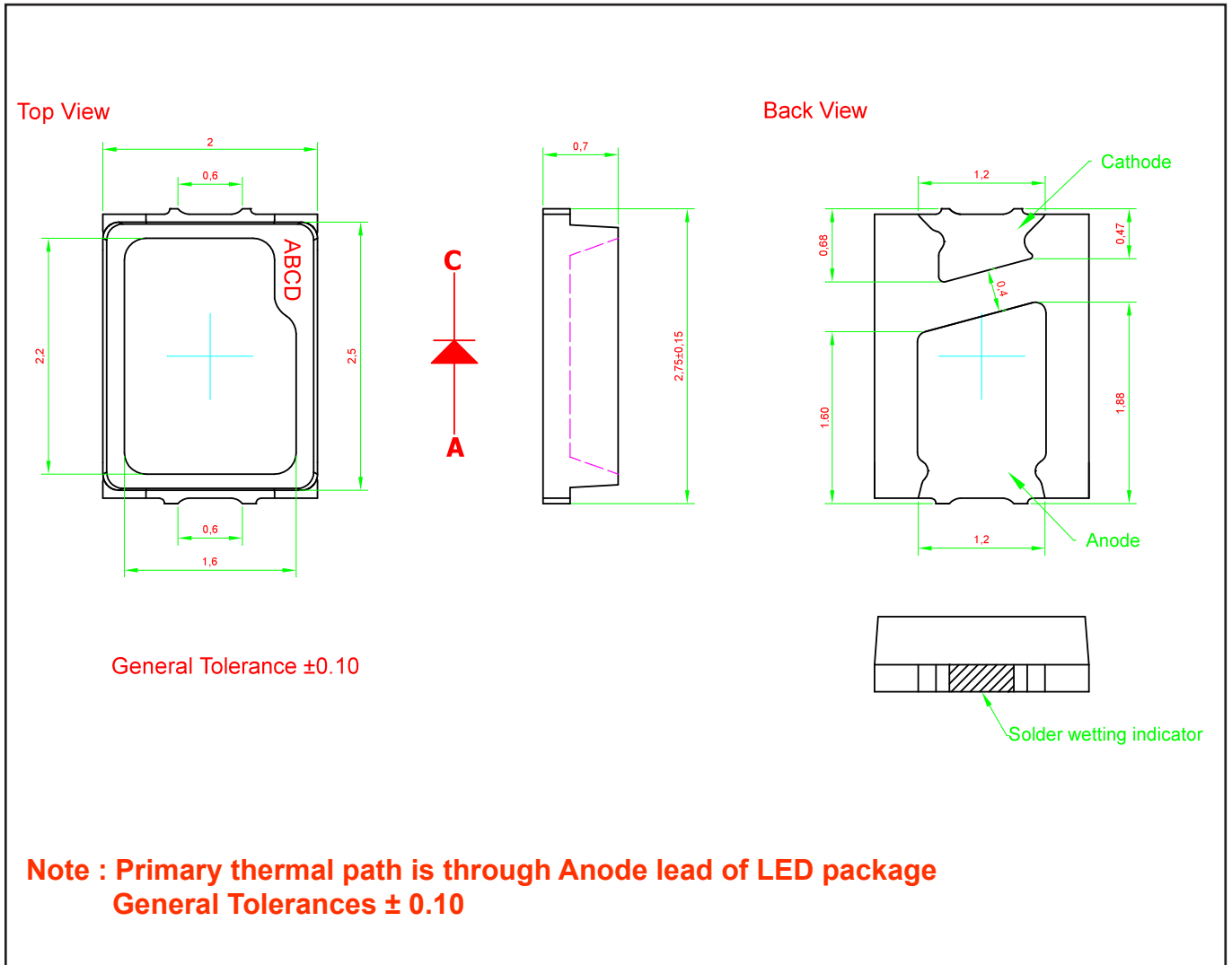

**Material**

Material	
Lead-frame	Cu Alloy With Au Plating
Package	High Temperature Resistant Plastic
Encapsulant	Silicone Resin
Soldering Leads	Sn Plating



Taping and orientation Appx. 5.1

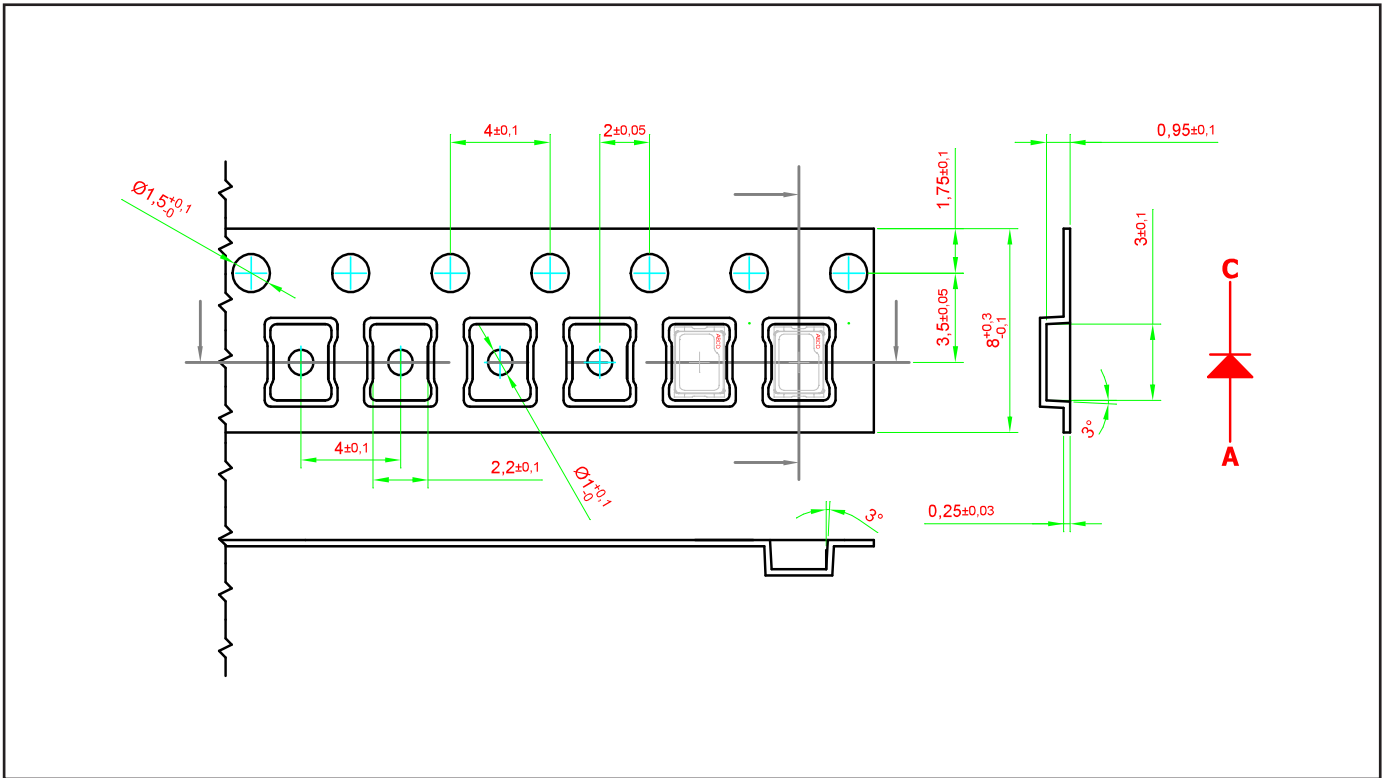

**Packaging Specification**

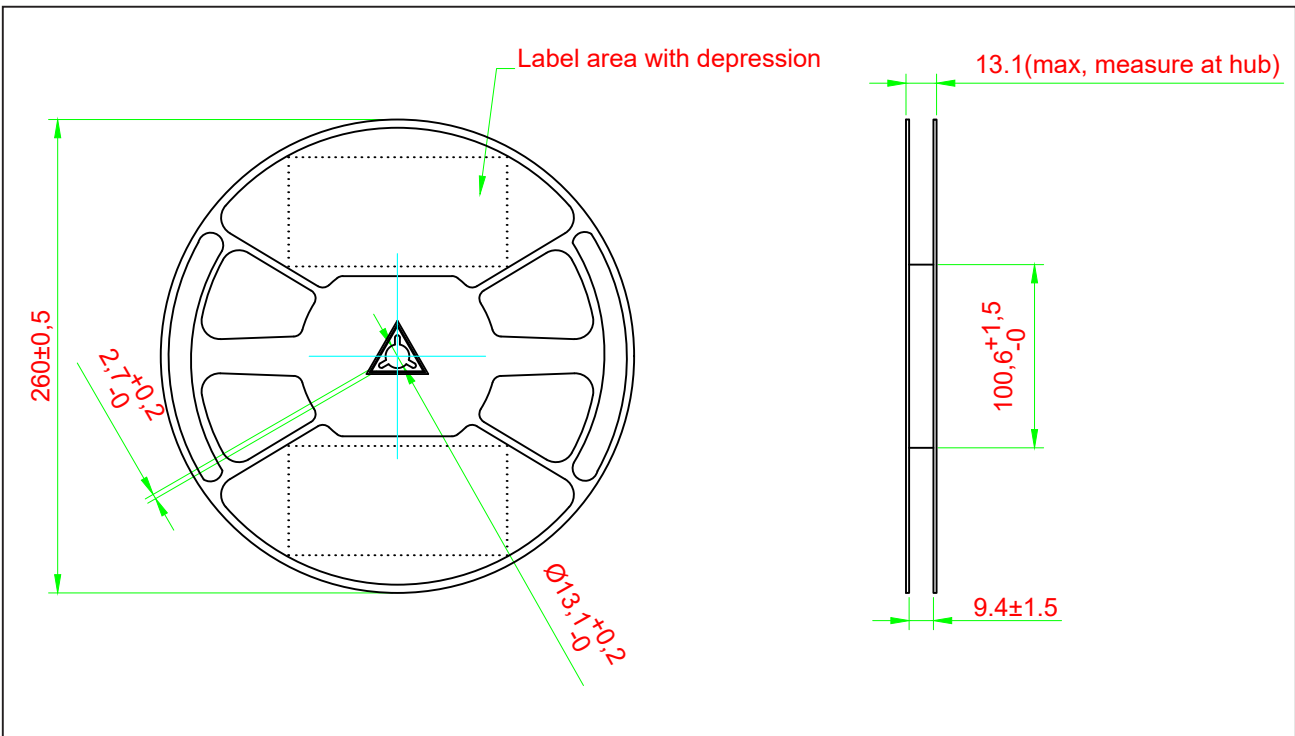
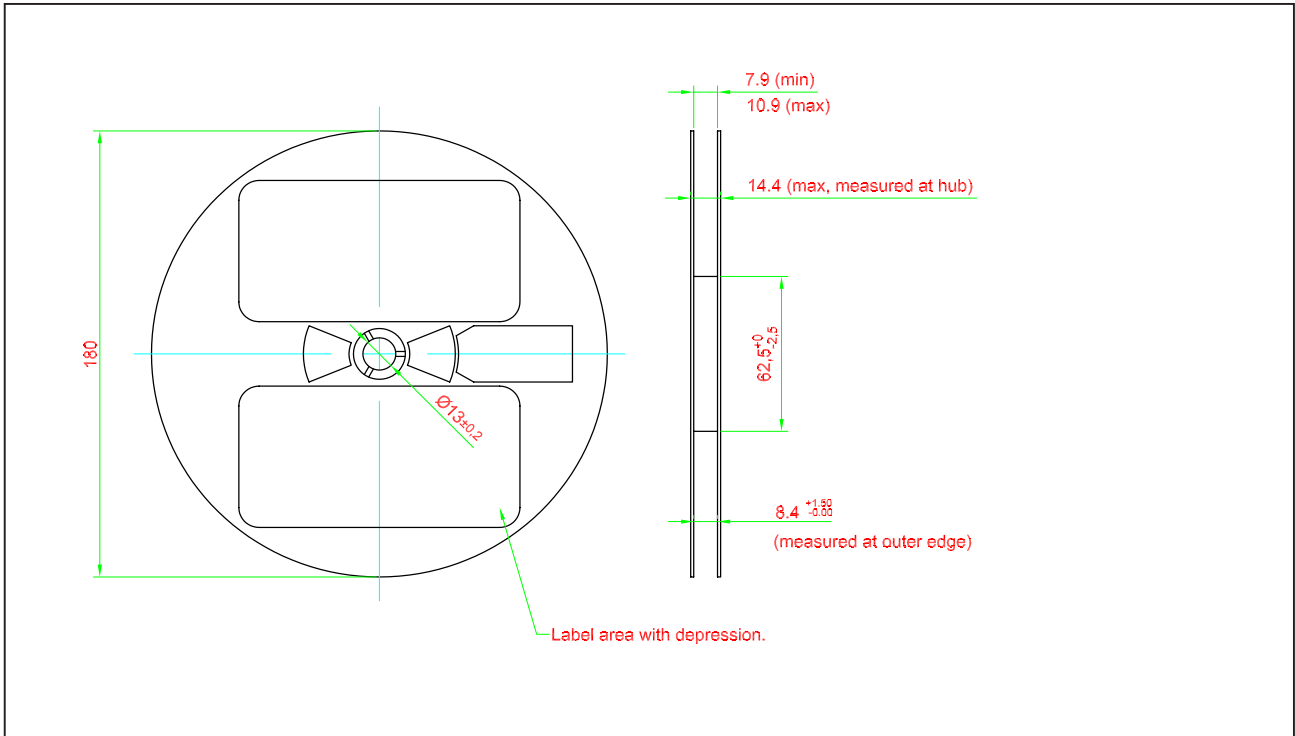

	Reel Diameter (mm)	Quantity (pcs)	*Ordering Number
Standard Packing	180	4000	SVx-SHG-xxx-x
Optional Packing	260	8000	SVx-SHG-xxx-x-8

Notes:

\* For ordering purpose only. Please consult sales and marketing for details.

## Packaging Specification

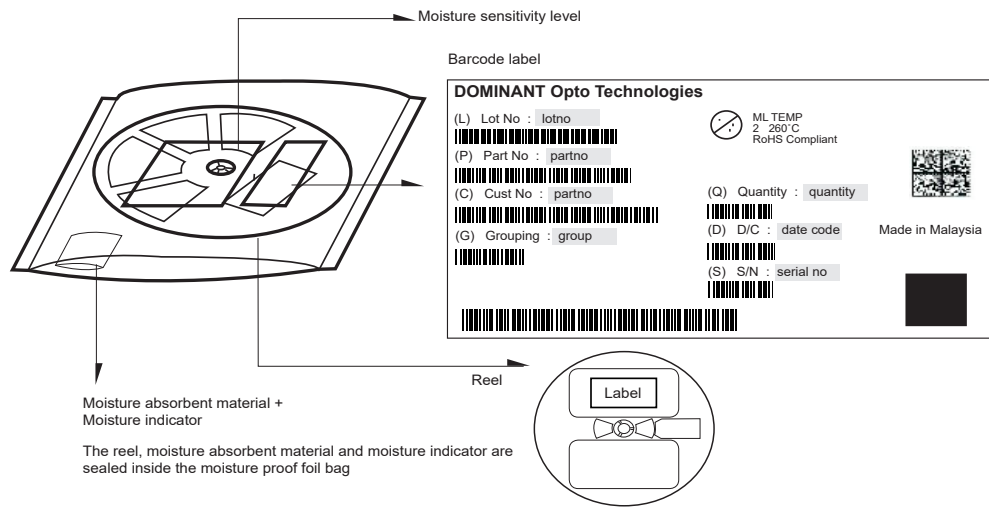

Quantity per bag (pcs)	Average 1pc SpicePlus 2520 (g)	1 completed bag (g)
4000	0.0089	150 ± 10
8000	0.0089	360 ± 10

## Recommended Pb-free Soldering Profile

Product complies to MSL Level 2 acc. to JEDEC J-STD-020E

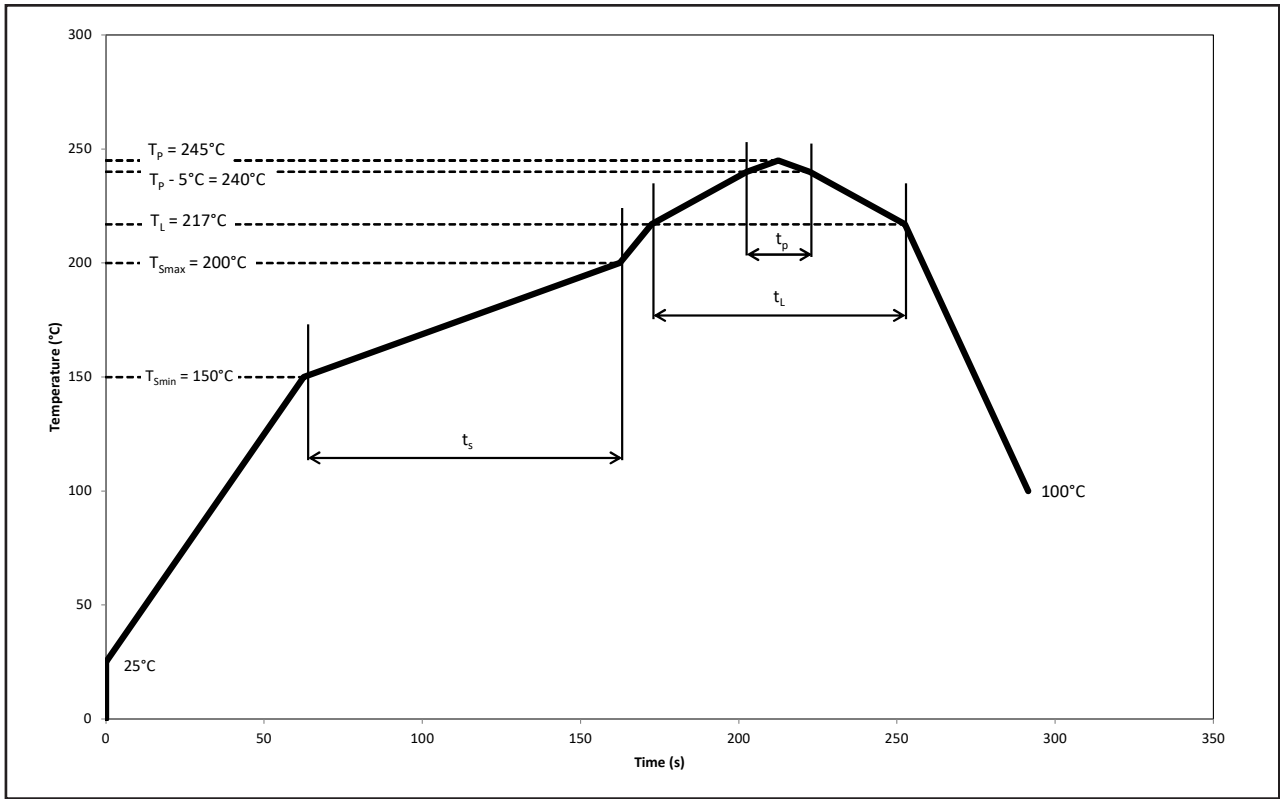

Profile Feature	Symbol	Pb-Free Assembly			Unit
		Min.	Recommended	Max.	
Ramp-up rate to preheat 25°C to $T_{smin}$	-	-	2	3	°C/s
Time $t_s$ $T_{smin}$ to $T_{smax}$	$t_s$	60	100	120	s
Ramp-up rate to peak $T_L$ to $T_p$	-	-	2	3	°C/s
Liquidous temperature	$T_L$	-	217	-	°C
Time above liquidous temperature	$t_L$	60	80	150	s
Peak temperature	$T_p$	-	245	260	°C
Time within 5°C of the specified peak temperature $T_p - 5^\circ\text{C}$	$t_p$	10	20	30	s
Ramp-down rate $T_p$ to 100°C	-	-	3	6	°C/s
Time 25°C to $T_p$	-	-	-	480	s

## Appendix

### 1) **Brightness:**

- 1.1 Luminous intensity is measured at current pulse 25 ms(typ) with an internal reproducibility of  $\pm 8\%$  and an expanded uncertainty of  $\pm 11\%$  (according to GUM with a coverage factor of  $k=3$ ).
- 1.2 Luminous flux is measured at current pulse 25 ms(typ) with an internal reproducibility of  $\pm 8\%$  and an expanded uncertainty of  $\pm 11\%$  (according to GUM with a coverage factor of  $k=3$ ).
- 1.3 Radiant intensity is measured at current pulse 25 ms(typ) with an internal reproducibility of  $\pm 8\%$  and an expanded uncertainty of  $\pm 11\%$  (according to GUM with a coverage factor of  $k=3$ ).
- 1.4 Radiant flux is measured at current pulse 25 ms(typ) with an internal reproducibility of  $\pm 8\%$  and an expanded uncertainty of  $\pm 11\%$  (according to GUM with a coverage factor of  $k=3$ ).

### 2) **Color:**

- 2.1 Chromaticity coordinate groups are measured at current pulse 25 ms(typ) with an internal reproducibility of  $\pm 0.005$  and an expanded uncertainty of  $\pm 0.01$  (accordingly to GUM with a coverage factor of  $k=3$ ).
- 2.2 Dominant wavelength is measured at current pulse 25 ms(typ) with an internal reproducibility of  $\pm 0.5\text{nm}$  and an expanded uncertainty of  $\pm 1\text{nm}$  (accordingly to GUM with a coverage factor of  $k=3$ ).

### 3) **Voltage:**

- 3.1 Forward Voltage,  $V_f$  is measured when a current pulse of 8 ms(typ) with an internal reproducibility of  $\pm 0.05\text{V}$  and an expanded uncertainty of  $\pm 0.1\text{V}$  (accordingly to GUM with a coverage factor of  $k=3$ ).

### 4) **Typical Values:**

- 4.1 Due to the specific conditions of semiconductor devices' manufacturing processes, the provided typical data and calculated correlations of technical parameters should only be considered as statistical values. It is important to note that the actual parameters of individual devices may deviate from these typical data, calculated correlations or the typical characteristic line. Dominant reserves the right to update this typical data without prior notice, particularly in response to technical enhancements.

### 5) **Tolerance of Measure**

- 5.1 Unless otherwise noted in drawing, tolerances are specified with  $\pm 0.1$  and dimension are specified in mm.

### 6) **Corrosion Robustness:**

- 6.1 Test conditions:  $40\text{ }^\circ\text{C} / 90\% \text{ rh} / 15 \text{ ppm H}_2\text{S} / 336 \text{ h}$ .  
= Stricter than IEC 60068-2-43 ( $\text{H}_2\text{S}$ ) [ $25\text{ }^\circ\text{C} / 75\% \text{ rh} / 10 \text{ ppm H}_2\text{S} / 21 \text{ days}$ ].

### 7) **Reverse Voltage:**

- 7.1 Not designed for reverse operation. Continuous reverse voltage can cause migration and LED damage.

### 8)

- 8.1 Package edge may have plastic burr or protrusion no bigger than 0.05mm.

**Revision History**

<b>Page</b>	<b>Subjects</b>	<b>Date of Modification</b>
-	Initial Release	20 Aug 2020
8, 9, 11, 12	Update Package Outline Update Solder Pad Drawing Update Standard Packing from 2000pcs to 4000pcs	16 Oct 2020
1, 2, 4,	Update Product Photo Not for New Design : SVS-SHG-M3P2-3, SVS-SHG-NP3-2, SVA-SHG-PQ3-4, SVA-SHG-QR3-2, SVY-SHG-P3R2-4, SVY-SHG-PQ3-3, SVY-SHG-N3Q2-2 Add New Partno : SVS-SHG-NP3-3, SVS-SHG-N3Q2-2,SVA-SHG-P3R2-4, SVA-SHG-Q3S2-2,SVY-SHG-QR3-4, SVY-SHG-P3R2-3,SVY-SHG-PQ3-2 Update Luminous Flux Group	10 May 2021
2, 6	Update Peak Pulse Current Update Graph: Allowable Forward Current Vs Duty Ratio	21 Jul 2021
2	Add New Partno: SVS-SHG-NP9-3, SVS-SHG-N9Q8-2, SVA-SHG-P9R8-4, SVA-SHG-Q9S8-2, SVY-SHG-Q9S8-4, SVY-SHG-QR9-3, SVY-SHG-P9R8-2	19 Apr 2022
9	Add Polarity in Package Outline	11 Aug 2022
4, 7, 8	Update Electrical Characteristics Update Graph: Forward Current Vs Forward Voltage Update Graph: Forward Voltage Vs Junction Temperature	24 Feb 2023
12. 13	Update Optional Packing	01 Nov 2024
1, 9	Update Product Photo Update Package Outline	11 Feb 2026

**NOTE**

All the information contained in this document is considered to be reliable at the time of publishing. However, DOMINANT Opto Technologies does not assume any liability arising out of the application or use of any product described herein.

DOMINANT Opto Technologies reserves the right to make changes to any products in order to improve reliability, function or design.

DOMINANT Opto Technologies products are not authorized for use as critical components in life support devices or systems without the express written approval from the Managing Director of DOMINANT Opto Technologies.

Dispose of product is in accordance with local, regional, national and international regulations.

## About Us

DOMINANT Opto Technologies is a dynamic company that is amongst the world's leading automotive LED manufacturers. With an extensive industry experience and relentless pursuit of innovation, DOMINANT's state-of-art manufacturing and development capabilities have become a trusted and reliable brand across the globe. More information about DOMINANT Opto Technologies, an IATF 16949 and ISO 14001 certified company, can be found under <http://www.dominant-semi.com>.

**Please contact us for more information:**

DOMINANT Opto Technologies Sdn. Bhd  
Lot 6, Batu Berendam, FTZ Phase III, 75350 Melaka, Malaysia.  
Tel: +606 283 3566 Fax: +606 283 0566  
E-mail: [sales@dominant-semi.com](mailto:sales@dominant-semi.com)

---