

SpicePlus

Like spice, its diminutive size is a stark contrast to its standout performance in terms of brightness, durability and reliability. Despite being the smallest in size yet the SpicePlus packs a powerful performance and is a highly reliable design device.



Features:

- > Super high brightness surface mount LED automotive exterior applications.
- > 120° viewing angle.
- > Compact package outline (LxW) of 2.5 x 2.0mm.
- > Ultra low height profile - 0.7mm.
- > Low thermal resistance.
- > Superior corrosion robustness.
- > Compatible to IR reflow soldering.
- > Compliance to automotive standard; AEC-Q102.
- > Environmental friendly; RoHS compliance.



Applications:

- > Automotive: Exterior application: eg: Turn Signal.

Optical Characteristics at Tj=25°C

Part Number	Color	Viewing Angle°	Luminous Flux @ 80mA (lm) <i>Appx. 1.2</i>		
			Min.	Typ.	Max.
SVZY-FZHG-M3P2-1	InGaN Yellow	120	15.8	22.0	26.8

Electrical Characteristics at Tj=25°C

Part Number	Vf @ If = 80mA <i>Appx. 3.1</i>		
	Min. (V)	Typ. (V)	Max. (V)
SVZY-FZHG	2.6	2.9	3.2

Absolute Maximum Ratings

	Maximum Value	Unit
DC forward current	150	mA
Peak pulse current; (Ts = 55°C, tp ≤ 100µs, Duty cycle = 0.03)	600	mA
Reverse voltage	Not designed for reverse bias	V
ESD threshold (HBM)	8	KV
LED junction temperature	150	°C
Operating temperature	-40 ... +125	°C
Storage temperature	-40 ... +125	°C
Thermal resistance (Rated current = 80mA, Ts = 25 °C)		
- Real Thermal Resistance		
Junction / solder point, R _{th JS real} (typ =16)	26	K/W
- Electrical Thermal Resistance		
Junction / solder point, R _{th JS el} (typ = 12)	20	K/W

SVZY, Color Grouping *Appx. 2.1*

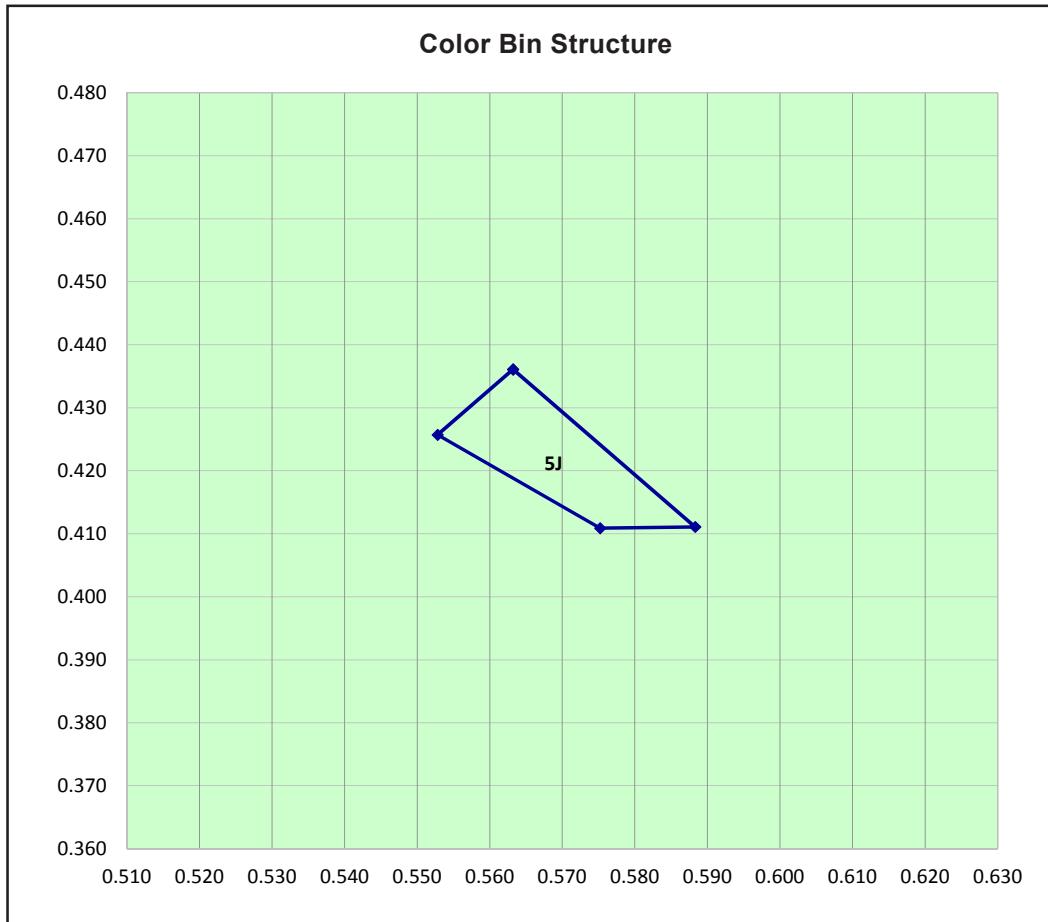

Bin		1	2	3	4
5J	Cx	0.5632	0.5528	0.5752	0.5883
	Cy	0.4361	0.4257	0.4109	0.4111

InGaN wavelength is very sensitive to drive current. Operating at lower current is not recommended and may yield unpredictable performance. Current pulsing should be used for dimming purposes.

Luminous Flux Group at Tj=25°C

Brightness Group	Luminous Flux <small>Appx. 1.2</small> (lm)
M3	15.8 ... 18.1
N2	18.1 ... 20.6
N3	20.6 ... 23.5
P2	23.5 ... 26.8

Vf Bining (Optional)

Vf Bin @ 80mA	Forward Voltage (V) <small>Appx. 4.1</small>
VH7	2.60 ... 2.80
VH8	2.80 ... 3.00
VH9	3.00 ... 3.20

Please consult sales and marketing for special part number to incorporate Vf binning.

Relative Luminous Flux Vs Forward Current *Appx. 4.1*

$\Phi_V/\Phi_V(80\text{mA}) = f(I_F); T_j = 25^\circ\text{C}$

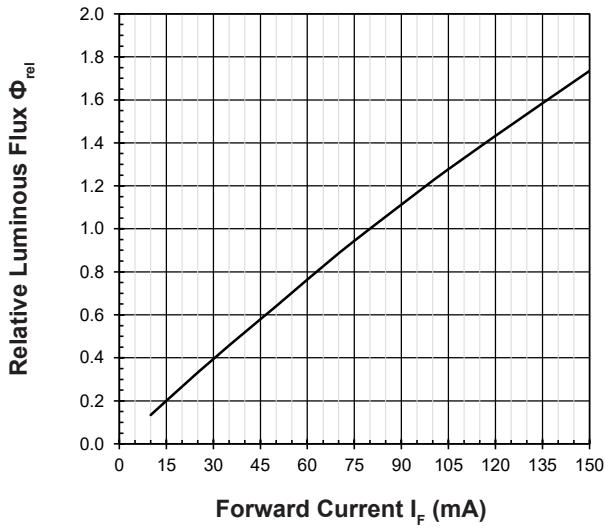

Forward Current Vs Forward Voltage *Appx. 4.1*

$I_F = f(V_F); T_j = 25^\circ\text{C}$

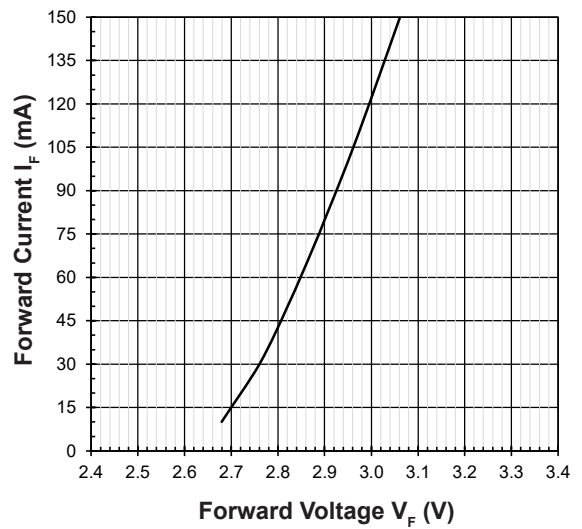

Maximum Current Vs Temperature

$I_F = f(T)$

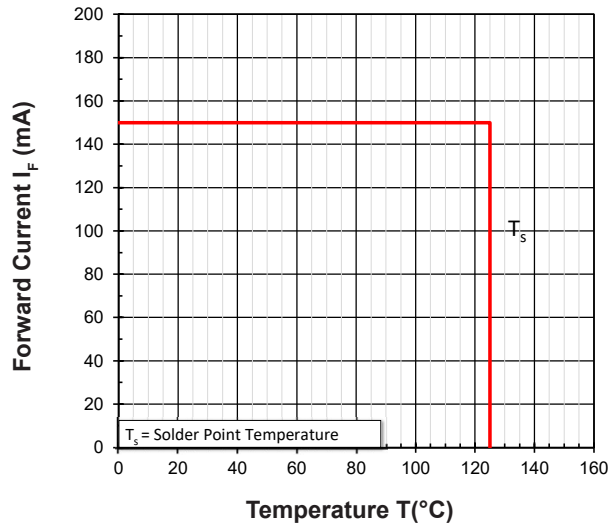

Relative Spectral Emission *Appx. 4.1*

$\Phi_{rel} = f(\lambda); T_j = 25^\circ\text{C}; I_F = 80\text{mA}$

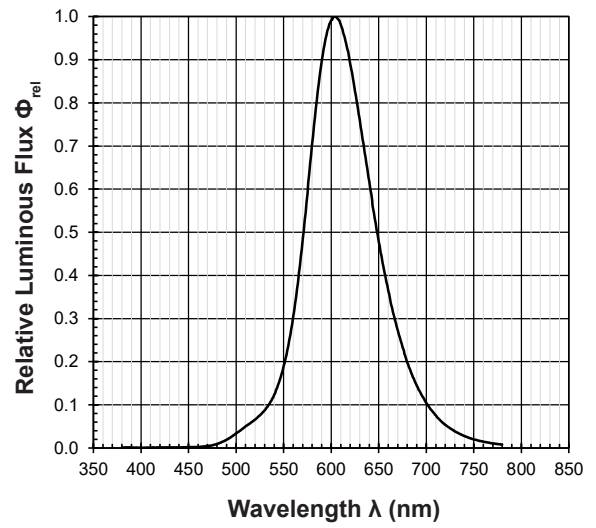

Chromaticity Coordinate Shift Vs Forward Current *Appx. 4.1*

$\Delta Cx, \Delta Cy = f(I_F); T_j = 25^\circ\text{C}$

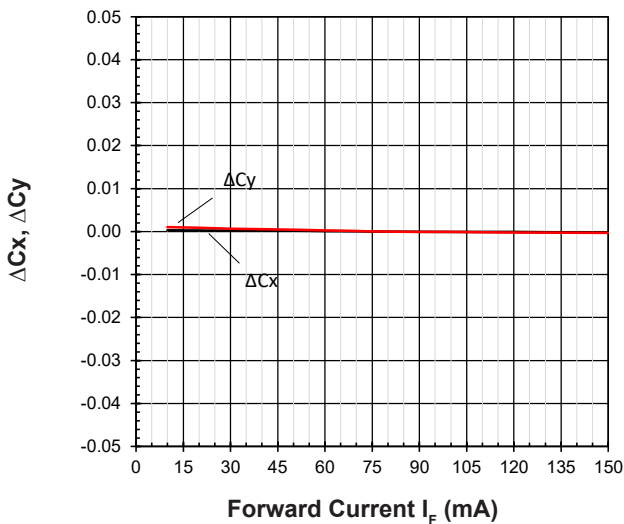

Allowable Forward Current Vs Duty Ratio

$(T_s = 55^\circ\text{C}; t_p \leq 100\mu\text{s})$

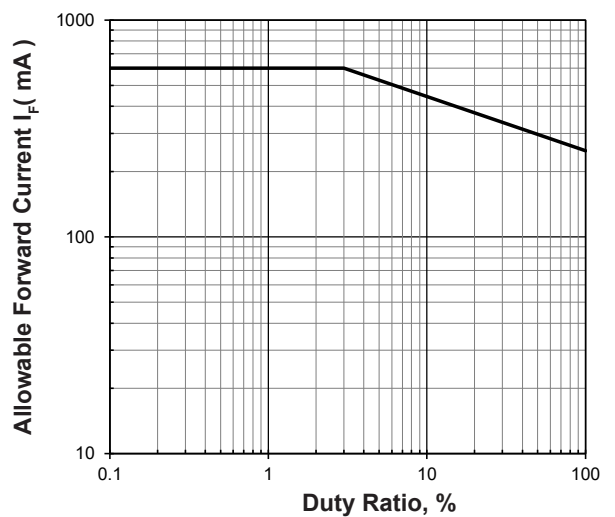

Radiation Pattern *Appx. 4.1*

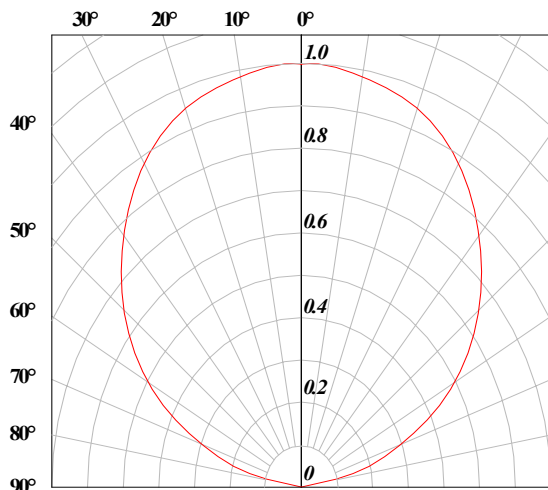

Forward Voltage Vs Junction Temperature *Appx. 4.1*

$$\Delta V_F = V_F - V_F(25^\circ\text{C}) = f(T_j); I_F = 80\text{mA}$$

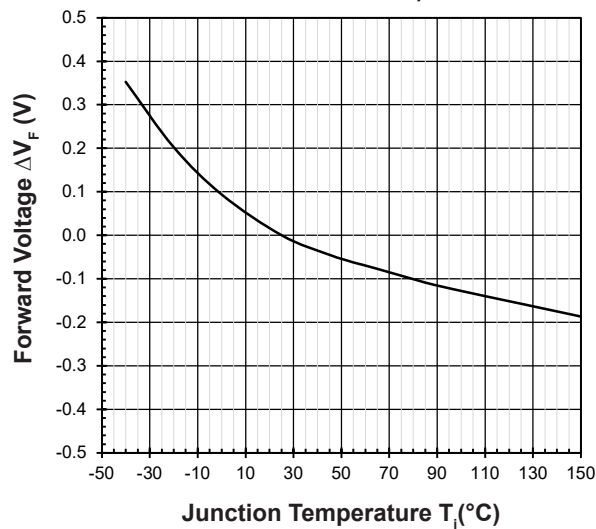

Relative Luminous Flux Vs Junction Temperature *Appx. 4.1*

$$\Phi_V/\Phi_V(25^\circ\text{C}) = f(T_j); I_F = 80\text{mA}$$

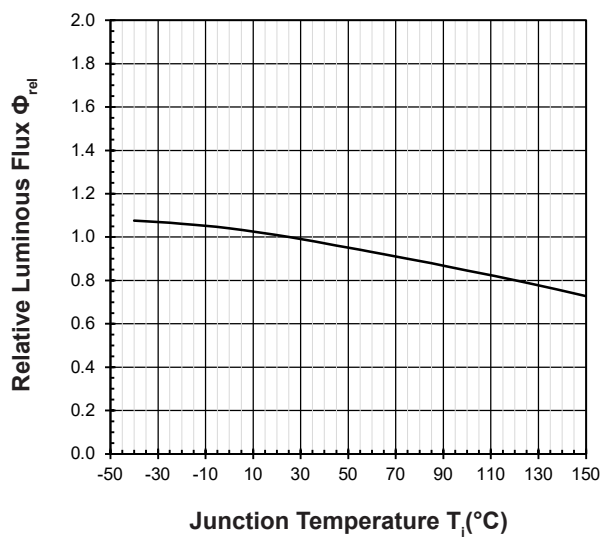

Chromaticity Coordinate Shift Vs Junction Temperature *Appx. 4.1*

$$\Delta C_x, \Delta C_y = f(T_j); I_F = 80\text{mA}$$

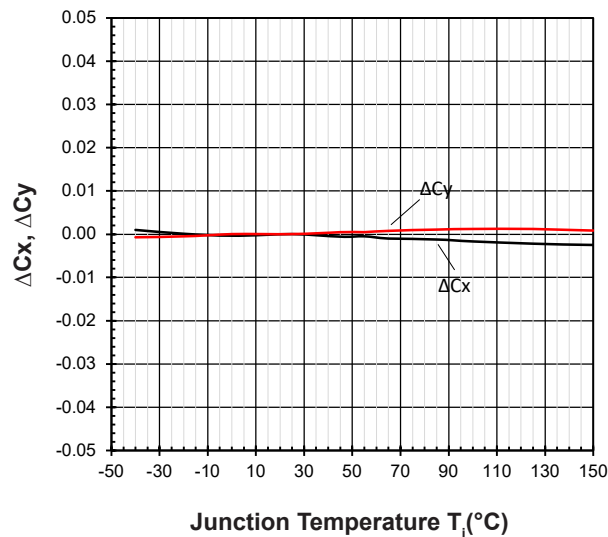

SpicePlus 2520 InGaN: SVZY-FZHG Package Outlines *Appx. 5.1*

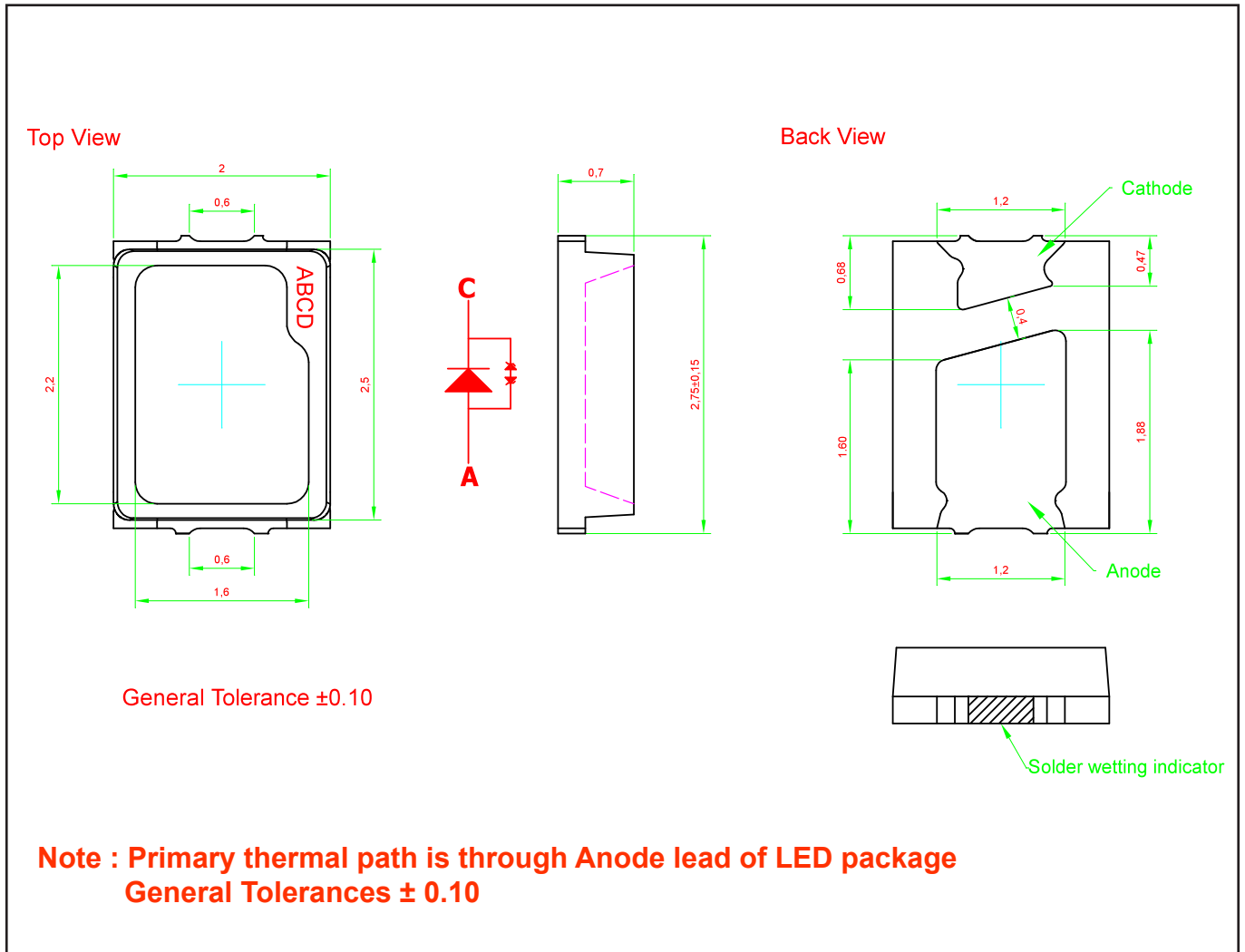

Material

Material	
Lead-frame	Cu Alloy With Au Plating
Package	High Temperature Resistant Plastic
Encapsulant	Silicone Resin
Soldering Leads	Sn Plating

Recommended Solder Pad *Appx. 5.1*

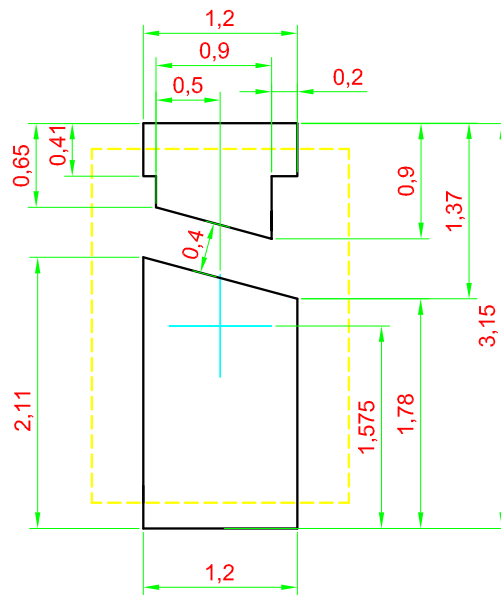

Taping and orientation *Appx. 5.1*

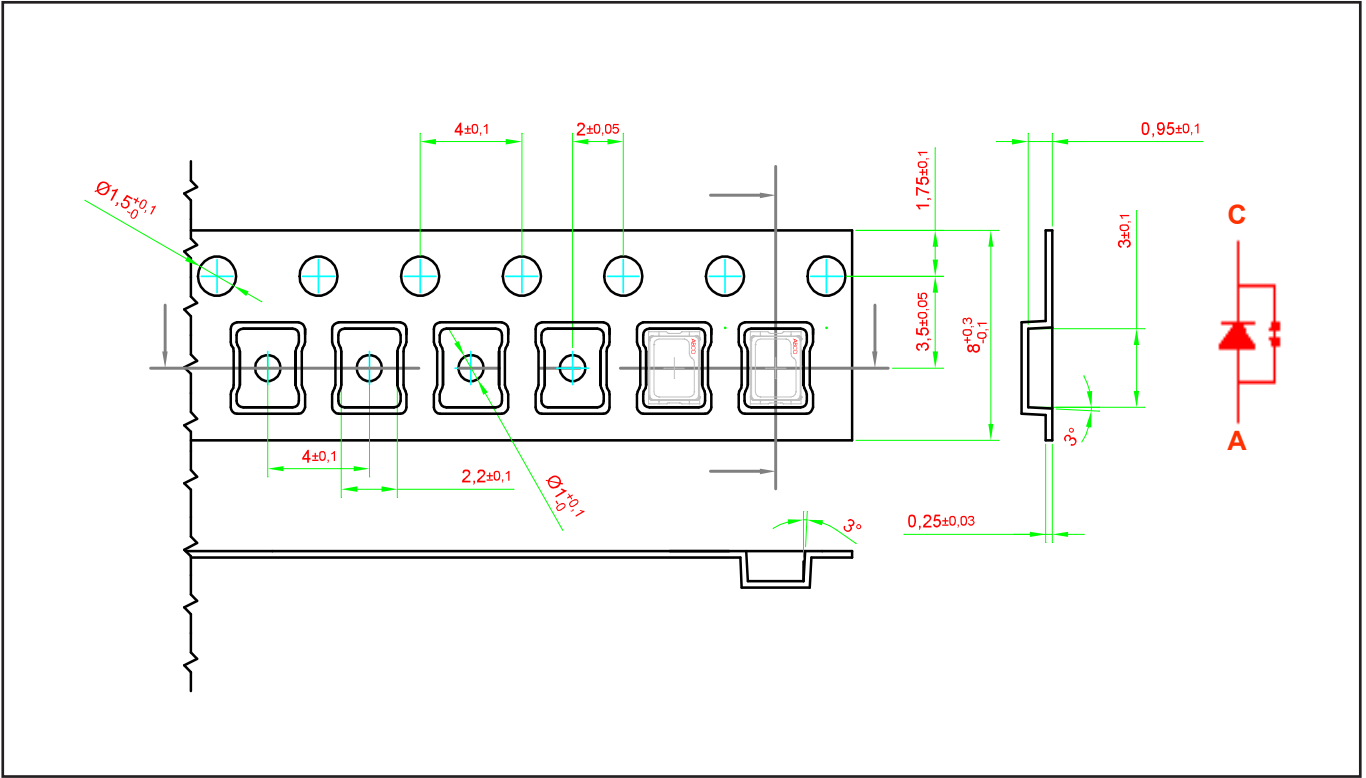

Packaging Specification

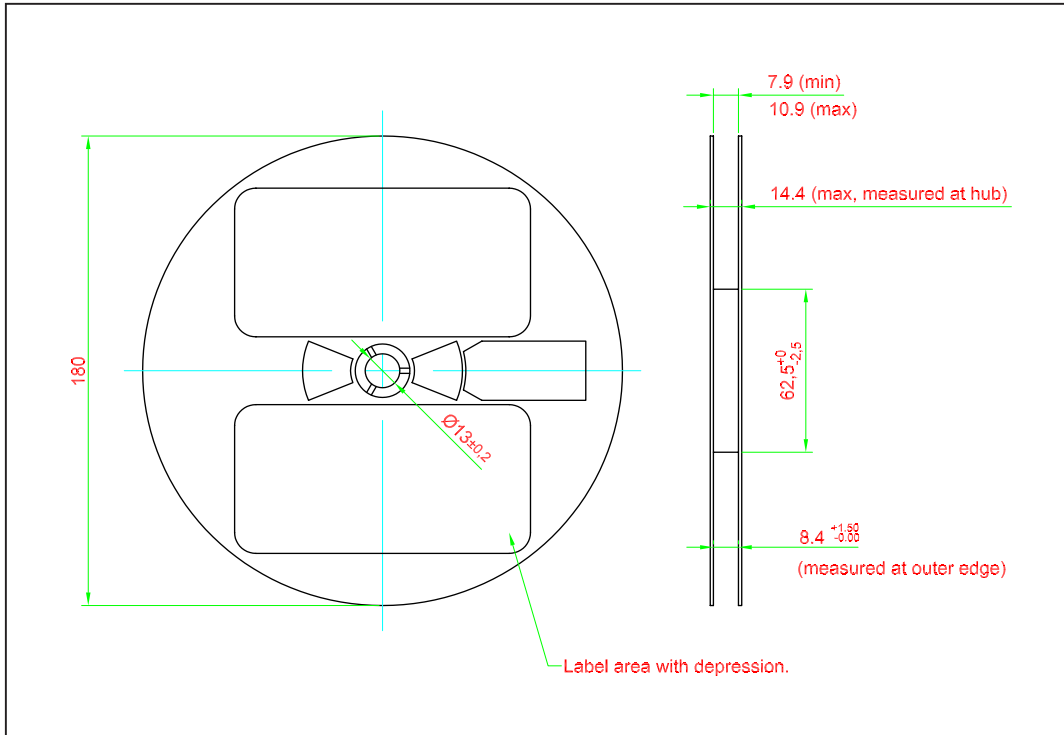

	Reel Diameter (mm)	Quantity (pcs)	*Ordering Number
Standard Packing	180	4000	SVZY-FZHG-xxx-x

Notes:

* For ordering purpose only. Please consult sales and marketing for details.

Packaging Specification

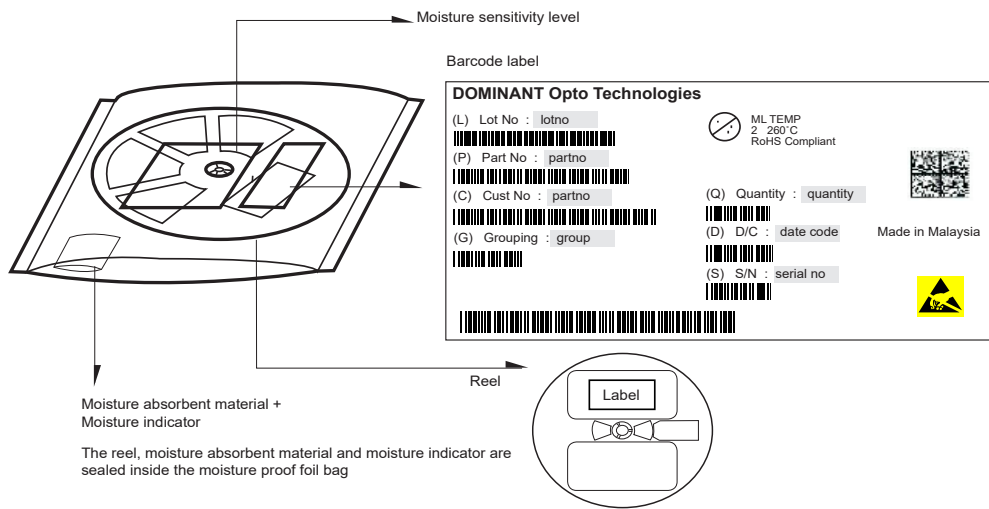

Quantity per bag (pcs)	Average 1pc SpicePlus 2520 (g)	1 completed bag (g)
4000	0.0089	150 ± 10

Recommended Pb-free Soldering Profile

Product complies to MSL Level 2 acc. to JEDEC J-STD-020E

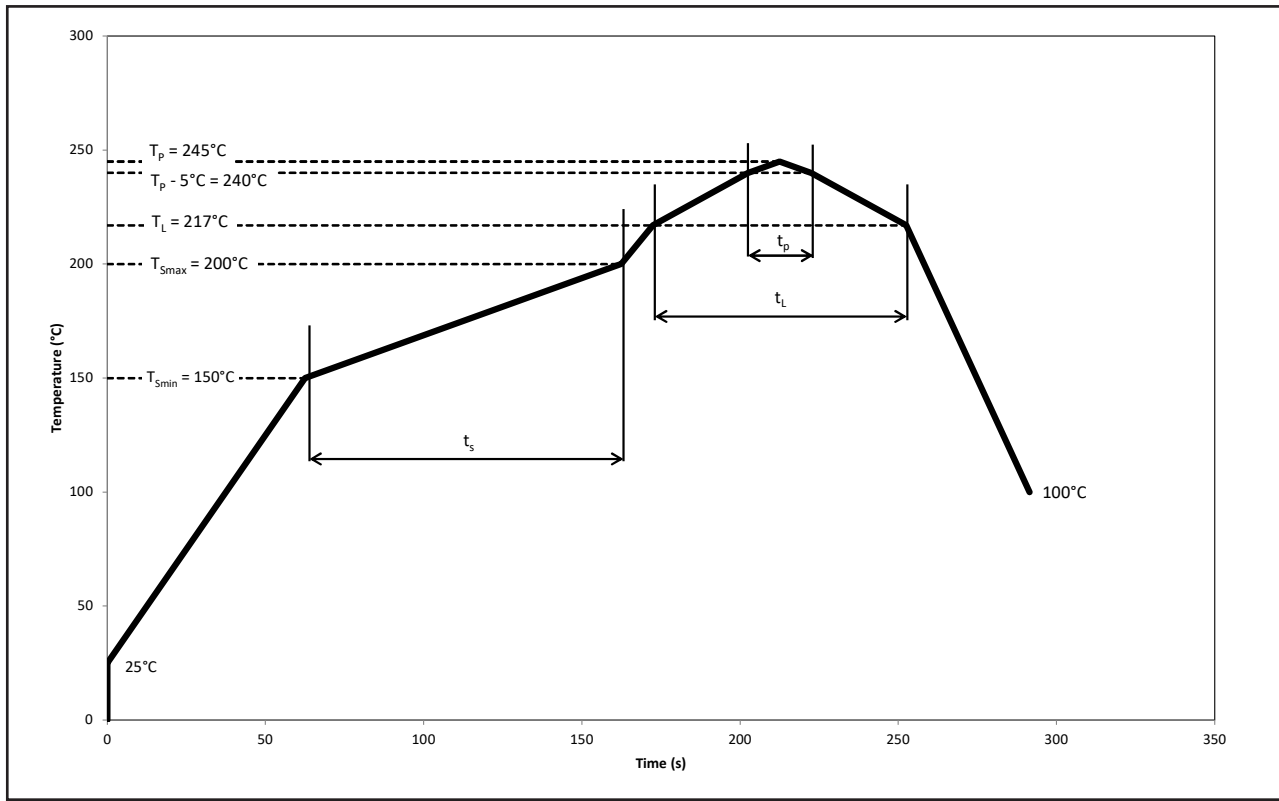

Profile Feature	Symbol	Pb-Free Assembly			Unit
		Min.	Recommended	Max.	
Ramp-up rate to preheat 25°C to T_{smin}	-	-	2	3	°C/s
Time t_s T_{smin} to T_{smax}	t_s	60	100	120	s
Ramp-up rate to peak T_L to T_p	-	-	2	3	°C/s
Liquidous temperature	T_L	-	217	-	°C
Time above liquidous temperature	t_L	60	80	150	s
Peak temperature	T_p	-	245	260	°C
Time within 5°C of the specified peak temperature $T_p - 5^\circ\text{C}$	t_p	10	20	30	s
Ramp-down rate T_p to 100°C	-	-	3	6	°C/s
Time 25°C to T_p	-	-	-	480	s

Appendix

1) **Brightness:**

- 1.1 Luminous intensity is measured at current pulse 25 ms(typ) with an internal reproducibility of $\pm 8\%$ and an expanded uncertainty of $\pm 11\%$ (according to GUM with a coverage factor of $k=3$).
- 1.2 Luminous flux is measured at current pulse 25 ms(typ) with an internal reproducibility of $\pm 8\%$ and an expanded uncertainty of $\pm 11\%$ (according to GUM with a coverage factor of $k=3$).
- 1.3 Radiant intensity is measured at current pulse 25 ms(typ) with an internal reproducibility of $\pm 8\%$ and an expanded uncertainty of $\pm 11\%$ (according to GUM with a coverage factor of $k=3$).
- 1.4 Radiant flux is measured at current pulse 25 ms(typ) with an internal reproducibility of $\pm 8\%$ and an expanded uncertainty of $\pm 11\%$ (according to GUM with a coverage factor of $k=3$).

2) **Color:**

- 2.1 Chromaticity coordinate groups are measured at current pulse 25 ms(typ) with an internal reproducibility of ± 0.005 and an expanded uncertainty of ± 0.01 (accordingly to GUM with a coverage factor of $k=3$).
- 2.2 Dominant wavelength is measured at current pulse 25 ms(typ) with an internal reproducibility of $\pm 0.5\text{nm}$ and an expanded uncertainty of $\pm 1\text{nm}$ (accordingly to GUM with a coverage factor of $k=3$).

3) **Voltage:**

- 3.1 Forward Voltage, V_f is measured when a current pulse of 8 ms(typ) with an internal reproducibility of $\pm 0.05\text{V}$ and an expanded uncertainty of $\pm 0.1\text{V}$ (accordingly to GUM with a coverage factor of $k=3$).

4) **Typical Values:**

- 4.1 Due to the specific conditions of semiconductor devices' manufacturing processes, the provided typical data and calculated correlations of technical parameters should only be considered as statistical values. It is important to note that the actual parameters of individual devices may deviate from these typical data, calculated correlations or the typical characteristic line. Dominant reserves the right to update this typical data without prior notice, particularly in response to technical enhancements.

5) **Tolerance of Measure**

- 5.1 Unless otherwise noted in drawing, tolerances are specified with ± 0.1 and dimension are specific in mm.

6) **Corrosion Robustness:**

- 6.1 Test conditions: $40\text{ }^\circ\text{C} / 90\% \text{ rh} / 15 \text{ ppm H}_2\text{S} / 336 \text{ h}$.
= Stricter than IEC 60068-2-43 (H_2S) [$25\text{ }^\circ\text{C} / 75\% \text{ rh} / 10 \text{ ppm H}_2\text{S} / 21 \text{ days}$].

Revision History

Page	Subjects	Date of Modification
-	Initial Release	22 Jul 2024
1, 7	Update Product Photo Update Package Outline	11 Feb 2026

NOTE

All the information contained in this document is considered to be reliable at the time of publishing. However, DOMINANT Opto Technologies does not assume any liability arising out of the application or use of any product described herein.

DOMINANT Opto Technologies reserves the right to make changes to any products in order to improve reliability, function or design.

DOMINANT Opto Technologies products are not authorized for use as critical components in life support devices or systems without the express written approval from the Managing Director of DOMINANT Opto Technologies.

Dispose of product is in accordance with local, regional, national and international regulations.

About Us

DOMINANT Opto Technologies is a dynamic company that is amongst the world's leading automotive LED manufacturers. With an extensive industry experience and relentless pursuit of innovation, DOMINANT's state-of-art manufacturing and development capabilities have become a trusted and reliable brand across the globe. More information about DOMINANT Opto Technologies, an IATF 16949 and ISO 14001 certified company, can be found under <http://www.dominant-semi.com>.

Please contact us for more information:

DOMINANT Opto Technologies Sdn. Bhd
Lot 6, Batu Berendam, FTZ Phase III, 75350 Melaka, Malaysia.
Tel: +606 283 3566 Fax: +606 283 0566
E-mail: sales@dominant-semi.com