

### **DomiLED**

Synonymous with function and performance, the DomiLED series is perfectly suited for a variety of cross-industrial applications due to its small package outline, durability and superior brightness.



### **Features:**

- > High brightness surface mount LED.
- > Designed for sideway illumination.
- > 120° viewing angle.
- > Small package outline.
- > Qualified according to JEDEC moisture sensitivity Level 2.
- > Compatible to IR reflow soldering.
- > Environmental friendly; RoHS compliance.
- > Compliance to automotive standard; AEC-Q101.
- > Passed Corrosion Resistant Test.



### **Applications:**

- > Automotive: interior applications, eg: switches, telematics, climate control system, dashboard, etc.
- > Consumer Appliances: LCD illumination as in PDAs, LCD TV.
- > Display: full color display video notice board.
- > Industry: white goods (eg: Oven, microwave, etc.).



**Optical Characteristics at Tj=25°C**

| Part Number          | Viewing Angle° | Luminous Intensity @ 20mA IV (mcd) <i>Appx. 1.1</i> |        |        |
|----------------------|----------------|---|--------|--------|
|                      |                | Min.  | Typ.   | Max.   |
| ● DSZB-LSG-V2W-1     | 120            | 900.0   | 1400.0 | 1800.0 |
| ● DSZB-LSG-WX1-1     | 120            | 1125.0  | 1800.0 | 2240.0 |
| ● Not for new design |                |   |        |        |

**Electrical Characteristics at Tj=25°C**

| Part Number | Vf @ If = 20mA <i>Appx. 3.1</i> |          |          | Vr @ Ir = 10uA |
|-------------|---------------------------------|----------|----------|----------------|
|             | Min. (V)                        | Typ. (V) | Max. (V) | Min. (V)       |
| DSZB-LSG    | 2.8                             | 3.1      | 3.5      | 5.0            |

**Absolute Maximum Ratings**

|   | Maximum Value | Unit |
|---|---------------|------|
| DC forward current  | 20            | mA   |
| Peak pulse current; (tp ≤ 10µs, Duty cycle = 0.005)         | 100           | mA   |
| Reverse voltage; Ir (max) = 10uA <i>Appx. 6.1</i>           | 5             | V    |
| ESD threshold (HBM)   | 2000          | V    |
| LED junction temperature                                    | 125           | °C   |
| Operating temperature                                       | -40 ... +100  | °C   |
| Storage temperature   | -40 ... +100  | °C   |
| Power dissipation (at room temperature)                     | 80            | mW   |
| Thermal resistance (Rated current = 20mA, Ts = 25 °C)       |               |      |
| - Junction / ambient, Rth JA                                | 460           | K/W  |
| - Junction / solder point, Rth JS                           | 240           | K/W  |
| (Mounting on FR4 PCB, pad size ≥ 5 mm <sup>2</sup> per pad) |               |      |

**Color Grouping** *Appx. 2.1*

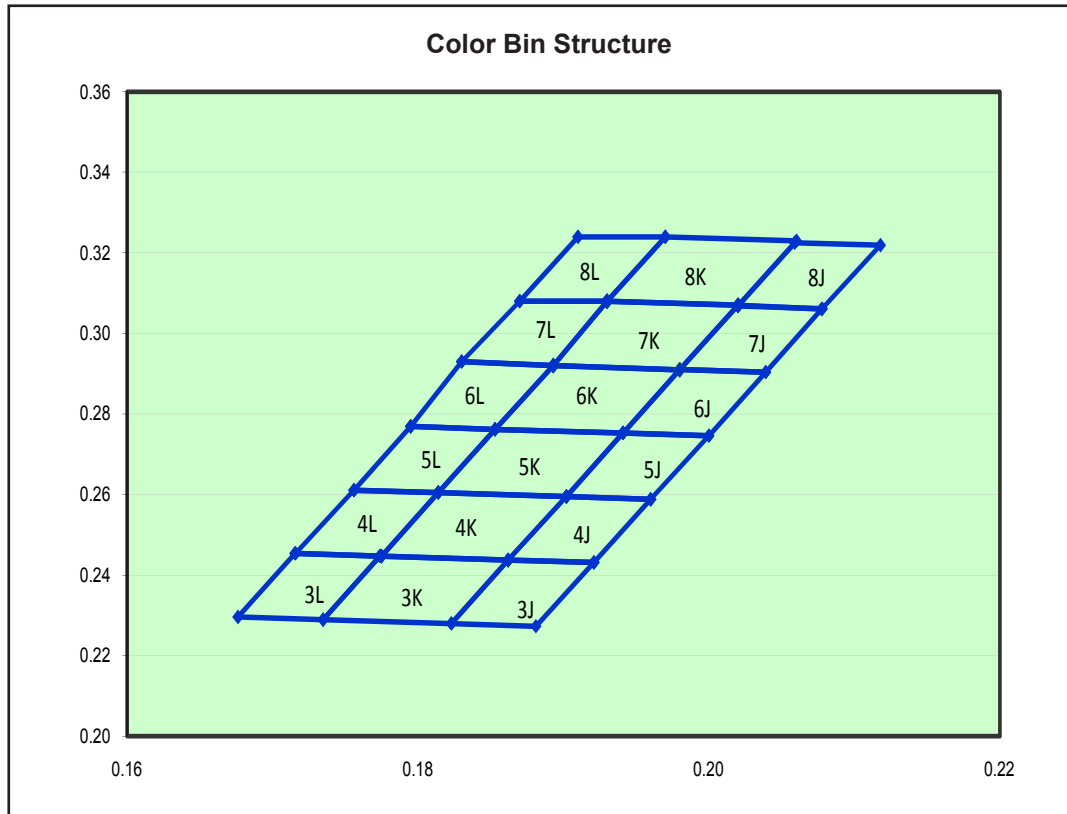

| Bin |    | 1      | 2      | 3      | 4      |
|-----|----|--------|--------|--------|--------|
| 3J  | Cx | 0.1862 | 0.1823 | 0.1881 | 0.1921 |
|     | Cy | 0.2437 | 0.2280 | 0.2273 | 0.2431 |
| 3K  | Cx | 0.1774 | 0.1735 | 0.1823 | 0.1862 |
|     | Cy | 0.2447 | 0.2289 | 0.2280 | 0.2437 |
| 3L  | Cx | 0.1716 | 0.1676 | 0.1735 | 0.1774 |
|     | Cy | 0.2454 | 0.2296 | 0.2289 | 0.2447 |
| 4J  | Cx | 0.1902 | 0.1862 | 0.1921 | 0.1960 |
|     | Cy | 0.2595 | 0.2437 | 0.2431 | 0.2588 |
| 4K  | Cx | 0.1814 | 0.1775 | 0.1862 | 0.1902 |
|     | Cy | 0.2605 | 0.2447 | 0.2437 | 0.2595 |
| 4L  | Cx | 0.1756 | 0.1716 | 0.1775 | 0.1814 |
|     | Cy | 0.2611 | 0.2454 | 0.2447 | 0.2605 |
| 5J  | Cx | 0.1941 | 0.1902 | 0.1960 | 0.2000 |
|     | Cy | 0.2753 | 0.2595 | 0.2588 | 0.2746 |
| 5K  | Cx | 0.1853 | 0.1814 | 0.1902 | 0.1941 |
|     | Cy | 0.2762 | 0.2605 | 0.2595 | 0.2753 |
| 5L  | Cx | 0.1795 | 0.1756 | 0.1814 | 0.1853 |
|     | Cy | 0.2769 | 0.2611 | 0.2605 | 0.2762 |
| 6J  | Cx | 0.1980 | 0.1941 | 0.2000 | 0.2039 |
|     | Cy | 0.2910 | 0.2753 | 0.2746 | 0.2904 |
| 6K  | Cx | 0.1893 | 0.1853 | 0.1941 | 0.1980 |
|     | Cy | 0.2920 | 0.2762 | 0.2753 | 0.2910 |
| 6L  | Cx | 0.1830 | 0.1795 | 0.1853 | 0.1893 |
|     | Cy | 0.2930 | 0.2769 | 0.2762 | 0.2920 |

| <b>Bin</b> |    | <b>1</b> | <b>2</b> | <b>3</b> | <b>4</b> |
|------------|----|----------|----------|----------|----------|
| 7J         | Cx | 0.2020   | 0.1980   | 0.2039   | 0.2078   |
|            | Cy | 0.3070   | 0.2910   | 0.2904   | 0.3060   |
| 7K         | Cx | 0.1930   | 0.1893   | 0.1980   | 0.2020   |
|            | Cy | 0.3080   | 0.2920   | 0.2910   | 0.3070   |
| 7L         | Cx | 0.1870   | 0.1830   | 0.1893   | 0.1930   |
|            | Cy | 0.3080   | 0.2930   | 0.2920   | 0.3080   |
| 8J         | Cx | 0.2059   | 0.2020   | 0.2078   | 0.2118   |
|            | Cy | 0.3225   | 0.3068   | 0.3061   | 0.3219   |
| 8K         | Cx | 0.1970   | 0.1930   | 0.2020   | 0.2060   |
|            | Cy | 0.3240   | 0.3080   | 0.3070   | 0.3230   |
| 8L         | Cx | 0.1910   | 0.1870   | 0.1930   | 0.1970   |
|            | Cy | 0.3240   | 0.3080   | 0.3080   | 0.3240   |

InGaN wavelength is very sensitive to drive current. Operating at lower current is not recommended and may yield unpredictable performance. Current pulsing should be used for dimming purposes.

**Luminous Intensity Group at Tj=25°C**

| Brightness Group | Luminous Intensity <small>Appx. 1.1</small><br>IV (mcd) |
|------------------|---|
| V2               | 900.0 ... 1125.0  |
| W1               | 1125.0 ... 1400.0                                       |
| W2               | 1400.0 ... 1800.0                                       |
| X1               | 1800.0 ... 2240.0                                       |

**Relative Luminous Intensity Vs Forward Current** *Appx. 4.1*

$I_v/I_v(20mA) = f(I_F); T_j = 25^\circ C$

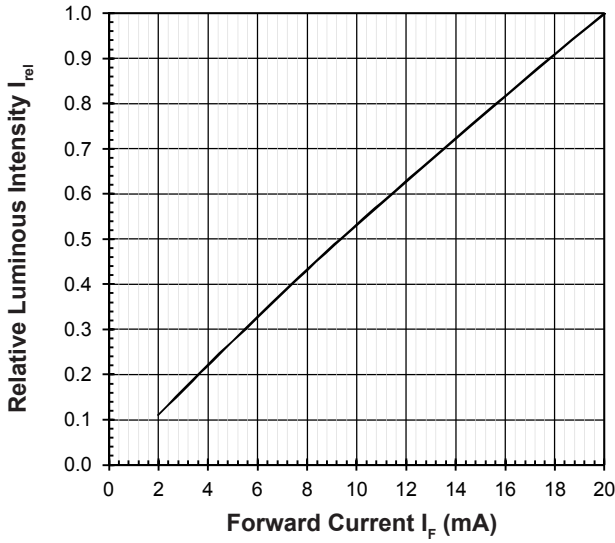

**Forward Current Vs Forward Voltage** *Appx. 4.1*

$I_F = f(V_F); T_j = 25^\circ C$

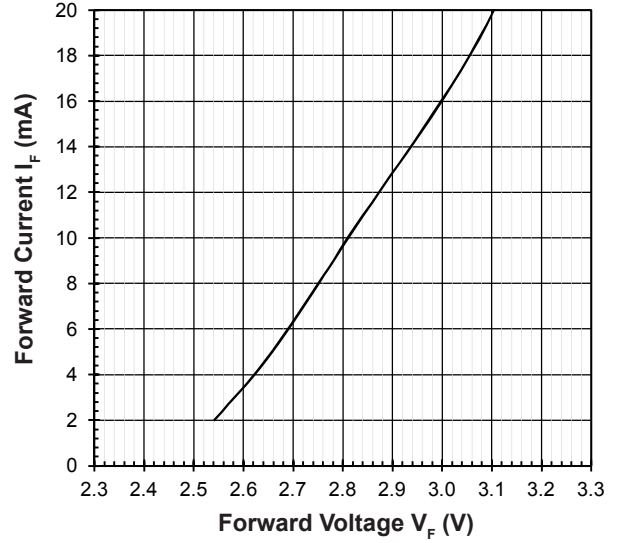

**Maximum Current Vs Temperature**

$I_F = f(T)$

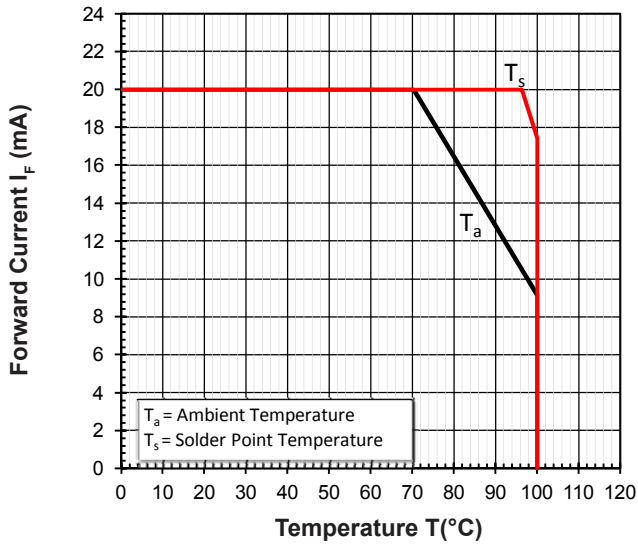

**Relative Spectral Emission** *Appx. 4.1*

$I_{rel} = f(\lambda); T_j = 25^\circ C; I_F = 20mA$

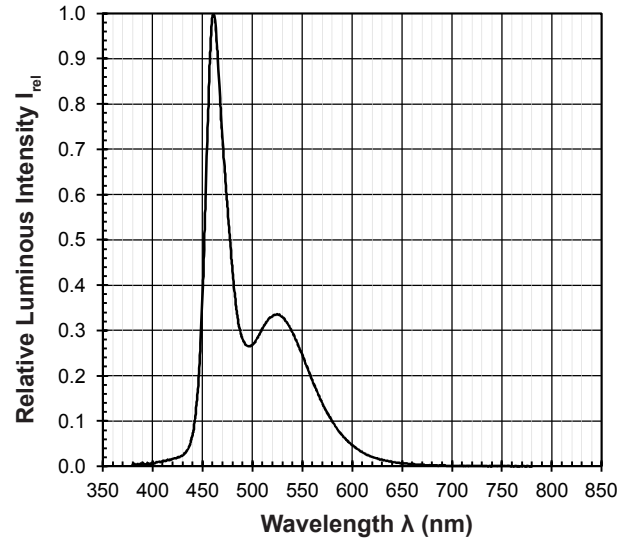

**Chromaticity Coordinate Shift Vs Forward Current** *Appx. 4.1*

$\Delta Cx, \Delta Cy = f(I_F); T_j = 25^\circ C$

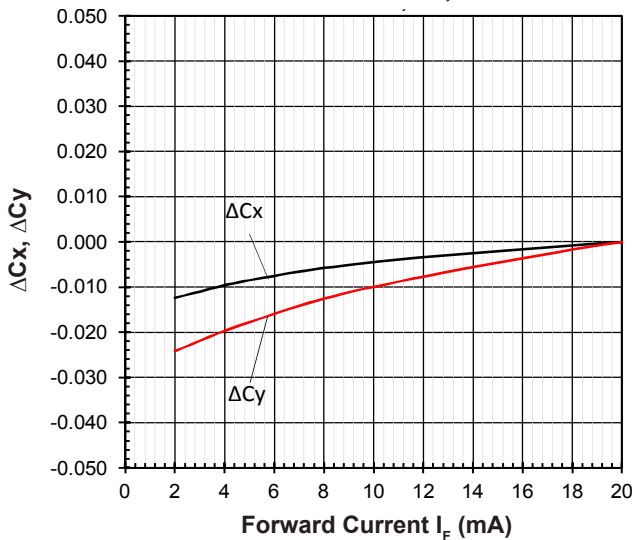

**Allowable Forward Current Vs Duty Ratio**

$(T_j = 25^\circ C; t_p \leq 10\mu s)$

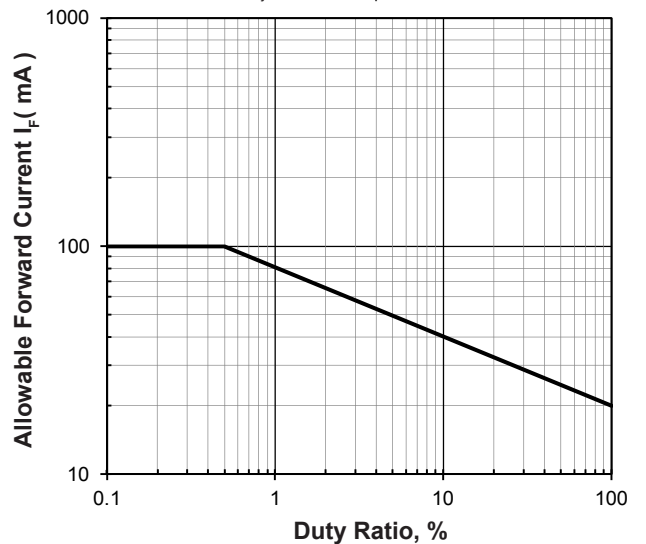

**Radiation Pattern** *Appx. 4.1*

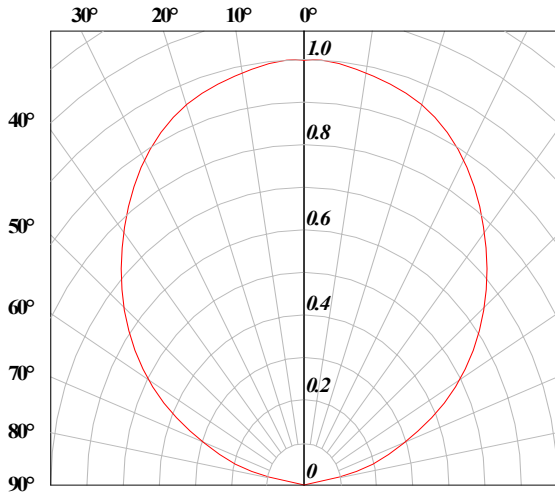

**Forward Voltage Vs Junction Temperature** *Appx. 4.1*

$$\Delta V_F = V_F - V_F(25^\circ\text{C}) = f(T_j); I_F = 20\text{mA}$$

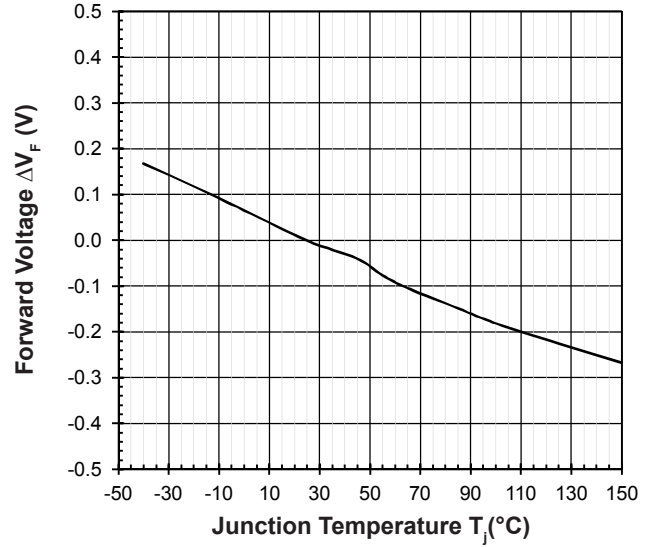

**Relative Luminous Intensity Vs Junction Temperature** *Appx. 4.1*

$$I_V/I_V(25^\circ\text{C}) = f(T_j); I_F = 20\text{mA}$$

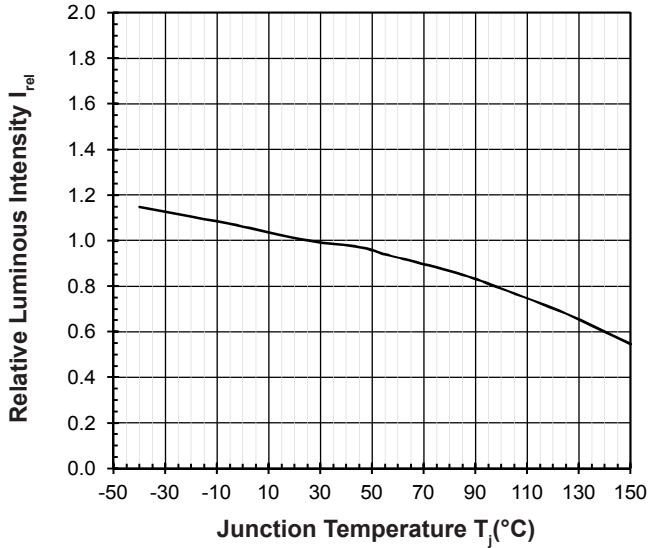

**Chromaticity Coordinate Shift Vs Junction Temperature** *Appx. 4.1*

$$\Delta Cx, \Delta Cy = f(T_j); I_F = 20\text{mA}$$

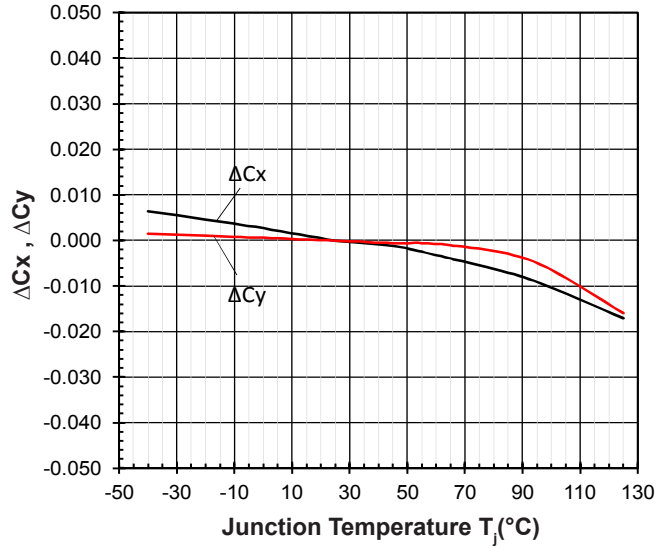

**Right Angle DomiLED • InGaN : DSZB-LSG Package Outlines** *Appx. 5.1*

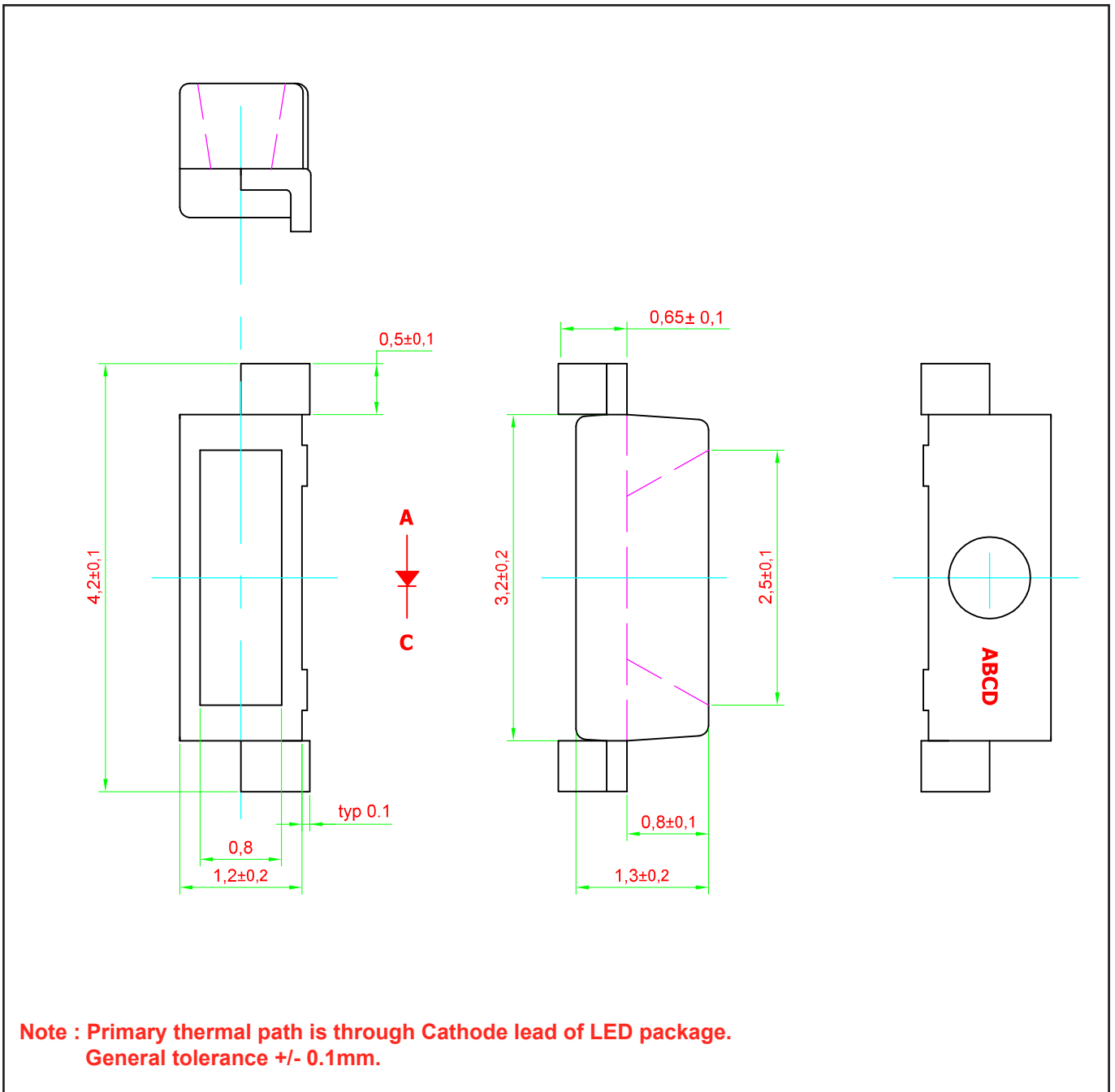

**Material**

| Material        |                                    |
|-----------------|------------------------------------|
| Lead-frame      | Cu Alloy With Ag Plating           |
| Package         | High Temperature Resistant Plastic |
| Encapsulant     | Silicone Resin                     |
| Soldering Leads | Sn Plating                         |

**Recommended Solder Pad** *Appx. 5.1*

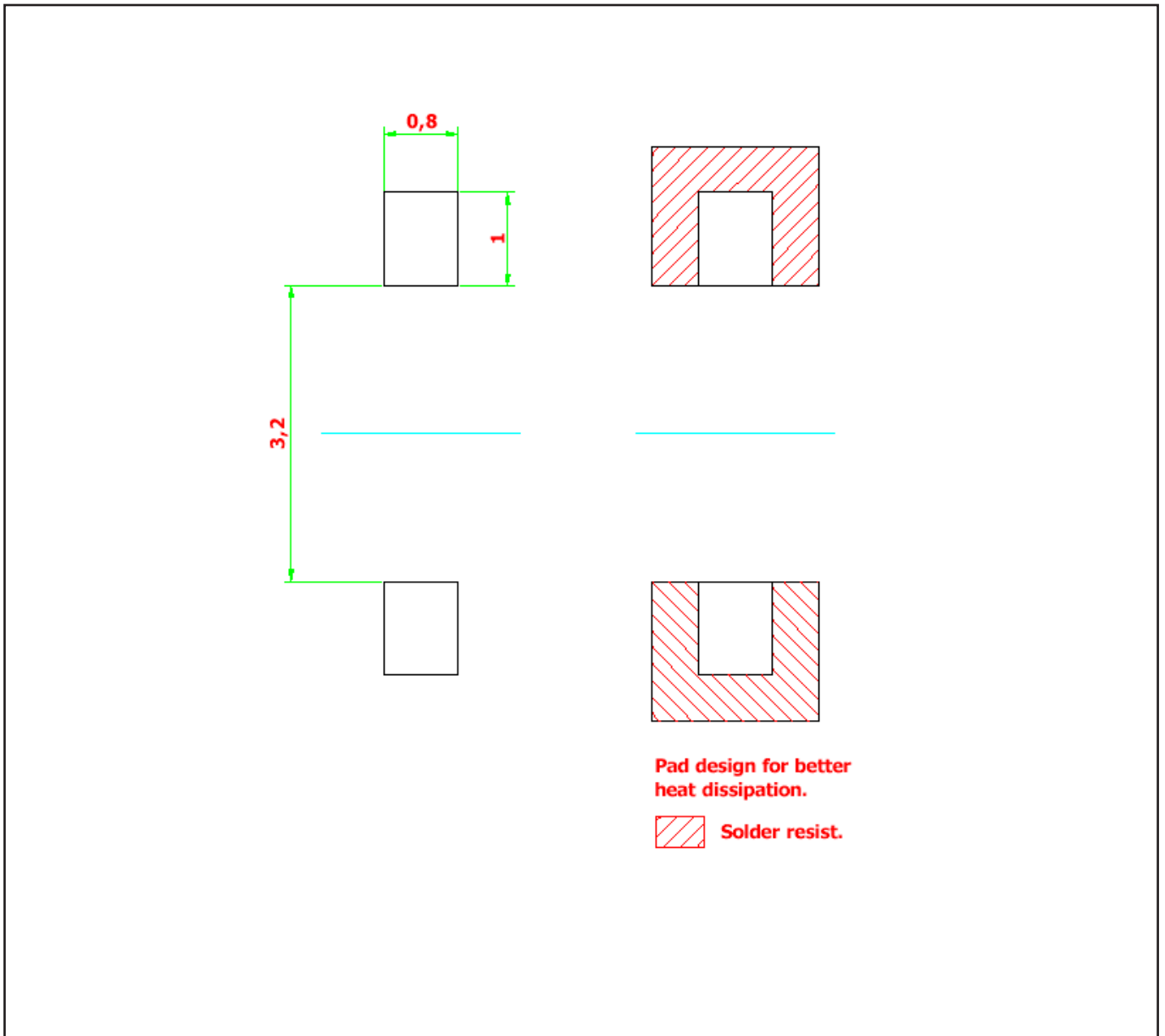

Taping and orientation *Appx. 5.1*

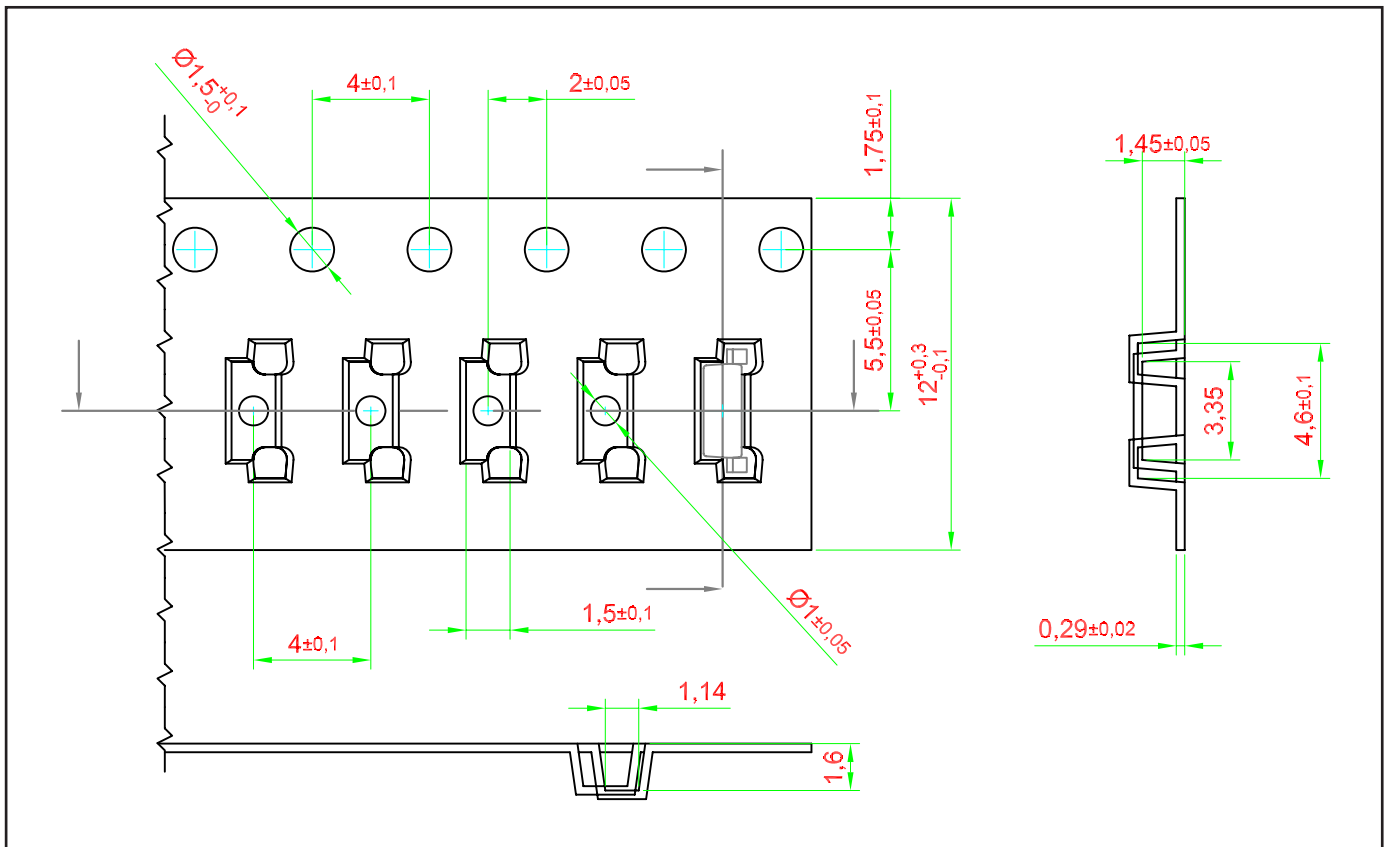

**Packaging Specification**

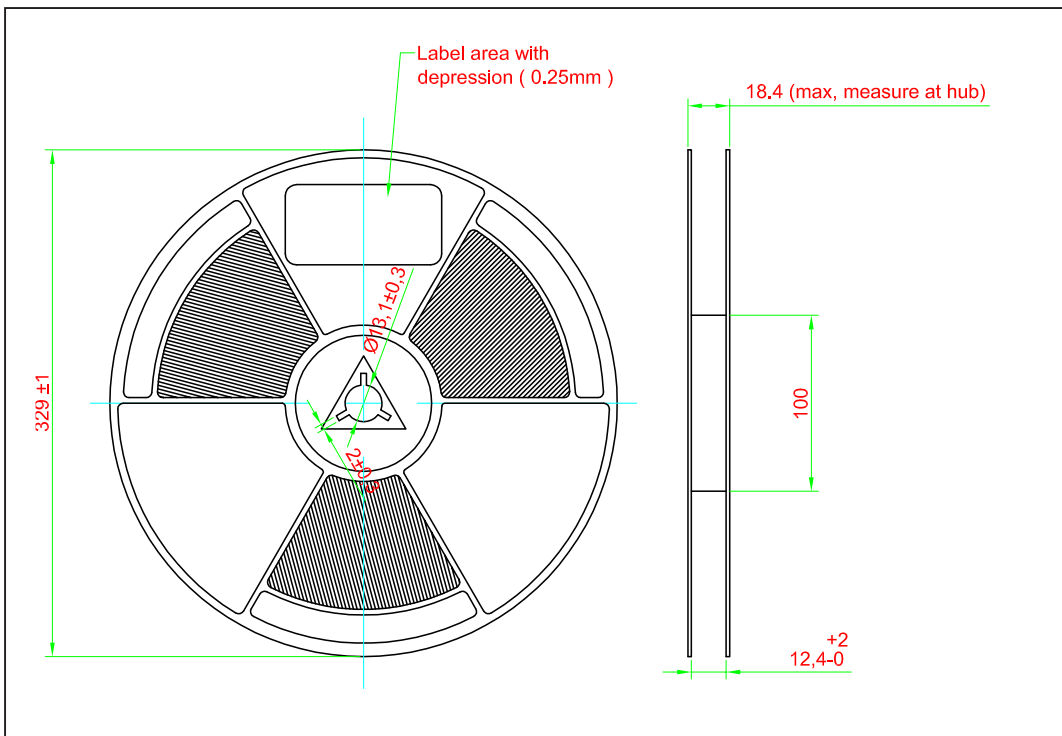
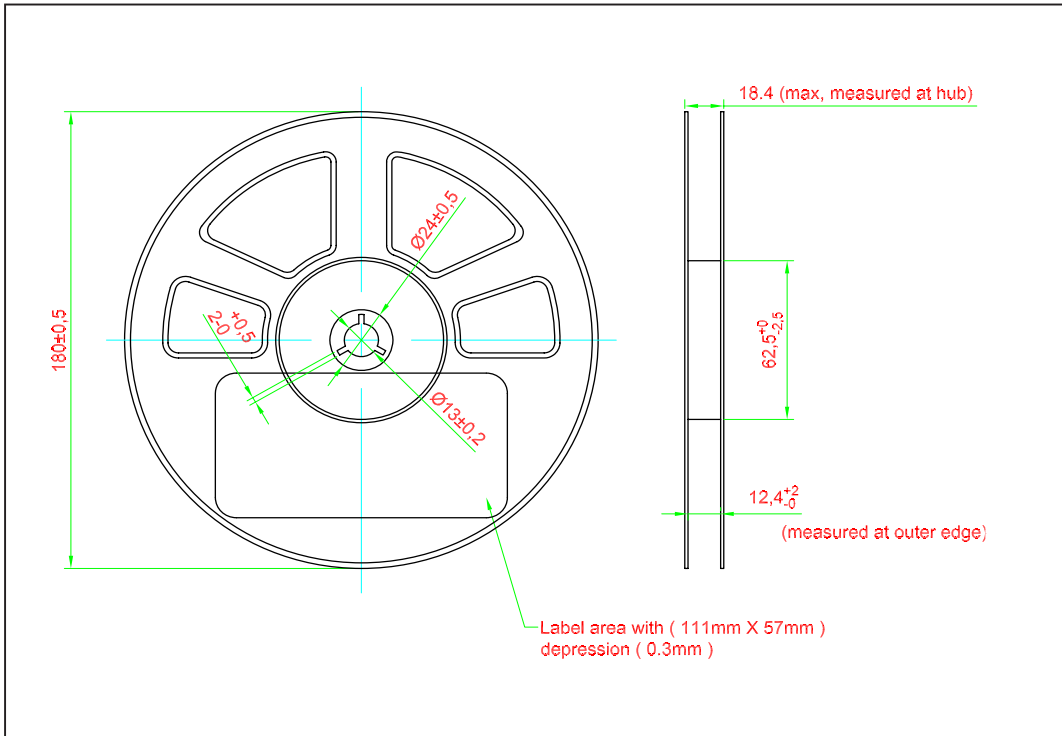

|                  | Reel Diameter (mm) | Quantity (pcs) | *Ordering Number |
|------------------|--------------------|----------------|------------------|
| Standard Packing | 180                | 2500           | DSZB-LSG-xxx-x   |
| Optional Packing | 329                | 9000           | DSZB-LSG-xxx-x-9 |

Notes:

\* For ordering purpose only. Please consult sales and marketing for details.

**Packaging Specification**

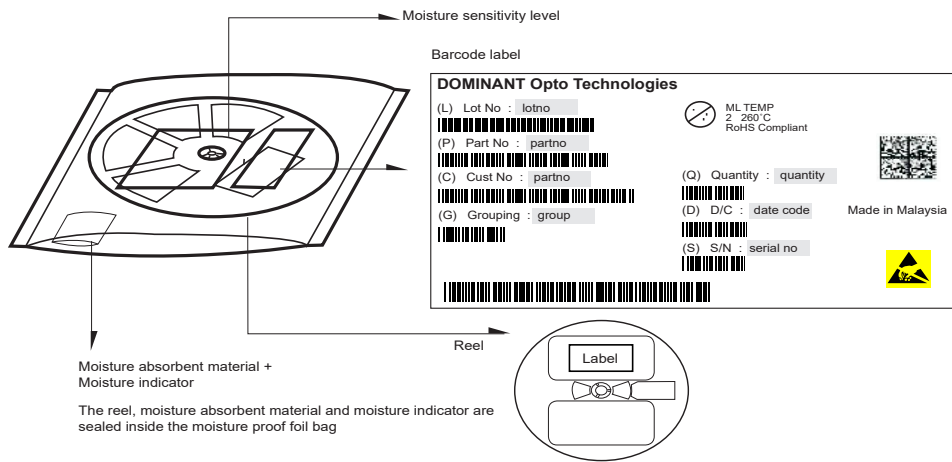

| Quantity per bag (pcs) | Average 1pc Right Angle DomiLED (g) | 1 completed bag (g) |
|------------------------|-------------------------------------|---------------------|
| 2500                   | 0.010                               | 240 ± 10            |
| 9000                   | 0.010                               | 520 ± 10            |

## Recommended Pb-free Soldering Profile

Product complies to MSL Level 2 acc. to JEDEC J-STD-020E

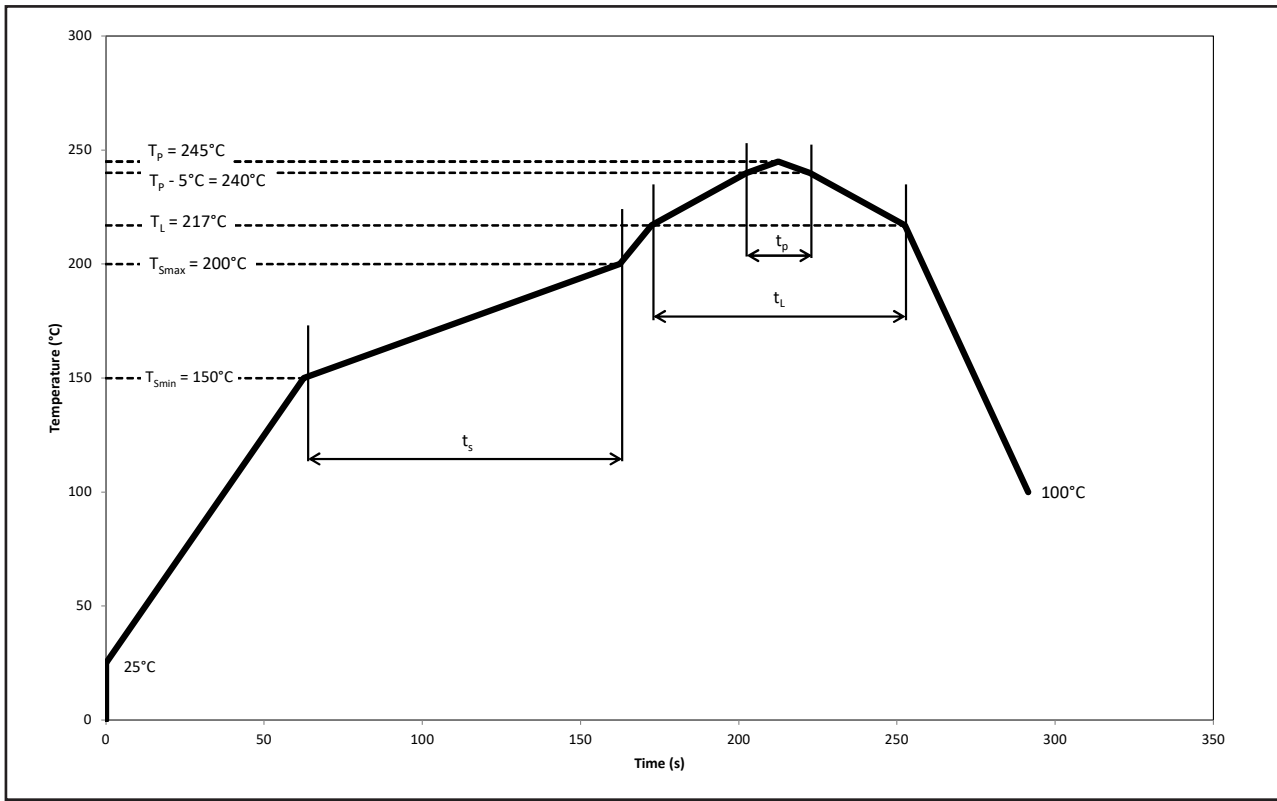

| Profile Feature  | Symbol | Pb-Free Assembly |             |      | Unit |
|--|--------|------------------|-------------|------|------|
|  |        | Min.             | Recommended | Max. |      |
| Ramp-up rate to preheat<br>25°C to $T_{smin}$                                | -      | -                | 2           | 3    | °C/s |
| Time $t_s$<br>$T_{smin}$ to $T_{smax}$                                       | $t_s$  | 60               | 100         | 120  | s    |
| Ramp-up rate to peak<br>$T_L$ to $T_p$                                       | -      | -                | 2           | 3    | °C/s |
| Liquidous temperature  | $T_L$  | -                | 217         | -    | °C   |
| Time above liquidous<br>temperature  | $t_L$  | 60               | 80          | 150  | s    |
| Peak temperature   | $T_p$  | -                | 245         | 260  | °C   |
| Time within 5°C of the specified<br>peak temperature $T_p - 5^\circ\text{C}$ | $t_p$  | 10               | 20          | 30   | s    |
| Ramp-down rate $T_p$ to 100°C  | -      | -                | 3           | 6    | °C/s |
| Time 25°C to $T_p$   | -      | -                | -           | 480  | s    |

---

## Appendix

### 1) **Brightness:**

- 1.1 Luminous intensity is measured at current pulse 25 ms(typ) with an internal reproducibility of  $\pm 8\%$  and an expanded uncertainty of  $\pm 11\%$  (according to GUM with a coverage factor of  $k=3$ ).
- 1.2 Luminous flux is measured at current pulse 25 ms(typ) with an internal reproducibility of  $\pm 8\%$  and an expanded uncertainty of  $\pm 11\%$  (according to GUM with a coverage factor of  $k=3$ ).
- 1.3 Radiant intensity is measured at current pulse 25 ms(typ) with an internal reproducibility of  $\pm 8\%$  and an expanded uncertainty of  $\pm 11\%$  (according to GUM with a coverage factor of  $k=3$ ).
- 1.4 Radiant flux is measured at current pulse 25 ms(typ) with an internal reproducibility of  $\pm 8\%$  and an expanded uncertainty of  $\pm 11\%$  (according to GUM with a coverage factor of  $k=3$ ).

### 2) **Color:**

- 2.1 Chromaticity coordinate groups are measured at current pulse 25 ms(typ) with an internal reproducibility of  $\pm 0.005$  and an expanded uncertainty of  $\pm 0.01$  (accordingly to GUM with a coverage factor of  $k=3$ ).
- 2.2 Dominant wavelength is measured at current pulse 25 ms(typ) with an internal reproducibility of  $\pm 0.5\text{nm}$  and an expanded uncertainty of  $\pm 1\text{nm}$  (accordingly to GUM with a coverage factor of  $k=3$ ).

### 3) **Voltage:**

- 3.1 Forward Voltage,  $V_f$  is measured when a current pulse of 8 ms(typ) with an internal reproducibility of  $\pm 0.05\text{V}$  and an expanded uncertainty of  $\pm 0.1\text{V}$  (accordingly to GUM with a coverage factor of  $k=3$ ).

### 4) **Typical Values:**

- 4.1 Due to the specific conditions of semiconductor devices' manufacturing processes, the provided typical data and calculated correlations of technical parameters should only be considered as statistical values. It is important to note that the actual parameters of individual devices may deviate from these typical data, calculated correlations or the typical characteristic line. Dominant reserves the right to update this typical data without prior notice, particularly in response to technical enhancements.

### 5) **Tolerance of Measure**

- 5.1 Unless otherwise noted in drawing, tolerances are specified with  $\pm 0.1$  and dimension are specified in mm.

### 6) **Reverse Voltage:**

- 6.1 Not designed for reverse operation. Continuous reverse voltage can cause migration and LED damage.

**Revision History**

| Page           | Subjects  | Date of Modification |
|----------------|---|----------------------|
| -              | Initial Release   | 06 May 2013          |
| 2              | Add new partno: DSZB-LSG-V2W-1  | 30 Aug 2013          |
| 1, 7, 9, 11    | Add Features<br>Add Notes in Packaging Outline<br>Update Carrier Tape<br>Update Packaging Specification                                 | 10 Mar 2016          |
| 1, 6, 7, 8, 14 | Update Product Photo<br>Update Features<br>Update Graph<br>Update Package Outline<br>Add Appendix                                       | 27 Apr 2017          |
| 1, 2, 12, 14   | Update Product Photo<br>Add Thermal Resistance Test Condition<br>Update Packaging Specification<br>Update Appendix                      | 07 Mar 2019          |
| 2, 11, 12, 13  | Not for New Design:<br>DSZB-LSG-V2W-1, DSZB-LSG-WX1-1<br>Update Packaging Specification<br>Update Recommended Pb-free Soldering Profile | 20 Jun 2022          |
| 8, 12          | Update Package Outline<br>Update Packaging Specification  | 10 Jul 2025          |

**NOTE**

All the information contained in this document is considered to be reliable at the time of publishing. However, DOMINANT Opto Technologies does not assume any liability arising out of the application or use of any product described herein.

DOMINANT Opto Technologies reserves the right to make changes to any products in order to improve reliability, function or design.

DOMINANT Opto Technologies products are not authorized for use as critical components in life support devices or systems without the express written approval from the Managing Director of DOMINANT Opto Technologies.

Dispose of product is in accordance with local, regional, national and international regulations.

## About Us

DOMINANT Opto Technologies is a dynamic company that is amongst the world's leading automotive LED manufacturers. With an extensive industry experience and relentless pursuit of innovation, DOMINANT's state-of-art manufacturing and development capabilities have become a trusted and reliable brand across the globe. More information about DOMINANT Opto Technologies, an IATF 16949 and ISO 14001 certified company, can be found under <http://www.dominant-semi.com>.

**Please contact us for more information:**

DOMINANT Opto Technologies Sdn. Bhd  
Lot 6, Batu Berendam, FTZ Phase III, 75350 Melaka, Malaysia.  
Tel: +606 283 3566 Fax: +606 283 0566  
E-mail: [sales@dominant-semi.com](mailto:sales@dominant-semi.com)

---