

Domiled

Synonymous with function and performance, the Domiled series is perfectly suited for a variety of cross-industrial applications due to its small package outline, durability and superior brightness.



Features:

- > High brightness surface mount LED using thin film technology.
- > 120° viewing angle.
- > Small package outline (LxWxH) of 3.2 x 2.8 x 1.8mm.
- > Qualified according to JEDEC moisture sensitivity Level 2.
- > Compatible to IR reflow soldering.
- > Environmental friendly; RoHS compliance.
- > Compliance to automotive standard; AEC-Q102.
- > Passed Corrosion Resistant Test. *Appx. 7.1*



Applications:

- > Automotive: interior applications, eg: switches, telematics, climate control system, dashboard, etc.
- > Display: full color display video notice board.
- > Industrial: white goods (eg: Oven, microwave, etc.).



Optical Characteristics at Tj=25°C

| Part Number | Color | Viewing Angle° | Luminous Intensity @ IF = 20mA IV (mcd) <i>Appx. 1.1</i> | | |
|---------------|------------------|----------------|--|-------|-------|
| | | | Min. | Typ. | Max. |
| DRS-NRS-TU1-1 | Super Red, 632nm | 120 | 285.0 | 355.0 | 560.0 |
| DRR-NRS-T2U-1 | Red, 625nm | 120 | 355.0 | 450.0 | 715.0 |
| DRA-NRS-UV1-1 | Amber, 615nm | 120 | 450.0 | 560.0 | 900.0 |
| DRO-NRS-UV1-1 | Orange, 605nm | 120 | 450.0 | 560.0 | 900.0 |
| DRY-NRS-UV1-1 | Yellow, 587nm | 120 | 450.0 | 560.0 | 900.0 |

Electrical Characteristics at Tj=25°C

| Part Number | Vf @ If = 20mA <i>Appx. 3.1</i> | | | Vr @ Ir = 10uA <i>Appx. 6.1</i> |
|-------------|---------------------------------|----------|----------|---------------------------------|
| | Min. (V) | Typ. (V) | Max. (V) | Min. (V) |
| DRx-NRS | 1.8 | 2.1 | 2.6 | 12 |

Absolute Maximum Ratings

| | Maximum Value | Unit |
|--|---------------|------|
| DC forward current | 50 | mA |
| Peak pulse current; (Ts=55°C, tp ≤ 100µs, Duty cycle = 0.03) | 100 | mA |
| Reverse voltage <i>Appx. 6.1</i> | 12 | V |
| ESD threshold (HBM) | 2 | kV |
| LED junction temperature | 120 | °C |
| Operating temperature | -40 ... +105 | °C |
| Storage temperature | -40 ... +110 | °C |
| Power dissipation (at room temperature) | 80 | mW |
| Thermal resistance (Rated current = 20mA, Ts=25 °C) | | |
| - Real Thermal Resistance | | |
| Junction / solder point, Rth JS real | 115 | K/W |

Wavelength Grouping at Tj=25°C

| Color | Group | Wavelength distribution (nm) <i>Appx. 2.2</i> |
|----------------|-------|---|
| DRS; Super Red | Full | 625 - 640 |
| DRR; Red | Full | 620 - 630 |
| DRA; Amber | Full | 610 - 621 |
| | W | 610 - 615 |
| | X | 615 - 621 |
| DRO; Orange | Full | 600 - 612 |
| | W | 600 - 603 |
| | X | 603 - 606 |
| | Y | 606 - 609 |
| | Z | 609 - 612 |
| DRY; Yellow | Full | 582 - 594 |
| | W | 582 - 585 |
| | X | 585 - 588 |
| | Y | 588 - 591 |
| | Z | 591 - 594 |

Luminous Intensity Group at Tj=25°C

| Brightness Group | Luminous Intensity <i>Appx. 1.1</i> IV (mcd) |
|------------------|---|
| T1 | 285.0...355.0 |
| T2 | 355.0...450.0 |
| U1 | 450.0...560.0 |
| U2 | 560.0...715.0 |
| V1 | 715.0...900.0 |

Relative Luminous Intensity Vs Forward Current

$I_v/I_v(20\text{mA}) = f(I_F); T_j = 25^\circ\text{C}$

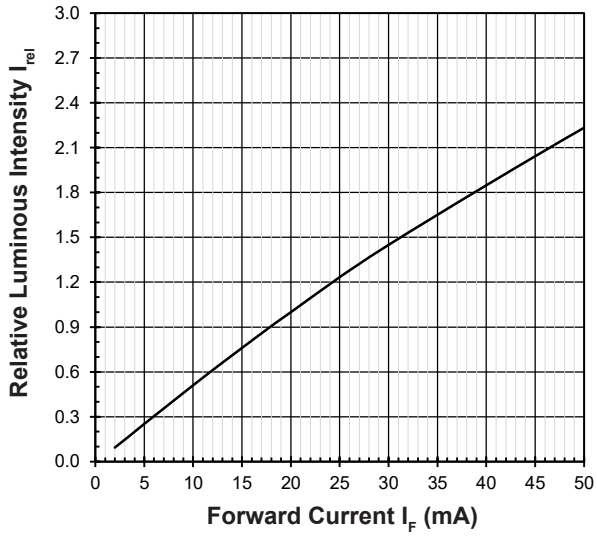

Forward Current Vs Forward Voltage

$I_F = f(V_F); T_j = 25^\circ\text{C}$

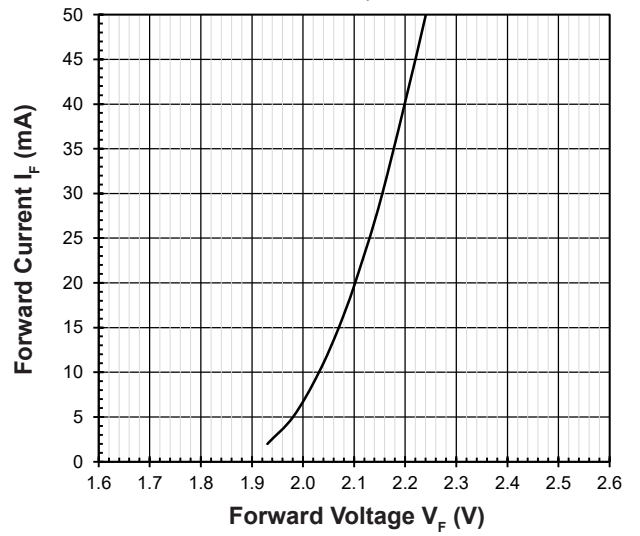

Maximum Current Vs Temperature

$I_F = f(T)$

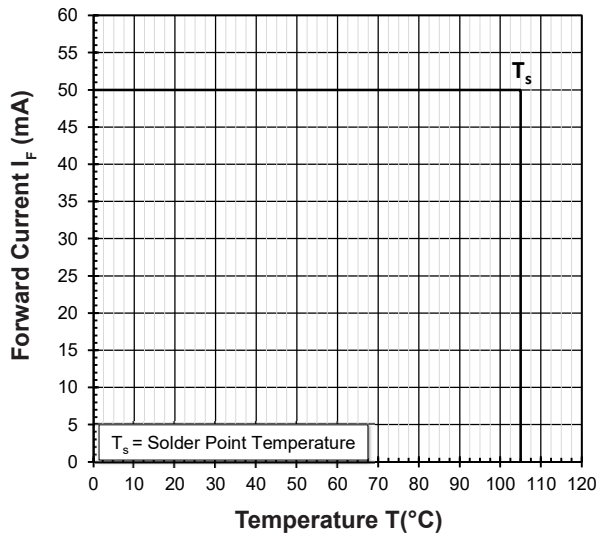

Relative Spectral Emission

$I_{rel} = f(\lambda); T_j = 25^\circ\text{C}; I_F = 20\text{mA}$

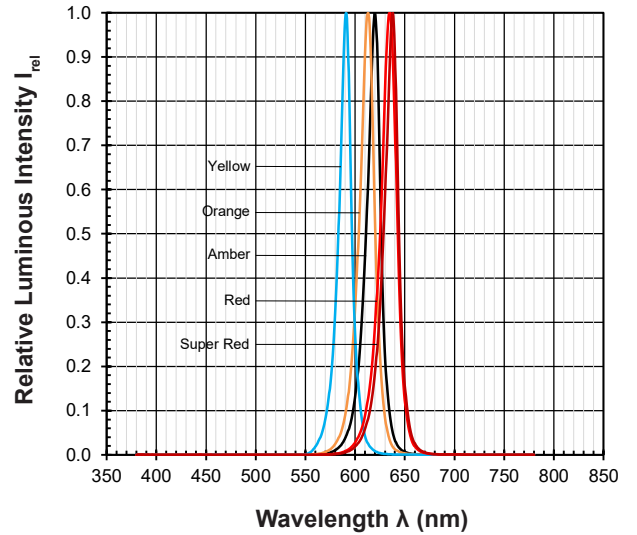

Allowable Forward Current Vs Duty Ratio

$(T_s = 55^\circ\text{C}; t_p \leq 100\mu\text{s})$

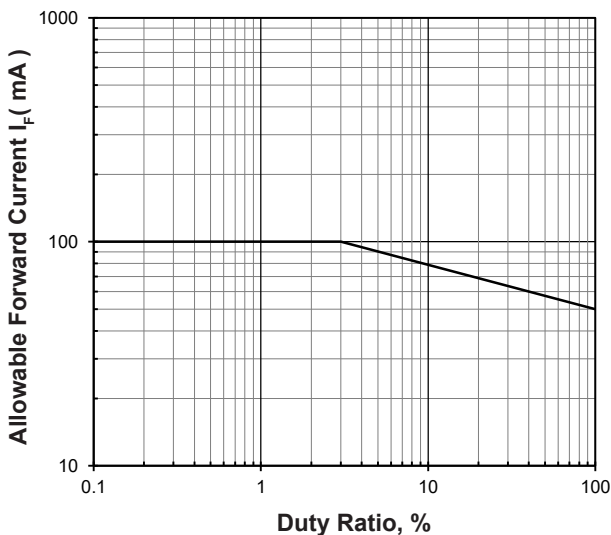

Radiation Pattern

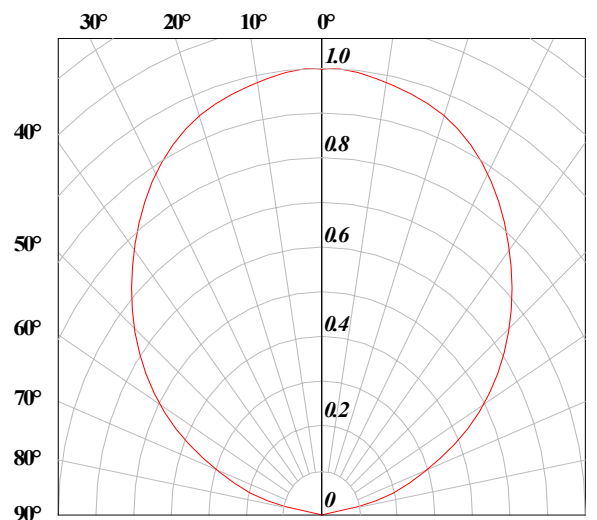

Forward Voltage Vs Junction Temperature

$$\Delta V_F = V_F - V_F(25^\circ\text{C}) = f(T_j); I_F = 20\text{mA}$$

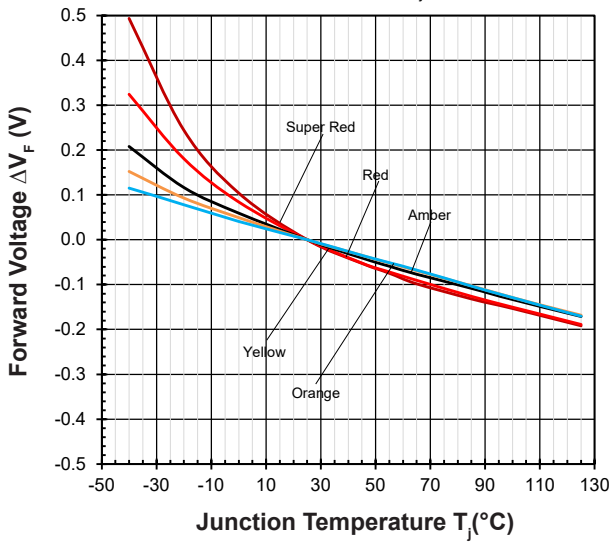

Relative Luminous Intensity Vs Junction Temperature

$$I_V/I_V(25^\circ\text{C}) = f(T_j); I_F = 20\text{mA}$$

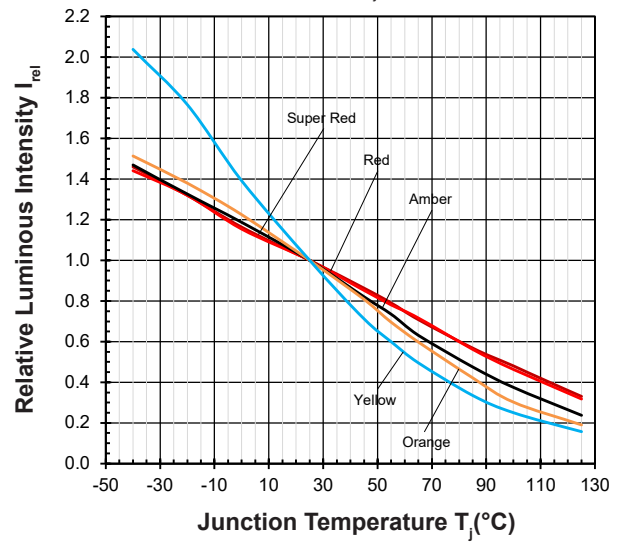

Wavelength Vs Junction Temperature

$$\Delta \lambda_{dom} = \lambda_{dom} - \lambda_{dom}(25^\circ\text{C}) = f(T_j); I_F = 20\text{mA}$$

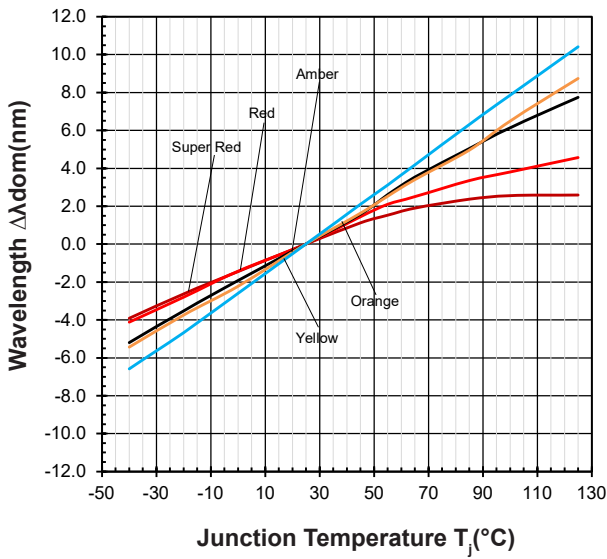

DomiLED • AllnGaP : DRx-NRS Package Outlines

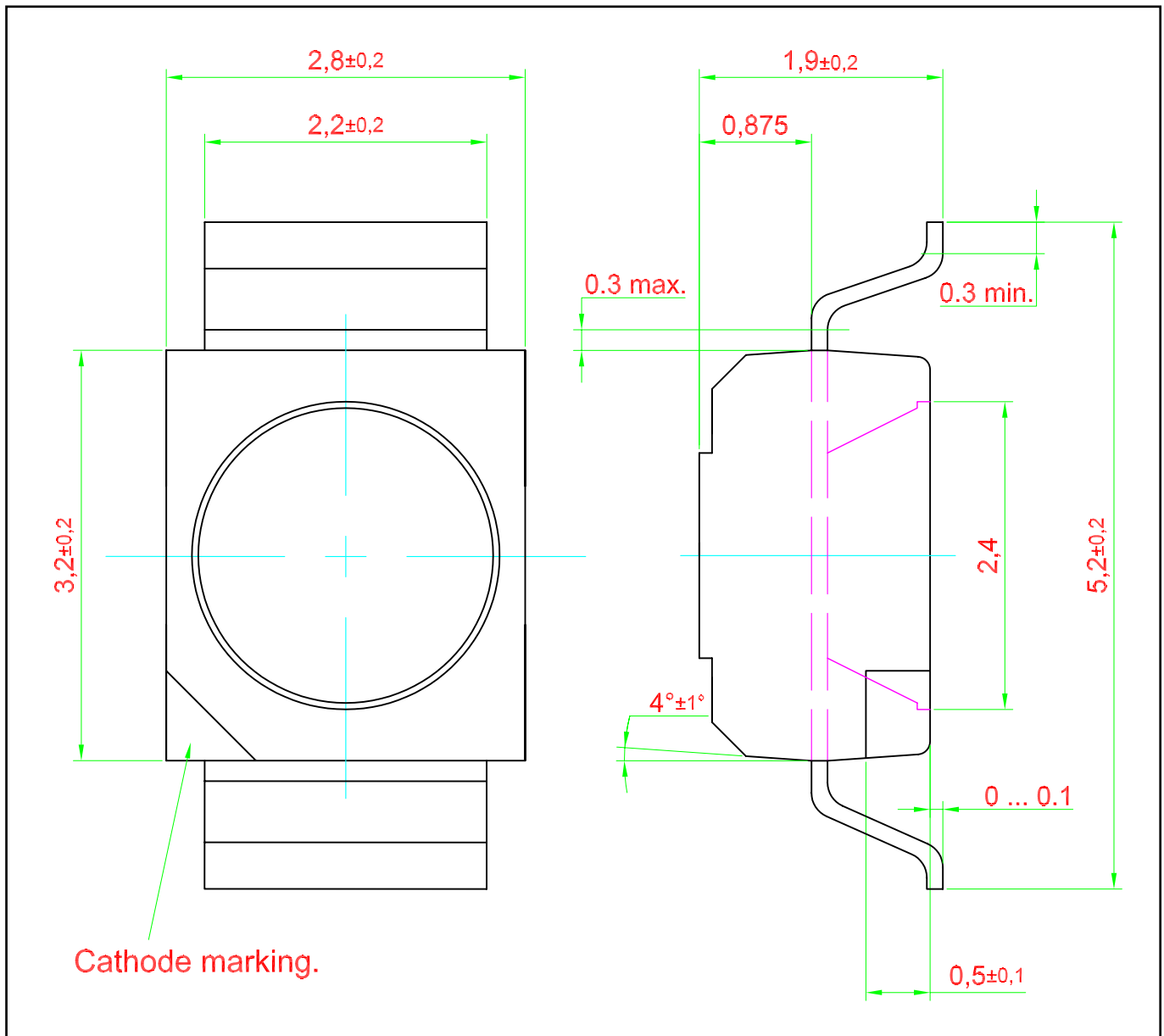

Material

| Material | |
|-----------------|------------------------------------|
| Lead-frame | Cu Alloy With Ag Plating |
| Package | High Temperature Resistant Plastic |
| Encapsulant | Epoxy Resin |
| Soldering Leads | Sn Plating |

Recommended Solder Pad

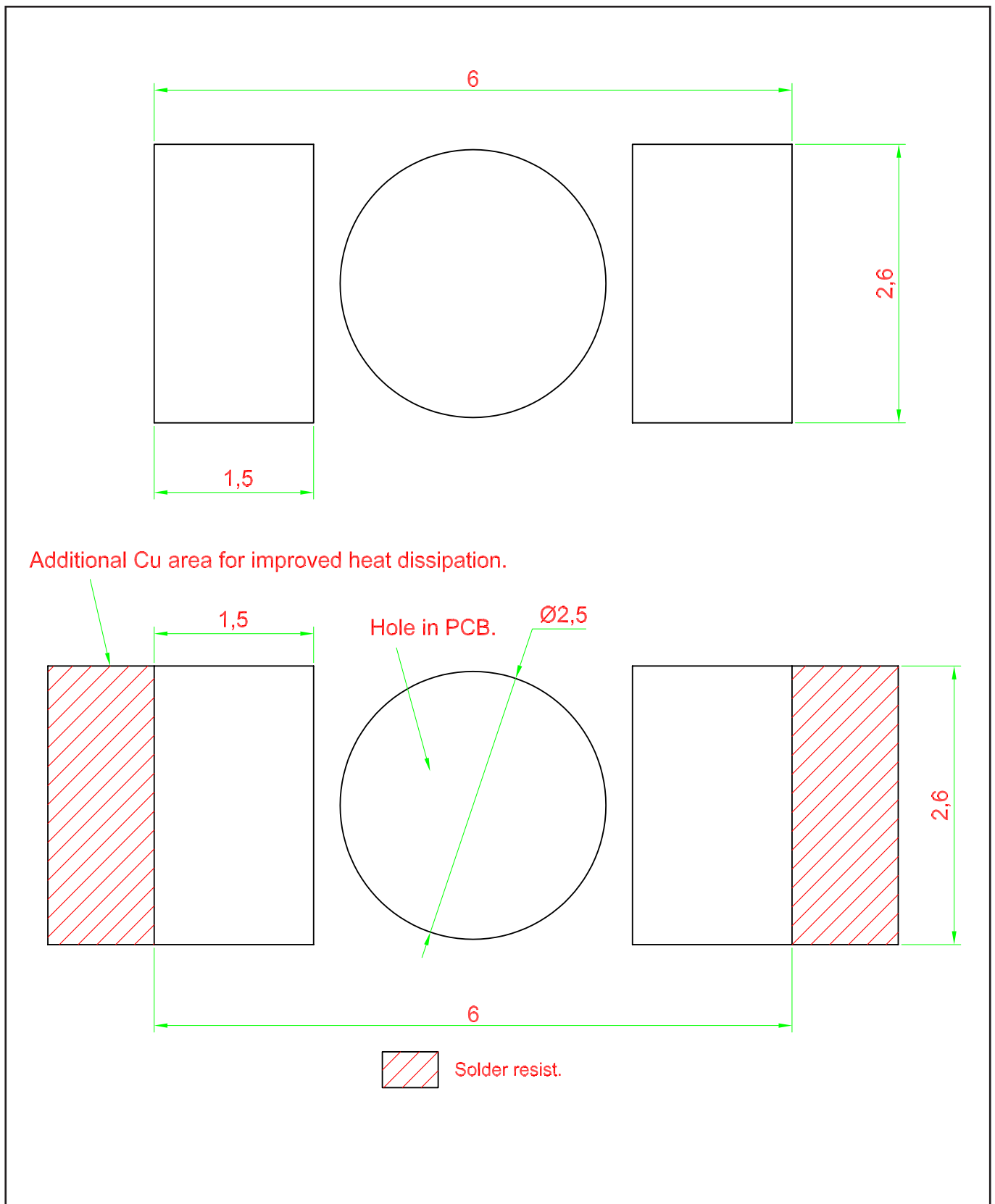

Packaging Specification

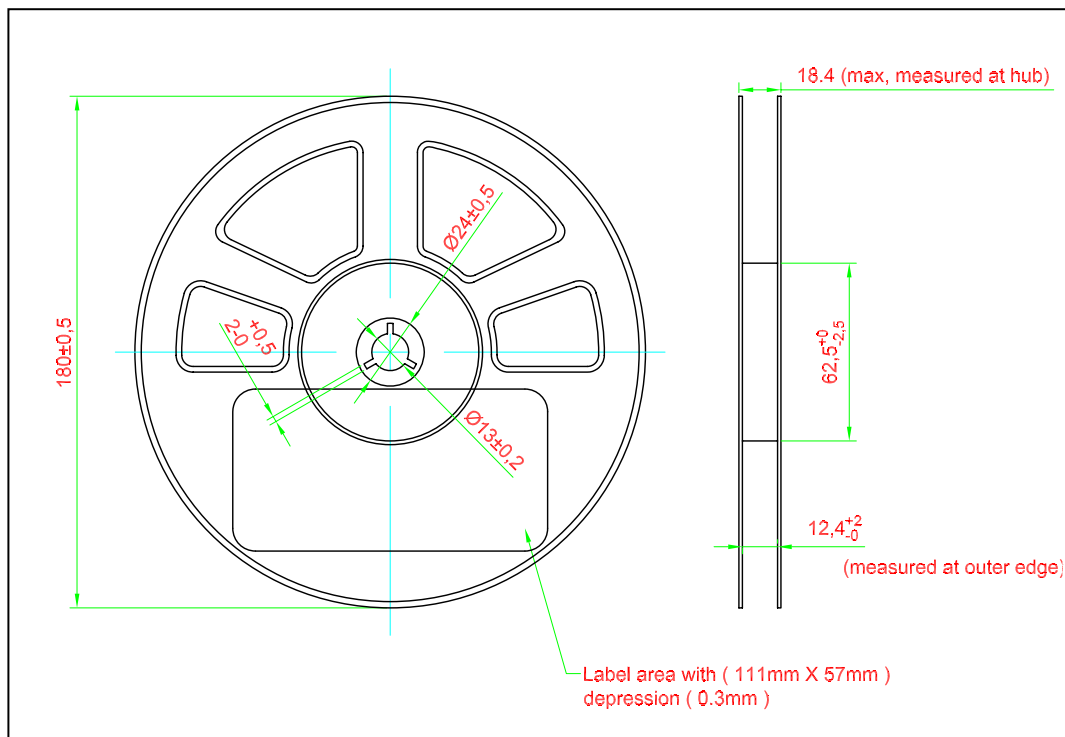

| | Reel Diameter (mm) | Quantity (pcs) | *Ordering Number |
|------------------|--------------------|----------------|------------------|
| Standard Packing | 180 | 2000 | DRx-NRS-xxx-x |

Notes:

* For ordering purpose only. Please consult sales and marketing for details.

Packaging Specification

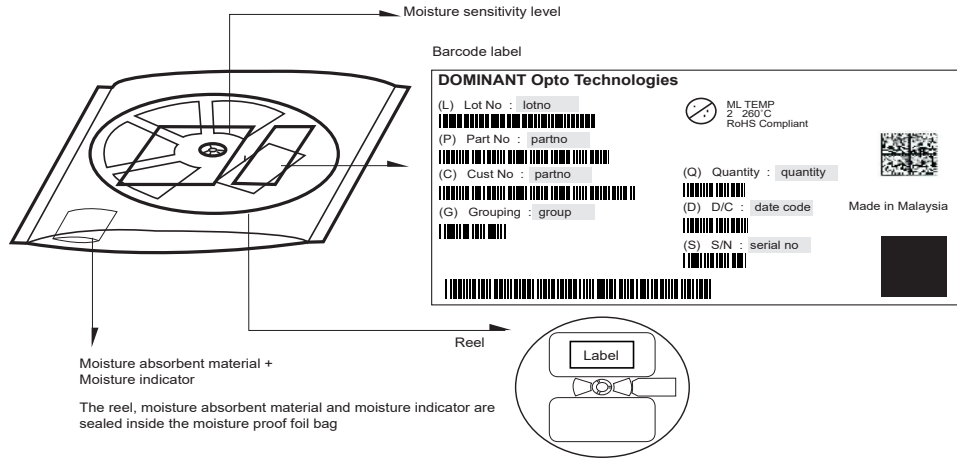

| Quantity per bag (pcs) | Average 1pc DomiLED (gram) | 1 completed bag (gram) |
|------------------------|----------------------------|------------------------|
| 2000 | 0.034 | 240 ± 10 |

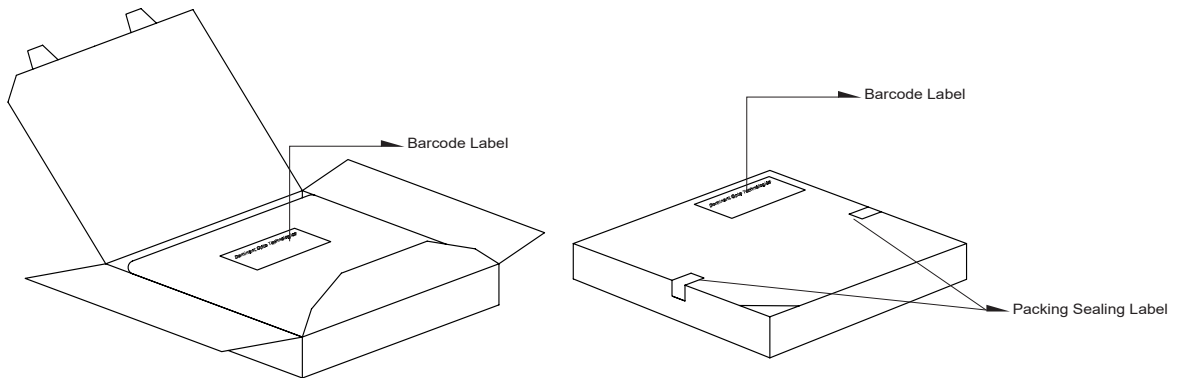

| Reel Diameter (mm) | Packing Box Dimensions (mm) |
|--------------------|-----------------------------|
| 180 | 210 x 210 x 20 |

Recommended Pb-free Soldering Profile

Product complies to MSL Level 2 acc. to JEDEC J-STD-020E

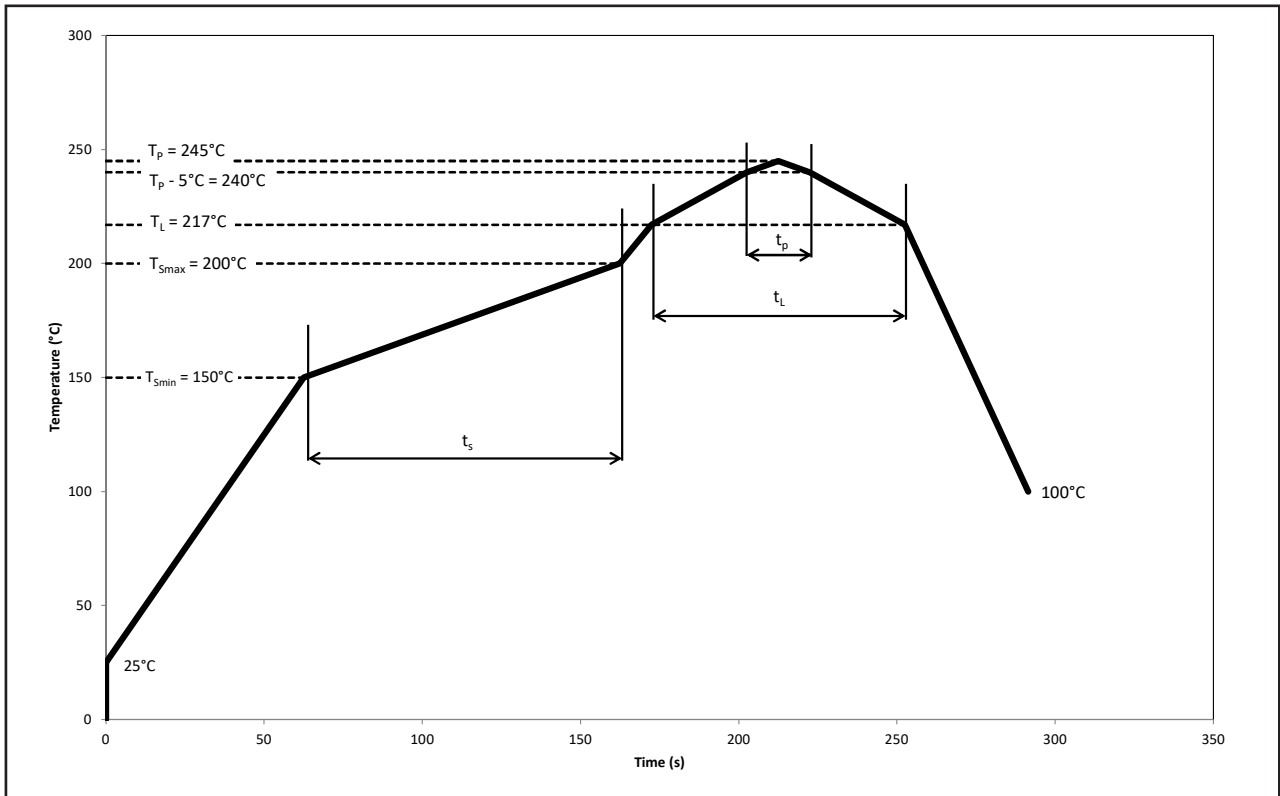

| Profile Feature | Symbol | Pb-Free Assembly | | | Unit |
|--|--------|------------------|-------------|------|------|
| | | Min. | Recommended | Max. | |
| Ramp-up rate to preheat 25°C to T_{smin} | - | - | 2 | 3 | °C/s |
| Time t_s T_{smin} to T_{smax} | t_s | 60 | 100 | 120 | s |
| Ramp-up rate to peak T_L to T_p | - | - | 2 | 3 | °C/s |
| Liquidous temperature | T_L | - | 217 | - | °C |
| Time above liquidous temperature | t_L | 60 | 80 | 150 | s |
| Peak temperature | T_p | - | 245 | 260 | °C |
| Time within 5°C of the specified peak temperature $T_p - 5^\circ\text{C}$ | t_p | 10 | 20 | 30 | s |
| Ramp-down rate T_p to 100°C | - | - | 3 | 6 | °C/s |
| Time 25°C to T_p | - | - | - | 480 | s |

Appendix

1) **Brightness:**

- 1.1 Luminous intensity is measured at current pulse 25 ms(typ) with an internal reproducibility of $\pm 8\%$ and an expanded uncertainty of $\pm 11\%$ (according to GUM with a coverage factor of $k=3$).
- 1.2 Luminous flux is measured at current pulse 25 ms(typ) with an internal reproducibility of $\pm 8\%$ and an expanded uncertainty of $\pm 11\%$ (according to GUM with a coverage factor of $k=3$).
- 1.3 Radiant intensity is measured at current pulse 25 ms(typ) with an internal reproducibility of $\pm 8\%$ and an expanded uncertainty of $\pm 11\%$ (according to GUM with a coverage factor of $k=3$).
- 1.4 Radiant flux is measured at current pulse 25 ms(typ) with an internal reproducibility of $\pm 8\%$ and an expanded uncertainty of $\pm 11\%$ (according to GUM with a coverage factor of $k=3$).

2) **Color:**

- 2.1 Chromaticity coordinate groups are measured at current pulse 25 ms(typ) with an internal reproducibility of ± 0.005 and an expanded uncertainty of ± 0.01 (accordingly to GUM with a coverage factor of $k=3$).
- 2.2 Dominant wavelength is measured at current pulse 25 ms(typ) with an internal reproducibility of $\pm 0.5\text{nm}$ and an expanded uncertainty of $\pm 1\text{nm}$ (accordingly to GUM with a coverage factor of $k=3$).

3) **Voltage:**

- 3.1 Forward Voltage, V_f is measured when a current pulse of 8 ms(typ) with an internal reproducibility of $\pm 0.05\text{V}$ and an expanded uncertainty of $\pm 0.1\text{V}$ (accordingly to GUM with a coverage factor of $k=3$).

4) **Typical Values:**

- 4.1 At special conditions of LED manufacturing processes, typical data or calculated correlations of technical parameters only reflect the statistical figures. But not necessarily correspond to the actual parameters of each single product, which could differ from the typical data or calculated correlations or the typical characteristic line. These typical data may change whenever technical improvements happen.

5) **Tolerance of Measure**

- 5.1 Unless otherwise noted in drawing, tolerances are specified with ± 0.1 and dimension are specific in mm.

6) **Reverse Voltage:**

- 6.1 Not designed for reverse operation. Continuous reverse voltage can cause migration and LED damage.

7) **Corrosion Robustness:**

- 7.1 Test conditions: $40\text{ }^\circ\text{C} / 90\% \text{ rh} / 15 \text{ ppm H}_2\text{S} / 336 \text{ h}$.
= Stricter than IEC 60068-2-43 (H_2S) [$25\text{ }^\circ\text{C} / 75\% \text{ rh} / 10 \text{ ppm H}_2\text{S} / 21 \text{ days}$].

8) **Thermal Resistance**

- 8.1 $R_{th \text{ max}}$ is based on statistic values (6σ).

Revision History

| Page | Subjects | Date of Modification |
|--------------------------|---|-----------------------------|
| - | Initial Release | 12 Aug 2009 |
| - | Update company name | 31 May 2010 |
| 3 | Add characteristics | 12 Jul 2010 |
| 9 | Error in carrier tape | 22 Jun 2012 |
| 1, 10 | Add Features Update Package Specification | 16 Oct 2015 |
| 1, 10, 12 | Update Product Photo Error on Packaging Specification Add Appendix | 03 Jul 2017 |
| 1, 2, 4, 5, 9, 10, 11 | Update AEC-Q101 to AEC-Q102 Update Operating & Storage Temperature Add Thermal Resistance Update Graph Update Packaging Specification Update Recommended Pb-free Soldering Profile | 07 Jun 2022 |
| | | |

NOTE

All the information contained in this document is considered to be reliable at the time of publishing. However, DOMINANT Opto Technologies does not assume any liability arising out of the application or use of any product described herein.

DOMINANT Opto Technologies reserves the right to make changes to any products in order to improve reliability, function or design.

DOMINANT Opto Technologies products are not authorized for use as critical components in life support devices or systems without the express written approval from the Managing Director of DOMINANT Opto Technologies.

Dispose of product is in accordance with local, regional, national and international regulations.

About Us

DOMINANT Opto Technologies is a dynamic company that is amongst the world's leading automotive LED manufacturers. With an extensive industry experience and relentless pursuit of innovation, DOMINANT's state-of-art manufacturing and development capabilities have become a trusted and reliable brand across the globe. More information about DOMINANT Opto Technologies, an IATF 16949 and ISO 14001 certified company, can be found under <http://www.dominant-semi.com>.

Please contact us for more information:

DOMINANT Opto Technologies Sdn. Bhd.
Lot 6, Batu Berendam, FTZ Phase III, 75350 Melaka, Malaysia
Tel: (606) 283 3566 Fax: (606) 283 0566
E-mail: sales@dominant-semi.com
