

### Mini DomiLED

With the intense colors that seem to glow with energy and its significant brightness, Mini DomiLED white LED is a highly reliable design device. Its dynamic nature makes it perfect choice for lighthing applications, office and home applications and standard industrial applications.



### Features:

- > High brightness surface mount LED.
- > Based on InGaN technology.
- > 120° viewing angle.
- > Small package outline (LxWxH) of 2.0 x 1.4 x 1.3mm.
- > Qualified according to JEDEC moisture sensitivity Level 2.
- > Compatible to both IR reflow soldering.
- > Environmental friendly; RoHS compliance.
- > Compliance to automotive standard; AEC-Q102.
- > Passed Corrosion Resistant Test. *Appx. 7.1*



### Applications:

- > Automotive: interior applications, eg: switches, telematics, climate control system, dashboard, etc.
- > Communication: indicator and backlight in mobilephone.
- > Display: full color display video notice board.
- > Industry: white goods (eg: Oven, microwave, etc.).

**Optical Characteristics at Tj=25°C**

Part Number	Viewing Angle°	Luminous Intensity @ IF = 2mA IV (mcd) <i>Appx. 1.1</i>		
		Min.	Typ.	Max.
DNZB-DJG-K2N1-1-I2	120	9.0	18.0	35.5

**Electrical Characteristics at Tj=25°C**

Part Number	Vf @ If = 2 mA <i>Appx. 3.1</i>			Vr @ Ir = 10 µA
	Min. (V)	Typ. (V)	Max. (V)	Min. (V)
DNZB-DJG	2.6	3.0	3.5	5.0

**Absolute Maximum Ratings**

	Maximum Value	Unit
DC forward current	20	mA
Peak pulse current; (Ts = 55°C, tp ≤ 100µs, Duty cycle = 0.03)	100	mA
Reverse voltage	5	V
ESD threshold (HBM)	2000	V
LED junction temperature	110	°C
Operating temperature	-40 ... +105	°C
Storage temperature	-40 ... +105	°C
Power dissipation (at room temperature)	70	mW
Thermal resistance		
- Junction / ambient, Rth JA	530	K/W
- Junction / solder point, Rth JS	280	K/W

**DNZB-DJG Color Grouping** *Appx. 2.1*

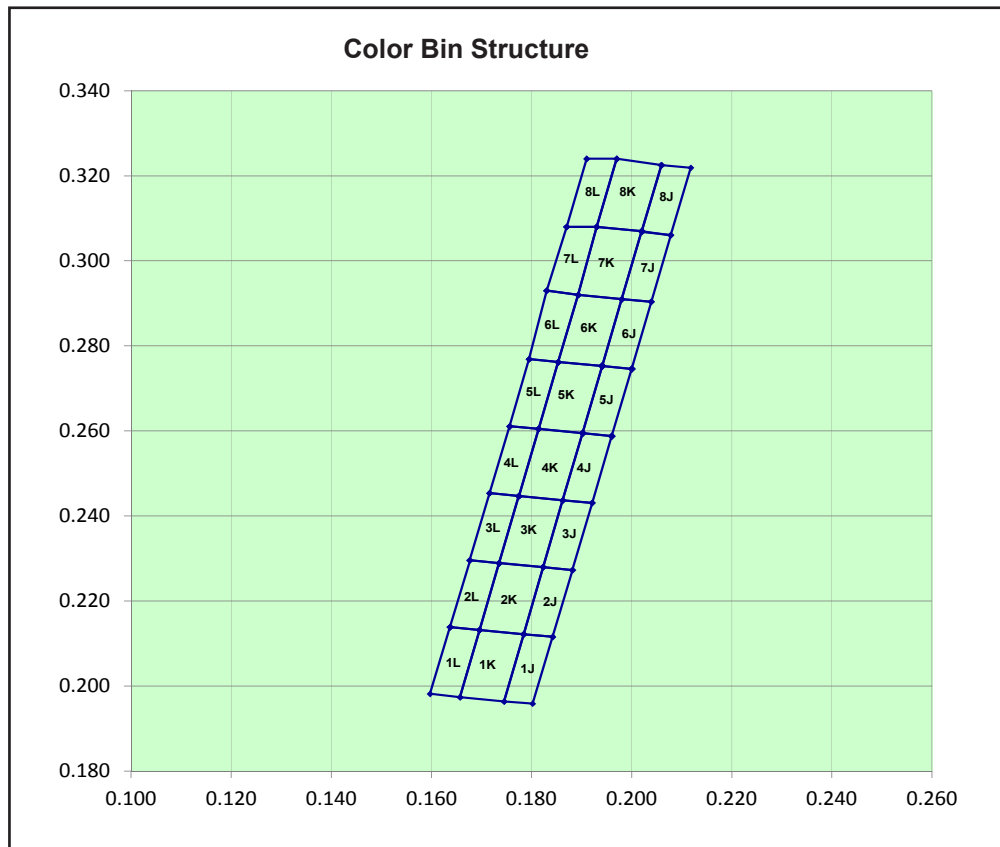

Bin		1	2	3	4
2J	Cx	0.1784	0.1842	0.1882	0.1823
	Cy	0.2122	0.2116	0.2273	0.2280
2K	Cx	0.1696	0.1784	0.1823	0.1735
	Cy	0.2132	0.2122	0.2280	0.2290
2L	Cx	0.1637	0.1696	0.1735	0.1677
	Cy	0.2139	0.2132	0.2296	0.2296
3J	Cx	0.1862	0.1823	0.1881	0.1921
	Cy	0.2437	0.2280	0.2273	0.2431
3K	Cx	0.1774	0.1735	0.1823	0.1862
	Cy	0.2447	0.2289	0.2280	0.2437
3L	Cx	0.1716	0.1676	0.1735	0.1774
	Cy	0.2454	0.2296	0.2289	0.2447
4J	Cx	0.1902	0.1862	0.1921	0.1960
	Cy	0.2595	0.2437	0.2431	0.2588
4K	Cx	0.1814	0.1775	0.1862	0.1902
	Cy	0.2605	0.2447	0.2437	0.2595
4L	Cx	0.1756	0.1716	0.1775	0.1814
	Cy	0.2611	0.2454	0.2447	0.2605
5J	Cx	0.1941	0.1902	0.1960	0.2000
	Cy	0.2753	0.2595	0.2588	0.2746
5K	Cx	0.1853	0.1814	0.1902	0.1941
	Cy	0.2762	0.2605	0.2595	0.2753
5L	Cx	0.1795	0.1756	0.1814	0.1853
	Cy	0.2769	0.2611	0.2605	0.2762

Bin		1	2	3	4
6J	Cx	0.1980	0.1941	0.2000	0.2039
	Cy	0.2910	0.2753	0.2746	0.2904
6K	Cx	0.1893	0.1853	0.1941	0.1980
	Cy	0.2920	0.2762	0.2753	0.2910
6L	Cx	0.1830	0.1795	0.1853	0.1893
	Cy	0.2930	0.2769	0.2762	0.2920
7J	Cx	0.2020	0.1980	0.2039	0.2078
	Cy	0.3070	0.2910	0.2904	0.3060
7K	Cx	0.1930	0.1893	0.1980	0.2020
	Cy	0.3080	0.2920	0.2910	0.3070
7L	Cx	0.1870	0.1830	0.1893	0.1930
	Cy	0.3080	0.2930	0.2920	0.3080
8J	Cx	0.2059	0.2020	0.2078	0.2118
	Cy	0.3225	0.3068	0.3061	0.3219
8K	Cx	0.1970	0.1930	0.2020	0.2060
	Cy	0.3240	0.3080	0.3070	0.3230
8L	Cx	0.1910	0.1870	0.1930	0.1970
	Cy	0.3240	0.3080	0.3080	0.3240

InGaN wavelength is very sensitive to drive current. Operating at lower current is not recommended and may yield unpredictable performance. Current pulsing should be used for dimming purposes.

**Luminous Intensity Group at Tj=25°C**

Brightness Group	Luminous Intensity <i>Appx. 1.1</i> IV (mcd)
K2	9.00...11.20
L1	11.20...14.00
L2	14.00...18.00
M1	18.00...22.40
M2	22.40...28.50
N1	28.50...35.50

**Vf Binning (Optional)**

Vf @ If = 2mA	Forward Voltage (V) <i>Appx. 3.1</i>
V5	2.60 ... 2.90
V6	2.90 ... 3.20
V7	3.20 ... 3.50

Please consult sales and marketing for special part number to incorporate Vf binning.

**Relative Luminous Intensity Vs Forward Current** *Appx. 4.1*

$$I_v/I_v(2mA) = f(I_F); T_j = 25^\circ C$$

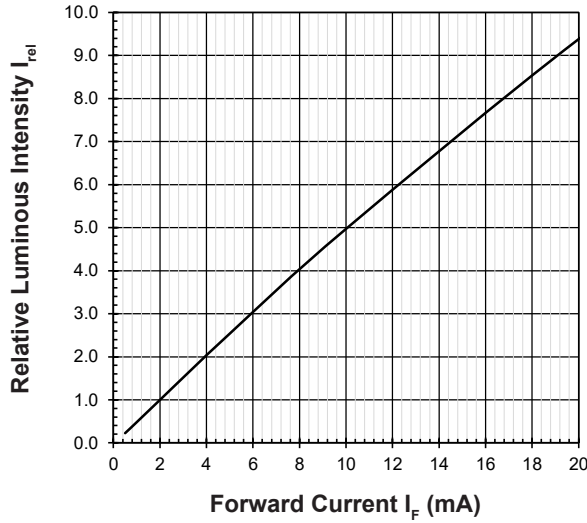

**Forward Current Vs Forward Voltage** *Appx. 4.1*

$$I_F = f(V_F); T_j = 25^\circ C$$

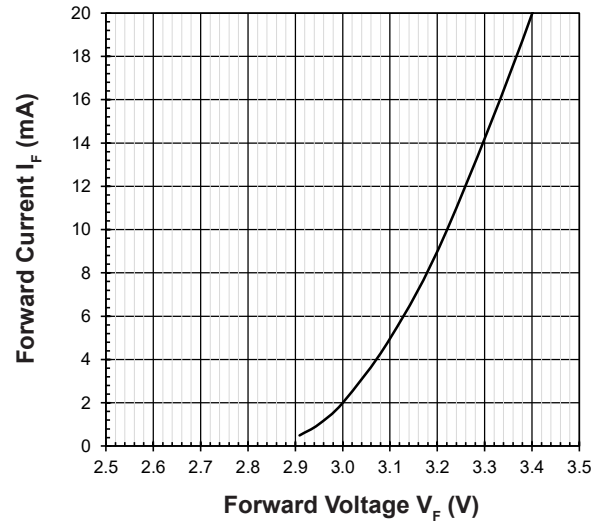

**Maximum Current Vs Temperature**

$$I_F = f(T)$$

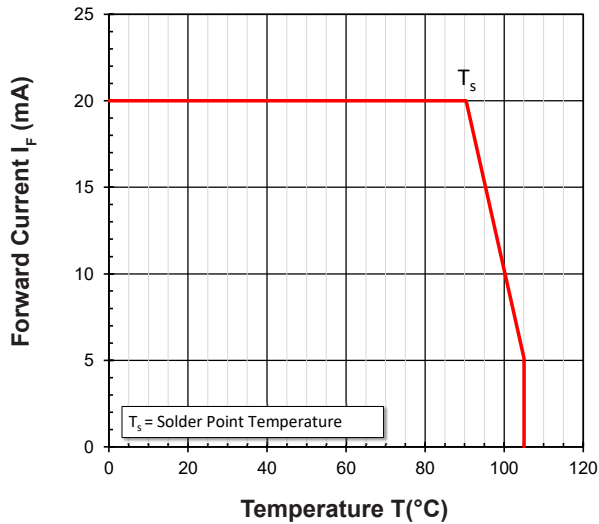

**Relative Spectral Emission** *Appx. 4.1*

$$I_{rel} = f(\lambda); T_j = 25^\circ C; I_F = 2mA$$

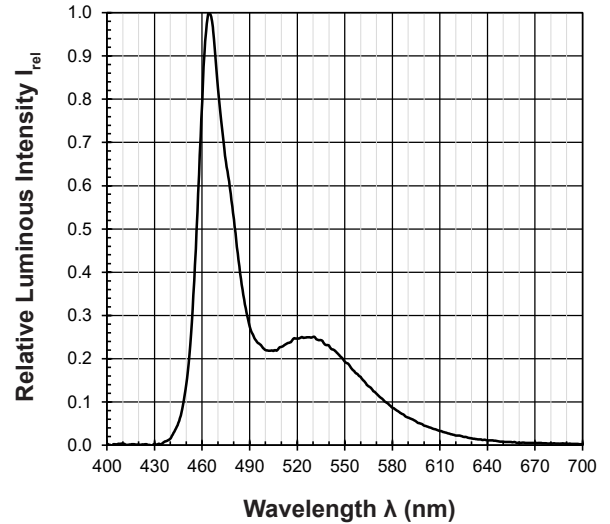

**Chromaticity Coordinate Shift Vs Forward Current** *Appx. 4.1*

$$\Delta Cx, \Delta Cy = f(I_F); T_j = 25^\circ C$$

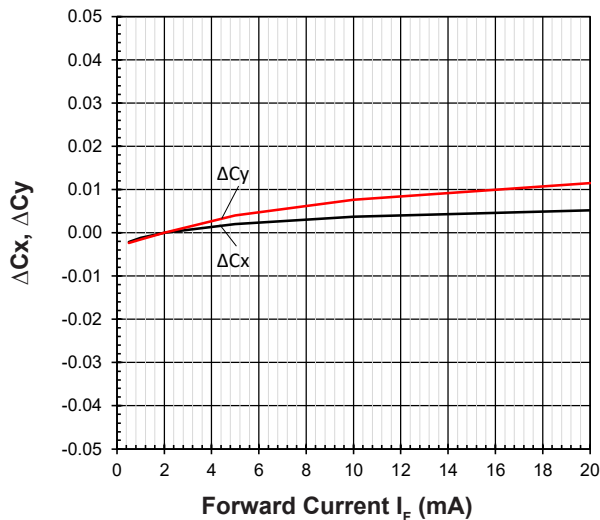

**Allowable Forward Current Vs Duty Ratio**

$$(T_s = 55^\circ C; t_p \le 100\mu s)$$

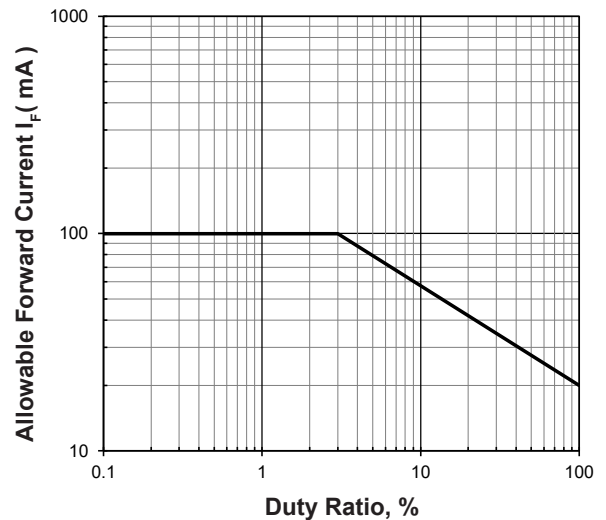

**Radiation Pattern** *Appx. 4.1*

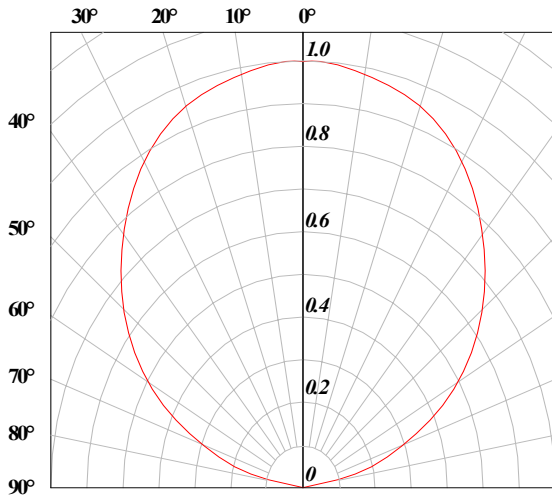

**Forward Voltage Vs Junction Temperature** *Appx. 4.1*

$$\Delta VF = VF - VF(25^\circ C) = f(T_j); I_F = 2mA$$

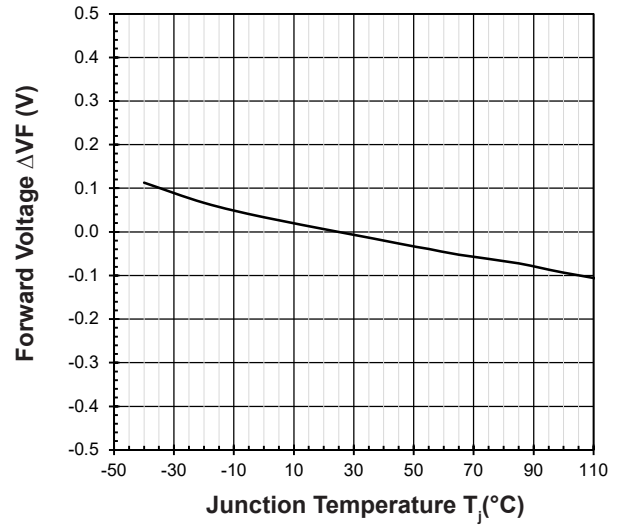

**Relative Luminous Intensity Vs Junction Temperature** *Appx. 4.1*

$$I_V / I_V(25^\circ C) = f(T_j); I_V = 2mA$$

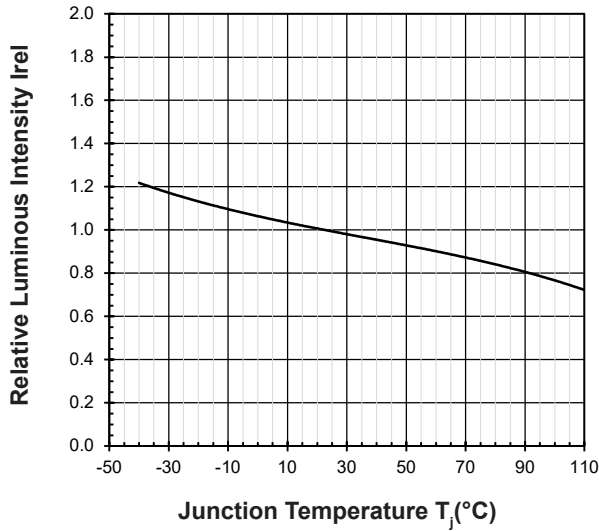

**Chromaticity Coordinate Shift Vs Junction Temperature** *Appx. 4.1*

$$\Delta C_x, \Delta C_y = f(T_j); I_F = 2mA$$

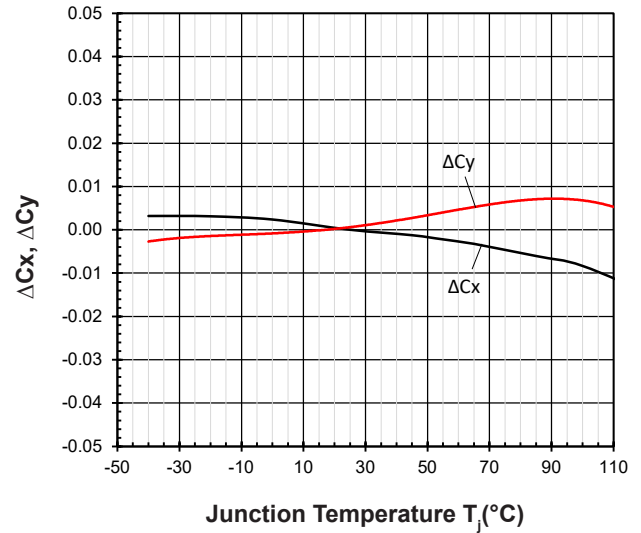

**Mini DomiLED • InGaN: DNZB-DJG-I2 Package Outlines** *Appx. 5.1*

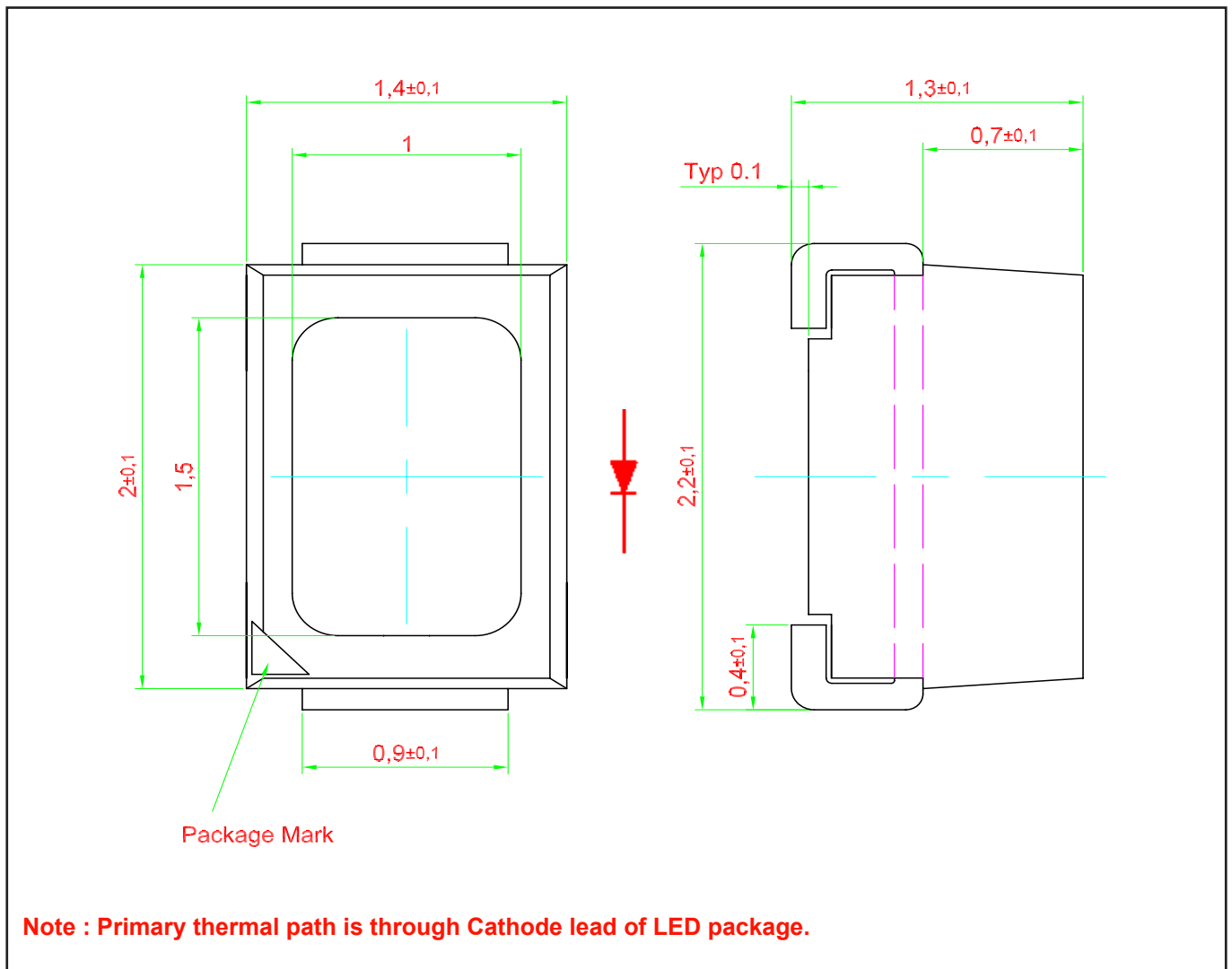

**Material**

	Material
Lead-frame	Cu Alloy With Ag Plating
Package	High Temperature Resistant Plastic
Encapsulant	Silicone Resin
Soldering Leads	Sn Plating

**Recommended Solder Pad** *Appx. 5.1*

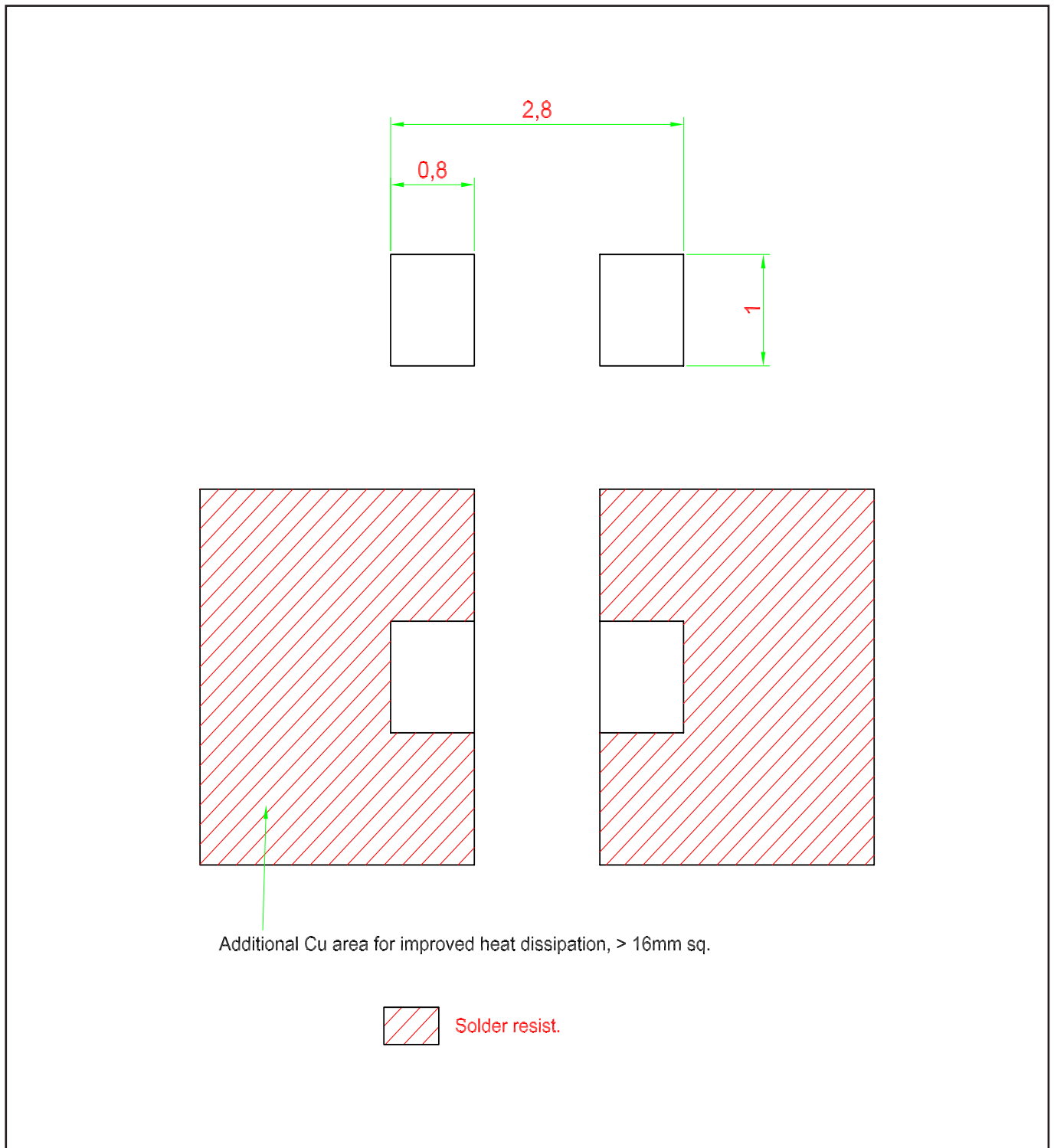

Taping and orientation Appx. 5.1

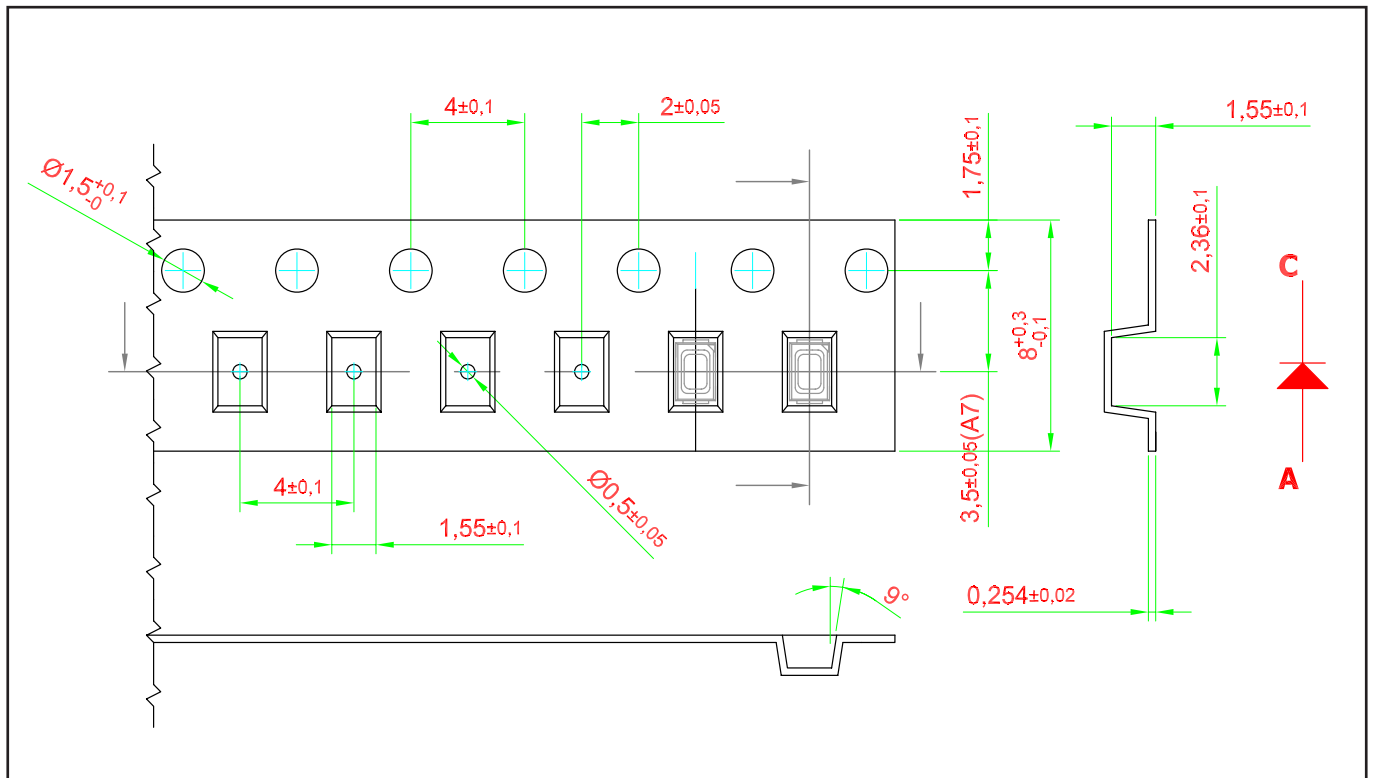

**Packaging Specification**

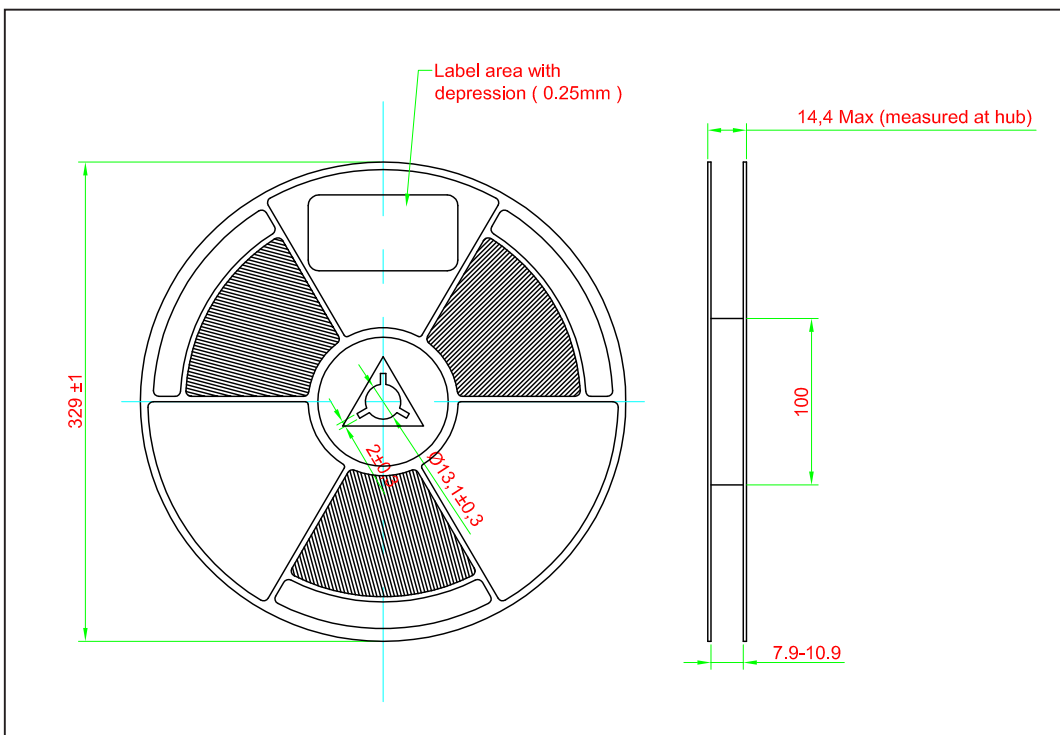
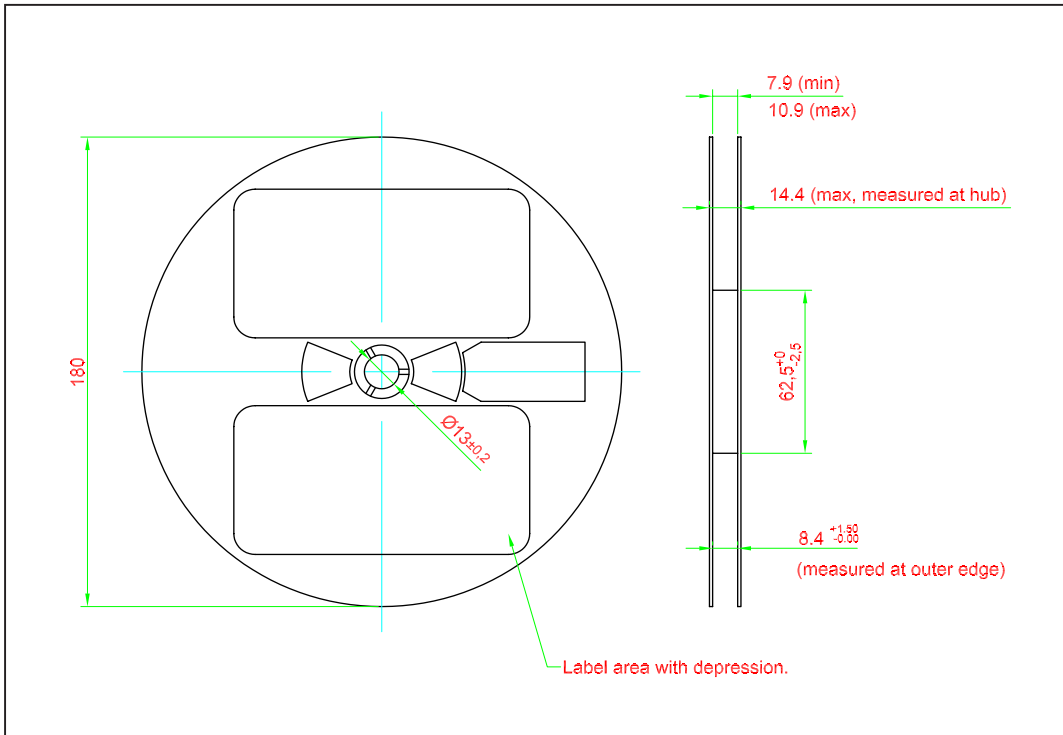

	Reel Diameter (mm)	Quantity (pcs)	*Ordering Number
Standard Packing	180	3000	DNZB-DJG-xxx-x-x
Optional Packing	329	10000	DNZB-DJG-xxx-x-x-J

Notes:

\* For ordering purpose only. Please consult sales and marketing for details.

**Packaging Specification**

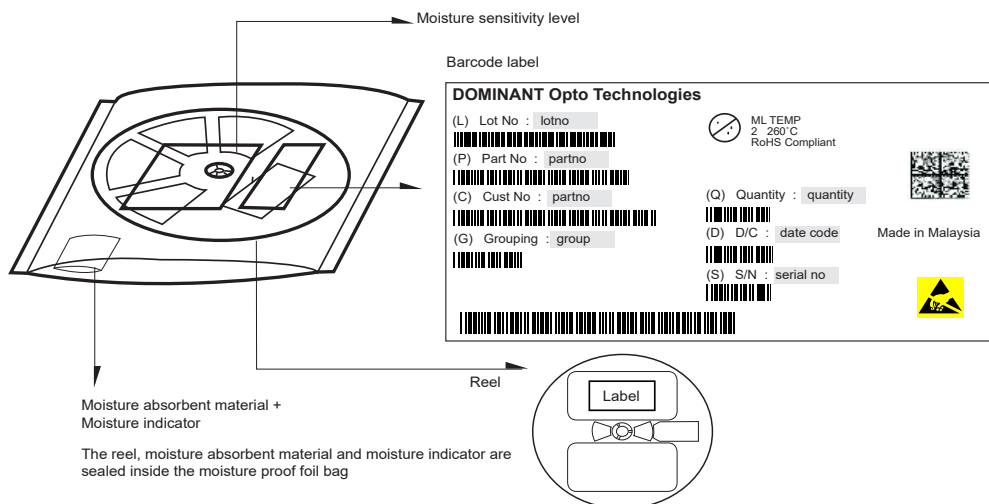

Quantity per bag (pcs)	Average 1pc Mini DomiLED (g)	1 completed bag (g)
3000	0.007	200 ± 10
10000	0.007	550 ± 10

## Recommended Pb-free Soldering Profile

Product complies to MSL Level 2 acc. to JEDEC J-STD-020E

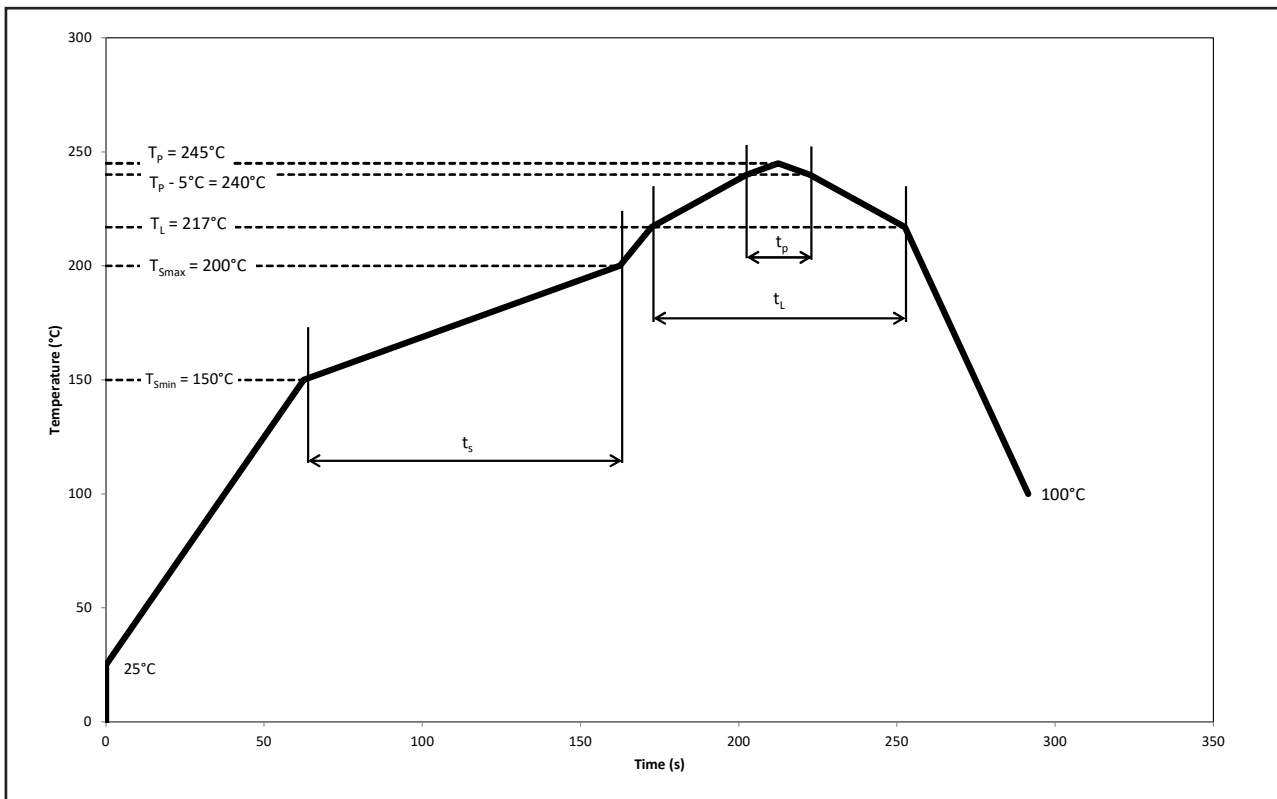

Profile Feature	Symbol	Pb-Free Assembly			Unit
		Min.	Recommended	Max.	
Ramp-up rate to preheat 25°C to $T_{smin}$	-	-	2	3	°C/s
Time $t_s$ $T_{smin}$ to $T_{smax}$	$t_s$	60	100	120	s
Ramp-up rate to peak $T_L$ to $T_p$	-	-	2	3	°C/s
Liquidous temperature	$T_L$	-	217	-	°C
Time above liquidous temperature	$t_L$	60	80	150	s
Peak temperature	$T_p$	-	245	260	°C
Time within 5°C of the specified peak temperature $T_p - 5°C$	$t_p$	10	20	30	s
Ramp-down rate $T_p$ to 100°C	-	-	3	6	°C/s
Time 25°C to $T_p$	-	-	-	480	s

## Appendix

### 1) **Brightness:**

- 1.1 Luminous intensity is measured at current pulse 25 ms(typ) with an internal reproducibility of  $\pm 8\%$  and an expanded uncertainty of  $\pm 11\%$  (according to GUM with a coverage factor of  $k=3$ ).
- 1.2 Luminous flux is measured at current pulse 25 ms(typ) with an internal reproducibility of  $\pm 8\%$  and an expanded uncertainty of  $\pm 11\%$  (according to GUM with a coverage factor of  $k=3$ ).
- 1.3 Radiant intensity is measured at current pulse 25 ms(typ) with an internal reproducibility of  $\pm 8\%$  and an expanded uncertainty of  $\pm 11\%$  (according to GUM with a coverage factor of  $k=3$ ).
- 1.4 Radiant flux is measured at current pulse 25 ms(typ) with an internal reproducibility of  $\pm 8\%$  and an expanded uncertainty of  $\pm 11\%$  (according to GUM with a coverage factor of  $k=3$ ).

### 2) **Color:**

- 2.1 Chromaticity coordinate groups are measured at current pulse 25 ms(typ) with an internal reproducibility of  $\pm 0.005$  and an expanded uncertainty of  $\pm 0.01$  (accordingly to GUM with a coverage factor of  $k=3$ ).
- 2.2 Dominant wavelength is measured at current pulse 25 ms(typ) with an internal reproducibility of  $\pm 0.5\text{nm}$  and an expanded uncertainty of  $\pm 1\text{nm}$  (accordingly to GUM with a coverage factor of  $k=3$ ).

### 3) **Voltage:**

- 3.1 Forward Voltage,  $V_f$  is measured when a current pulse of 8 ms(typ) with an internal reproducibility of  $\pm 0.05\text{V}$  and an expanded uncertainty of  $\pm 0.1\text{V}$  (accordingly to GUM with a coverage factor of  $k=3$ ).

### 4) **Typical Values:**

- 4.1 Due to the specific conditions of semiconductor devices' manufacturing processes, the provided typical data and calculated correlations of technical parameters should only be considered as statistical values. It is important to note that the actual parameters of individual devices may deviate from these typical data, calculated correlations or the typical characteristic line. Dominant reserves the right to update this typical data without prior notice, particularly in response to technical enhancements.

### 5) **Tolerance of Measure**

- 5.1 Unless otherwise noted in drawing, tolerances are specified with  $\pm 0.1$  and dimension are specified in mm.

### 6) **Reverse Voltage:**

- 6.1 Not designed for reverse operation. Continuous reverse voltage can cause migration and LED damage.

### 7) **Corrosion Robustness:**

- 7.1 Test conditions:  $40\text{ }^\circ\text{C}$  /  $90\%$  rh /  $15\text{ ppm H}_2\text{S}$  /  $336\text{ h}$ .  
= Stricter than IEC 60068-2-43 ( $\text{H}_2\text{S}$ ) [ $25\text{ }^\circ\text{C}$  /  $75\%$  rh /  $10\text{ ppm H}_2\text{S}$  /  $21\text{ days}$ ].

## Revision History

Page	Subjects	Date of Modification
-	Initial Release	26 Nov 2013
3	Update Color Bin Structure	11 Mar 2014
2, 3	Add Thermal Resistance Add Characteristics	24 Nov 2014
1, 8, 12, 14	Add Features Add Notes in Package Outline Typo Error on Material Update Package Specification Add Appendix	06 Feb 2017
10	Error on Taping and Orientation	06 Apr 2017
11, 12, 13, 14, 15	Update Packaging Specification Recommended Pb-free Soldering Profile Update Appendix	09 Apr 2021
1, 12	Update Product Photo Update Packaging Specification	08 Jan 2024
1, 2, 5, 6, 7	Update Features: AEC-Q101 to AEC-Q102 Update Test Condition for Peak Pulse Current Update Operating & Storage Temperature Add Vf Binning (Optional) Update Graph	06 Aug 2025

### NOTE

All the information contained in this document is considered to be reliable at the time of publishing. However, DOMINANT Opto Technologies does not assume any liability arising out of the application or use of any product described herein.

DOMINANT Opto Technologies reserves the right to make changes to any products in order to improve reliability, function or design.

DOMINANT Opto Technologies products are not authorized for use as critical components in life support devices or systems without the express written approval from the Managing Director of DOMINANT Opto Technologies.

Dispose of product is in accordance with local, regional, national and international regulations.

## About Us

DOMINANT Opto Technologies is a dynamic company that is amongst the world's leading automotive LED manufacturers. With an extensive industry experience and relentless pursuit of innovation, DOMINANT's state-of-art manufacturing and development capabilities have become a trusted and reliable brand across the globe. More information about DOMINANT Opto Technologies, an IATF 16949 and ISO 14001 certified company, can be found under <http://www.dominant-semi.com>.

### **Please contact us for more information:**

DOMINANT Opto Technologies Sdn. Bhd.  
Lot 6, Batu Berendam, FTZ Phase III, 75350 Melaka, Malaysia  
Tel: (606) 283 3566 Fax: (606) 283 0566  
E-mail: [sales@dominant-semi.com](mailto:sales@dominant-semi.com)

---