

Mini DomiLED

Synonymous with function and performance, the Mini DomiLED series is perfectly suited for a variety of cross-industrial applications due to its small package outline, durability and superior brightness.

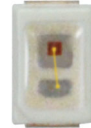

Features:

- > High brightness surface mount LED.
- > 120° viewing angle.
- > Small package outline (LxWxH) of 2.0 x 1.4 x 1.3mm.
- > Qualified according to JEDEC moisture sensitivity Level 2.
- > Compatible to IR reflow soldering.
- > Environmental friendly; RoHS compliance.
- > Compliance to automotive standard; AEC-Q102.



Applications:

- > Automotive: interior applications, eg: switches, climate control system, dashboard, etc.



Optical Characteristics at Tj=25°C

Part Number	Color	Viewing Angle°	Luminous Intensity @ IF = 20mA IV (mcd) <i>Appx. 1.1</i>		
			Min.	Typ.	Max.
DLS-GJS-U5V6-1	Super red, 632nm	120	450.0	715.0	970.0
DLA-GJS-V6W6-2	Amber, 615nm	120	820.0	1300.0	1500.0
DLA-GJS-U7V7-4	Amber, 624nm	120	610.0	820.0	1125.0
DLO-GJS-V6W6-1	Orange, 605nm	120	820.0	1300.0	1500.0
DLY-GJS-V5W5-1	Yellow, 590nm	120	715.0	1125.0	1300.0

Electrical Characteristics at Tj=25°C

Part Number	Vf @ If = 20mA <i>Appx. 3.1</i>			Vr @ Ir = 10uA
	Min. (V)	Typ. (V)	Max. (V)	Min. (V)
DLx-GJS	1.8	2.1	2.4	12

Absolute Maximum Ratings

	Maximum Value	Unit
DC forward current	50	mA
Peak pulse current; (Ts = 55°C, tp ≤ 100µs, Duty cycle = 0.03)	210	mA
Reverse voltage <i>Appx. 6.1</i>	12	V
ESD threshold (HBM)	2000	V
LED junction temperature	125	°C
Operating temperature	-40 ... +105	°C
Storage temperature	-40 ... +105	°C
Power dissipation (at room temperature)	120	mW
Thermal resistance (Rated current = 20mA, Ts = 25 °C) - Junction / solder point, Rth JS	175	K/W

Wavelength Grouping at Tj=25°C

Color	Group	Wavelength distribution (nm) <small>Appx. 2.2</small>
DLS; Super-red	Full	627 - 637
DLA; Amber	Full	612 - 627
	W	612 - 616
	X	616 - 620
	Y	620 - 624
	Z	624 - 627
DLO; Orange	Full	600 - 609
	W	600 - 603
	X	603 - 606
	Y	606 - 609
DLY; Yellow	Full	586 - 595
	X	586 - 589
	Y	589 - 592
	Z	592 - 595

Luminous Intensity Group at Tj=25°C

Brightness Group	Luminous Intensity <small>Appx. 1.1</small> IV (mcd)
U5	450.0 ... 520.0
U6	520.0 ... 610.0
U7	610.0 ... 715.0
V5	715.0 ... 820.0
V6	820.0 ... 970.0
V7	970.0 ... 1125.0
W5	1125.0 ... 1300.0
W6	1300.0 ... 1500.0

Vf Binning (Optional)

Vf @ If = 20mA	Forward Voltage (V) <i>Appx. 3.1</i>
V03	1.80 ... 1.95
V04	1.95 ... 2.10
V05	2.10 ... 2.25
V06	2.25 ... 2.40

Please consult sales and marketing for special part number to incorporate Vf binning.

Relative Luminous Intensity Vs Forward Current *Appx. 4.1*

$$I_{\sqrt{I_V}}(20\text{mA}) = f(I_F); T_j = 25^\circ\text{C}$$

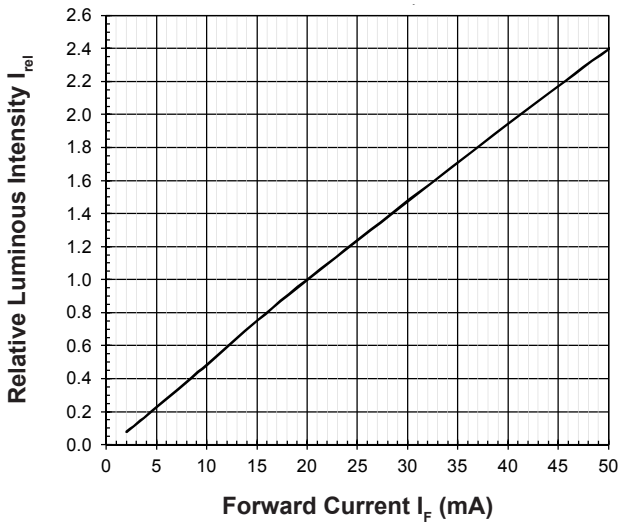

Forward Current Vs Forward Voltage *Appx. 4.1*

$$I_F = f(V_F); T_j = 25^\circ\text{C}$$

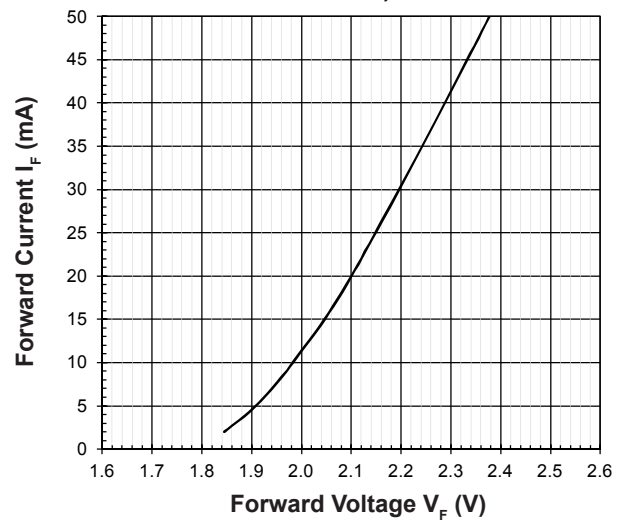

Maximum Current Vs Temperature

$$I_F = f(T)$$

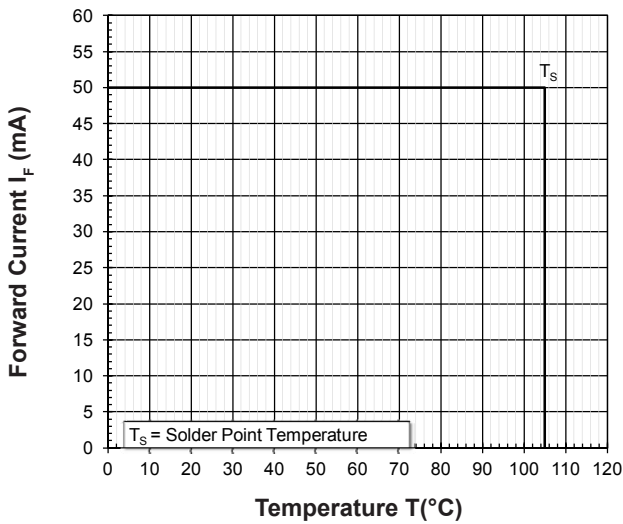

Relative Spectral Emission *Appx. 4.1*

$$I_{rel} = f(\lambda); T_j = 25^\circ\text{C}; I_F = 20\text{mA}$$

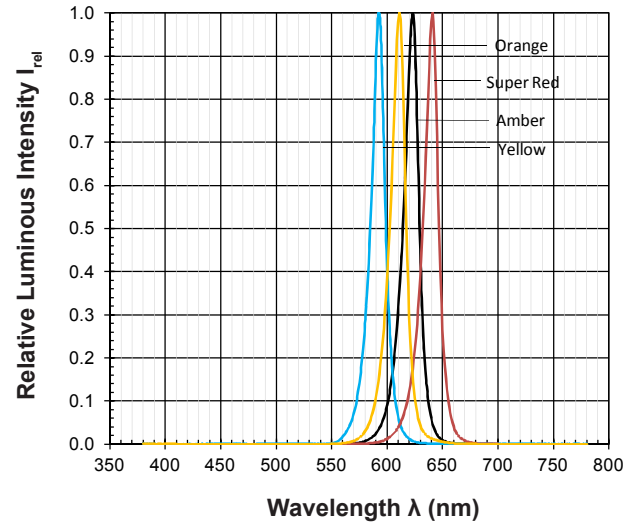

Allowable Forward Current Vs Duty Ratio

$$(T_s = 55^\circ\text{C}; t_p \leq 100\mu\text{s})$$



Radiation Pattern *Appx. 4.1*

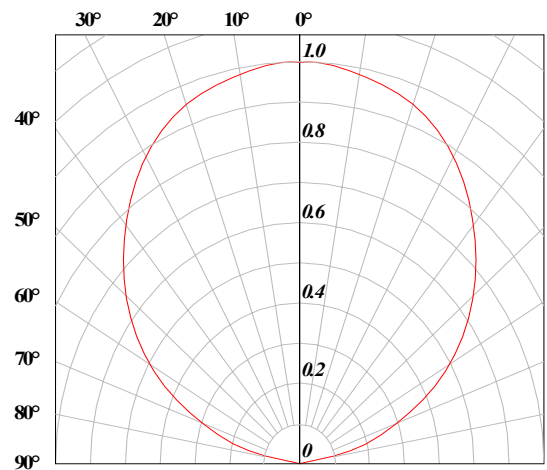

Forward Voltage Vs Junction Temperature *Appx. 4.1*

$\Delta V_F = V_F - V_F(25^\circ\text{C}) = f(T_j); I_F = 20\text{mA}$

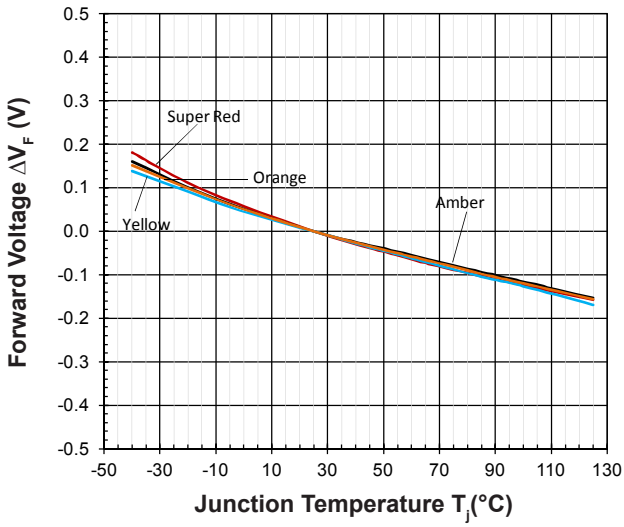

Relative Luminous Intensity Vs Junction Temperature *Appx. 4.1*

$I_V/I_V(25^\circ\text{C}) = f(T_j); I_F = 20\text{mA}$

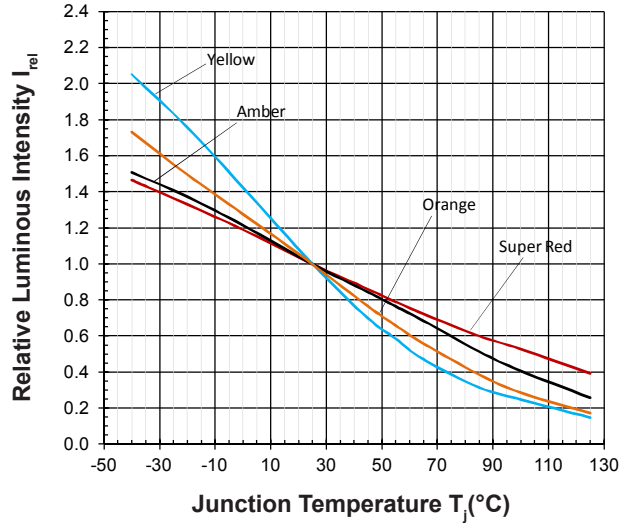

Wavelength Vs Junction Temperature *Appx. 4.1*

$\Delta \lambda_{\text{dom}} = \lambda_{\text{dom}} - \lambda_{\text{dom}}(25^\circ\text{C}) = f(T_j); I_F = 20\text{mA}$

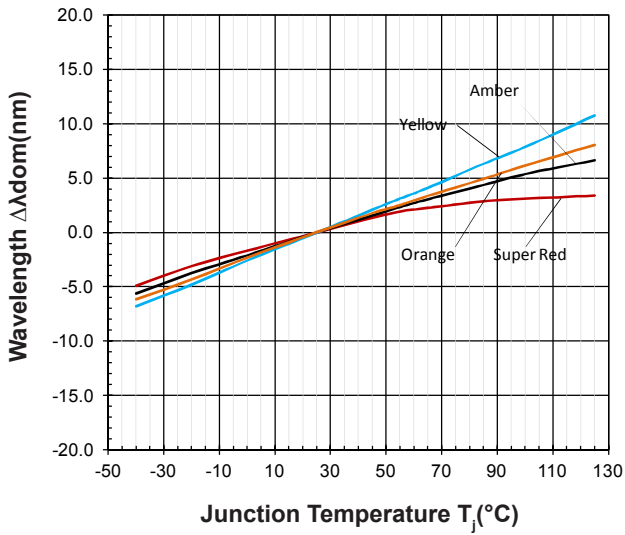

Mini DomiLED • AllnGaP : DLx-GJS Package Outlines *Appx. 5.1*

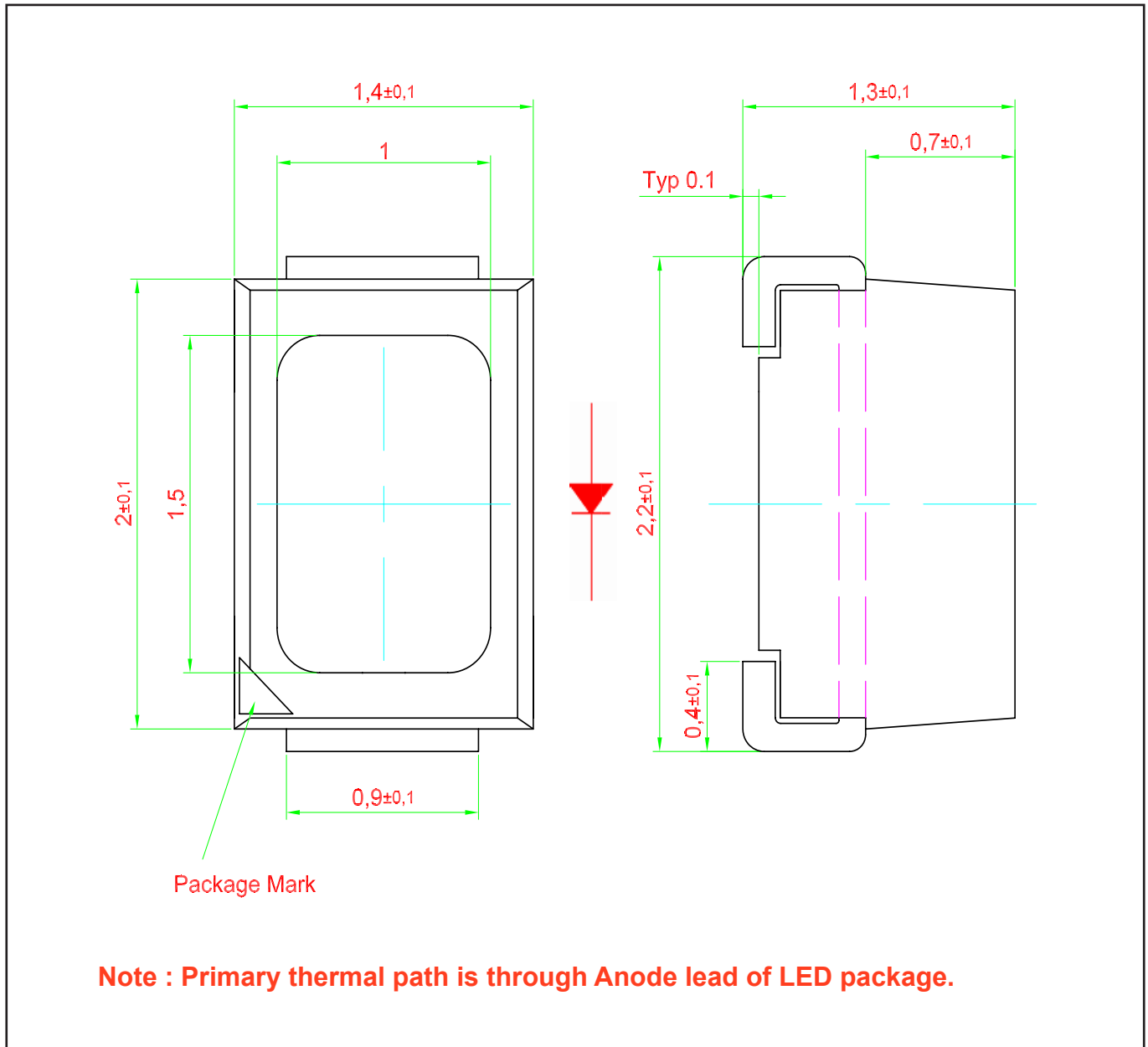

Material

Material	
Lead-frame	Cu Alloy With Ag Plating
Package	High Temperature Resistant Plastic
Encapsulant	Epoxy Resin
Soldering Leads	Sn Plating

Recommended Solder Pad Appx. 5.1

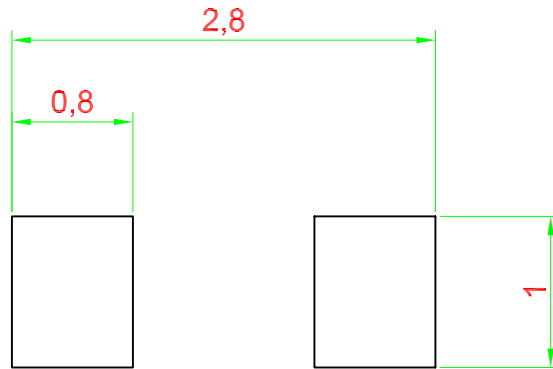

Improved Design For Better Heat Dissipation

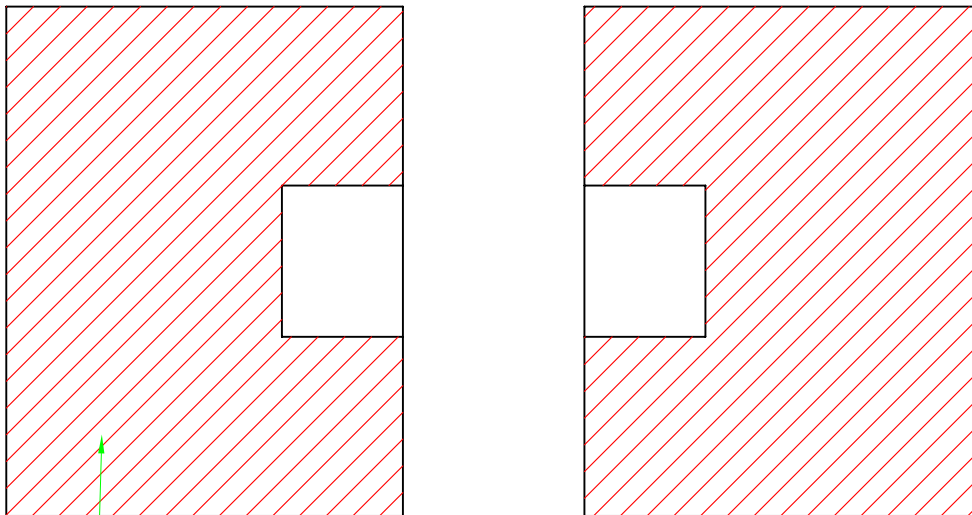

Additional Cu area for improved heat dissipation, > 16mm sq.

 Solder resist.

Taping and orientation *Appx. 5.1*

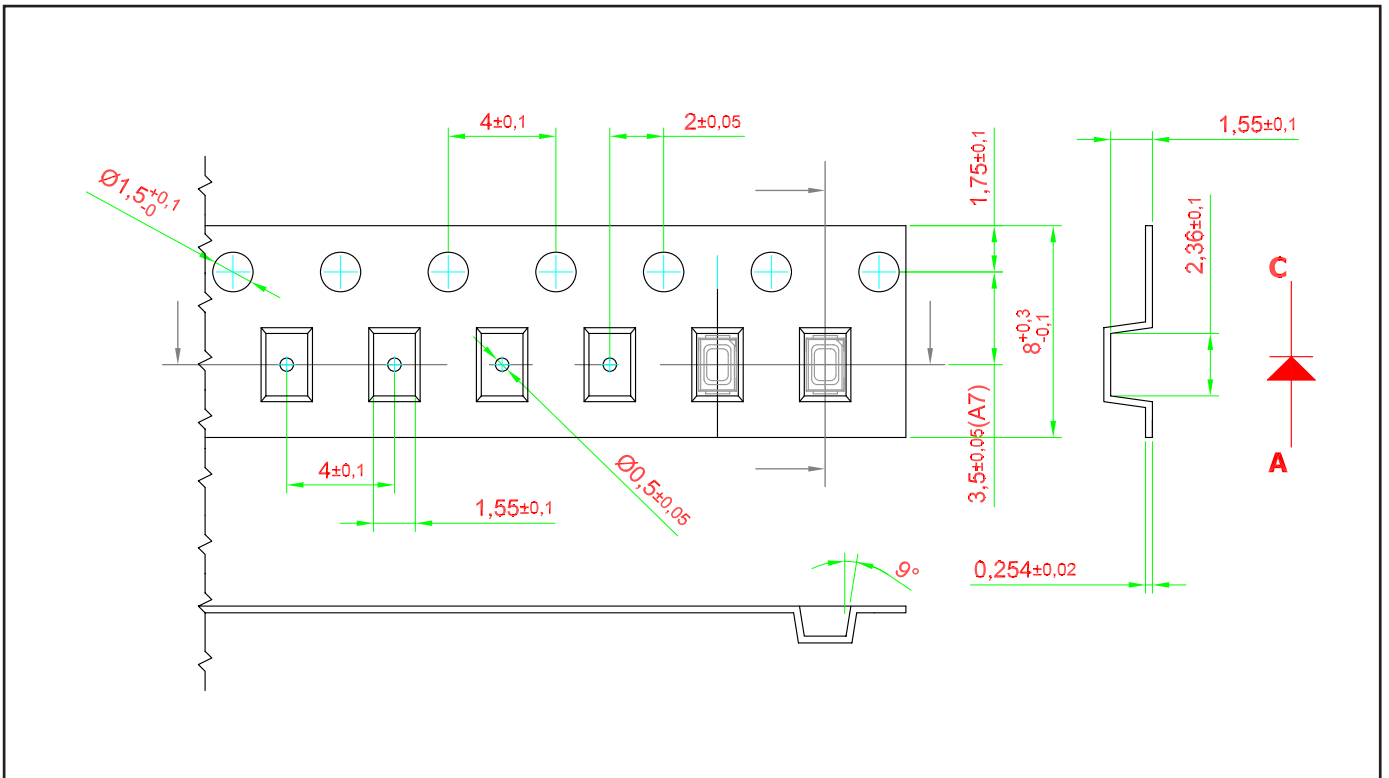

Packaging Specification

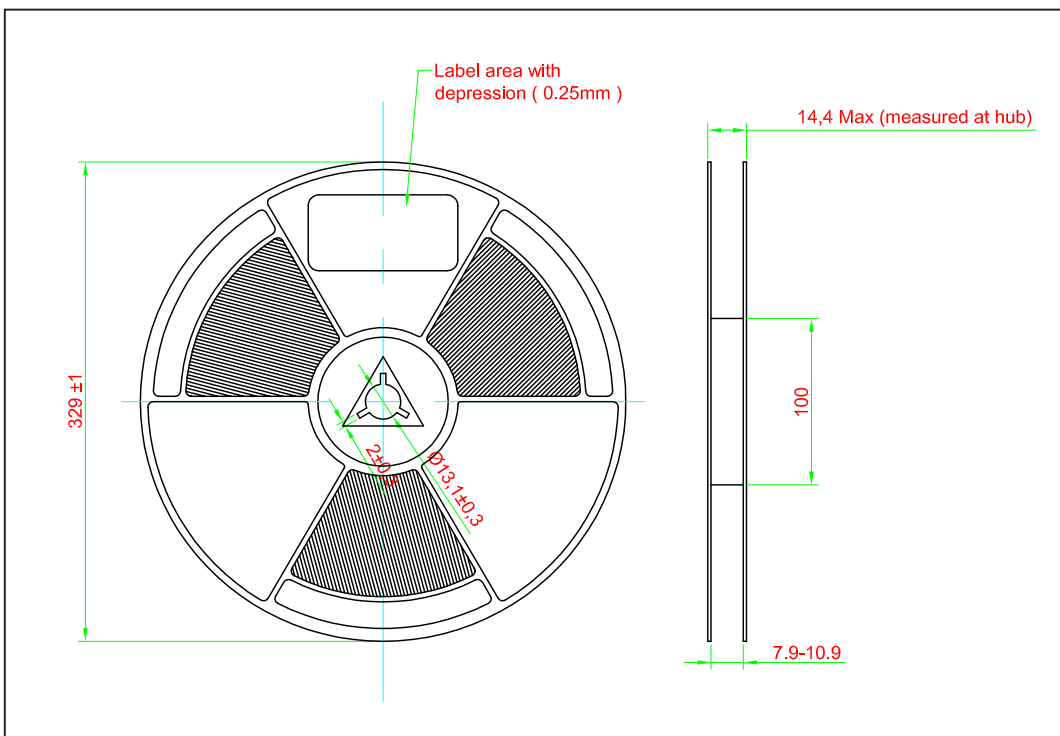
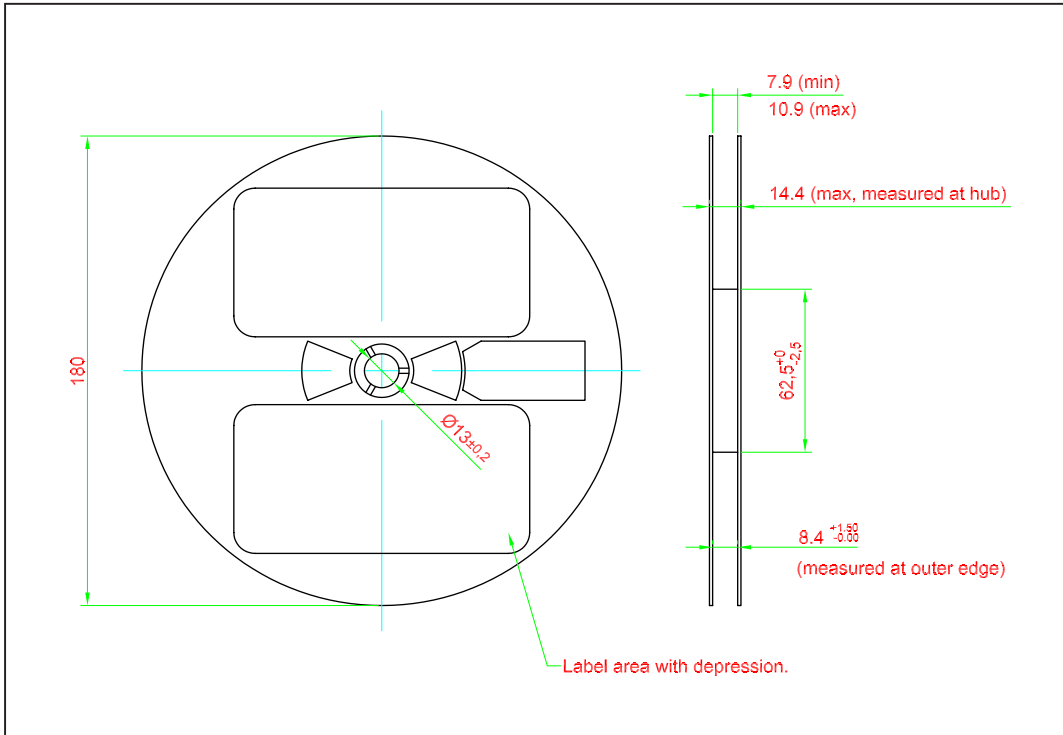

	Reel Diameter (mm)	Quantity (pcs)	*Ordering Number
Standard Packing	180	3000	DLx-GJS-xxx-x
Optional Packing	329	10000	DLx-GJS-xxx-x-J

Notes:

* For ordering purpose only. Please consult sales and marketing for details.

Packaging Specification

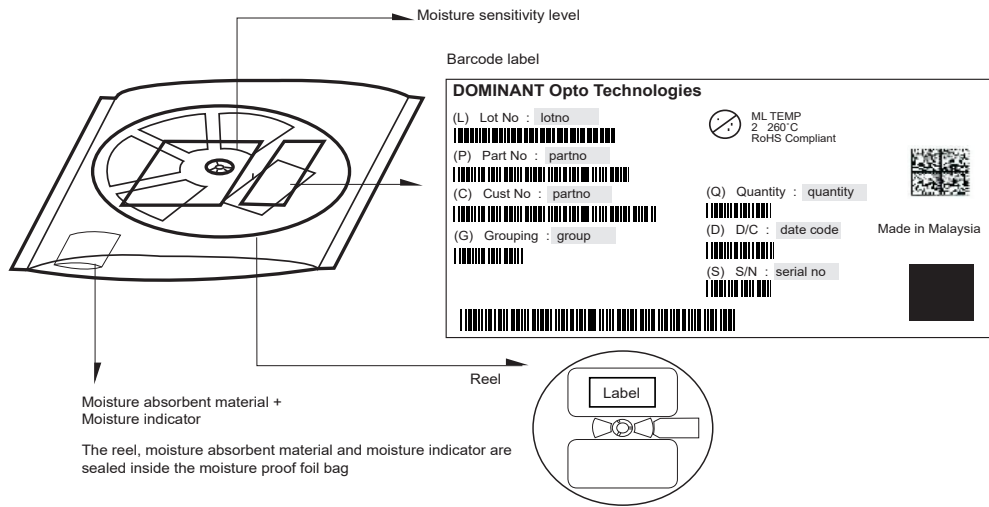

Quantity per bag (pcs)	Average 1pc Mini DomiLED (g)	1 completed bag (g)
3000	0.007	200 ± 10
10000	0.007	550 ± 10

Recommended Pb-free Soldering Profile

Product complies to MSL Level 2 acc. to JEDEC J-STD-020E

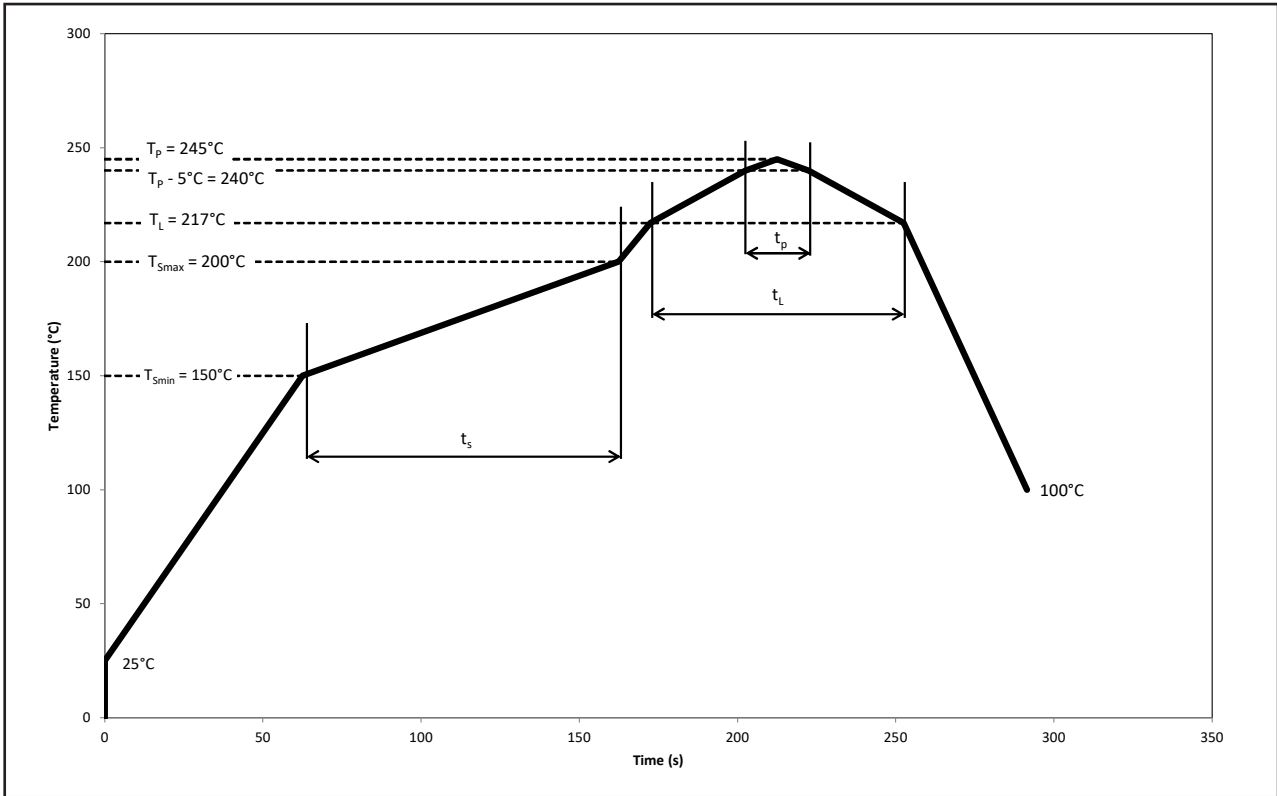

Profile Feature	Symbol	Pb-Free Assembly			Unit
		Min.	Recommended	Max.	
Ramp-up rate to preheat 25°C to T_{smin}	-	-	2	3	°C/s
Time t_s T_{smin} to T_{smax}	t_s	60	100	120	s
Ramp-up rate to peak T_L to T_p	-	-	2	3	°C/s
Liquidous temperature	T_L	-	217	-	°C
Time above liquidous temperature	t_L	60	80	150	s
Peak temperature	T_p	-	245	260	°C
Time within 5°C of the specified peak temperature $T_p - 5°C$	t_p	10	20	30	s
Ramp-down rate T_p to 100°C	-	-	3	6	°C/s
Time 25°C to T_p	-	-	-	480	s

Appendix

1) **Brightness:**

- 1.1 Luminous intensity is measured at current pulse 25 ms(typ) with an internal reproducibility of $\pm 8\%$ and an expanded uncertainty of $\pm 11\%$ (according to GUM with a coverage factor of $k=3$).
- 1.2 Luminous flux is measured at current pulse 25 ms(typ) with an internal reproducibility of $\pm 8\%$ and an expanded uncertainty of $\pm 11\%$ (according to GUM with a coverage factor of $k=3$).
- 1.3 Radiant intensity is measured at current pulse 25 ms(typ) with an internal reproducibility of $\pm 8\%$ and an expanded uncertainty of $\pm 11\%$ (according to GUM with a coverage factor of $k=3$).
- 1.4 Radiant flux is measured at current pulse 25 ms(typ) with an internal reproducibility of $\pm 8\%$ and an expanded uncertainty of $\pm 11\%$ (according to GUM with a coverage factor of $k=3$).

2) **Color:**

- 2.1 Chromaticity coordinate groups are measured at current pulse 25 ms(typ) with an internal reproducibility of ± 0.005 and an expanded uncertainty of ± 0.01 (accordingly to GUM with a coverage factor of $k=3$).
- 2.2 Dominant wavelength is measured at current pulse 25 ms(typ) with an internal reproducibility of $\pm 0.5\text{nm}$ and an expanded uncertainty of $\pm 1\text{nm}$ (accordingly to GUM with a coverage factor of $k=3$).

3) **Voltage:**

- 3.1 Forward Voltage, V_f is measured when a current pulse of 8 ms(typ) with an internal reproducibility of $\pm 0.05\text{V}$ and an expanded uncertainty of $\pm 0.1\text{V}$ (accordingly to GUM with a coverage factor of $k=3$).

4) **Typical Values:**

- 4.1 Due to the specific conditions of semiconductor devices' manufacturing processes, the provided typical data and calculated correlations of technical parameters should only be considered as statistical values. It is important to note that the actual parameters of individual devices may deviate from these typical data, calculated correlations or the typical characteristic line. Dominant reserves the right to update this typical data without prior notice, particularly in response to technical enhancements.

5) **Tolerance of Measure**

- 5.1 Unless otherwise noted in drawing, tolerances are specified with ± 0.1 and dimension are specified in mm.

6) **Reverse Voltage:**

- 6.1 Not designed for reverse operation. Continuous reverse voltage can cause migration and LED damage.

Revision History

Page	Subjects	Date of Modification
-	Initial Release	06 Jan 2021
11	Update Packaging Specification	03 Feb 2025

NOTE

All the information contained in this document is considered to be reliable at the time of publishing. However, DOMINANT Opto Technologies does not assume any liability arising out of the application or use of any product described herein.

DOMINANT Opto Technologies reserves the right to make changes to any products in order to improve reliability, function or design.

DOMINANT Opto Technologies products are not authorized for use as critical components in life support devices or systems without the express written approval from the Managing Director of DOMINANT Opto Technologies.

Dispose of product is in accordance with local, regional, national and international regulations.

About Us

DOMINANT Opto Technologies is a dynamic company that is amongst the world's leading automotive LED manufacturers. With an extensive industry experience and relentless pursuit of innovation, DOMINANT's state-of-art manufacturing and development capabilities have become a trusted and reliable brand across the globe. More information about DOMINANT Opto Technologies, an IATF 16949 and ISO 14001 certified company, can be found under <http://www.dominant-semi.com>.

Please contact us for more information:

DOMINANT Opto Technologies Sdn. Bhd.
Lot 6, Batu Berendam, FTZ Phase III, 75350 Melaka, Malaysia
Tel: (606) 283 3566 Fax: (606) 283 0566
E-mail: sales@dominant-semi.com