

### Mini DomiLED

With the intense colors that seem to glow with energy and its significant brightness, Mini DomiLED white LED is a highly reliable design device. Its dynamic nature makes it perfect choice for lighthing applications, office and home applications and standard industrial applications.

### Features:

- > High brightness surface mount LED.
- > Based on InGaN technology.
- > 120° viewing angle.
- > Small package outline (LxWxH) of 2.0 x 1.8 x 1.3mm.
- > Qualified according to JEDEC moisture sensitivity Level 2.
- > Compatible to both IR reflow soldering.
- > Environmental friendly; RoHS compliance.
- > Superior Corrosion Resistance.
- > Compliance to automotive standard; AEC-Q102.

### Applications:

- > Automotive: interior applications, eg: switches, climate control system, dashboard, etc.



**Optical Characteristics at Tj=25°C**

Part Number	Color	Viewing Angle°	Luminous Intensity @ IF = 30mA IV (mcd) <i>Appx. 1.1</i>		
			Min.	Typ.	Max.
DFZY-HZKG-WX1-5E	InGaN Yellow	120	1125.0	1800.0	2240.0
DFZY-HZKG-W2X1-5D	InGaN Yellow	120	1400.0	1800.0	2240.0

**Electrical Characteristics at Tj=25°C**

Part Number	Vf @ If = 30 mA <i>Appx. 3.1</i>		
	Min. (V)	Typ. (V)	Max. (V)
DFZY-HZKG	2.8	3.1	3.4

**Absolute Maximum Ratings**

	Maximum Value	Unit
DC forward current	50	mA
Peak pulse current; (Ts=55°C, tp<=100µs , Duty cycle=0.03)	100	mA
Reverse voltage <i>Appx. 6.1</i>	Not for reverse bias	V
ESD threshold (HBM)	8000	V
LED junction temperature	125	°C
Operating temperature	-40 ... +115	°C
Storage temperature	-40 ... +125	°C
Power dissipation (at room temperature)	170	mW
Thermal resistance (Rated current = 30mA, Ts = 25 °C)		
- Real Thermal Resistance		
Junction / solder point, Rth JS	130	K/W

**DFZY, Color Grouping** *Appx. 2.1*

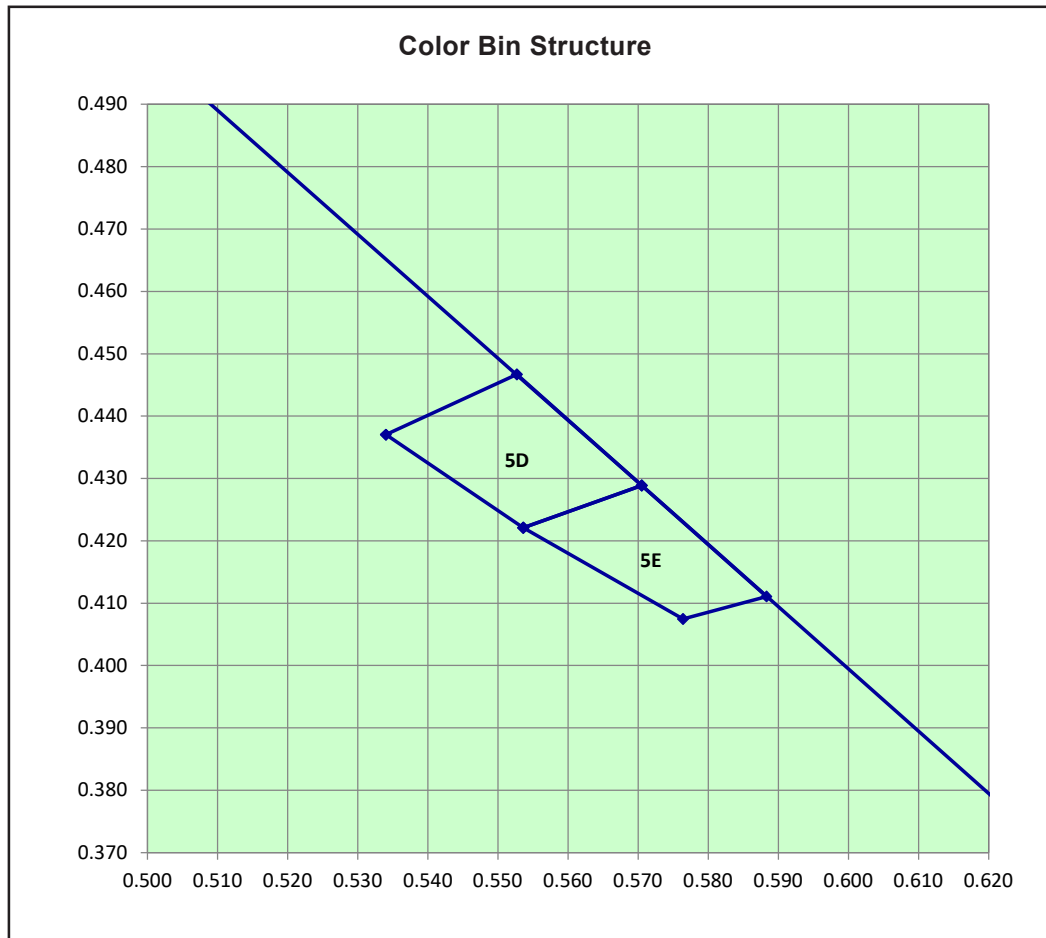

Bin		1	2	3	4
5E	Cx	0.5536	0.5705	0.5883	0.5764
	Cy	0.4221	0.4289	0.4111	0.4075
5D	Cx	0.5340	0.5527	0.5705	0.5536
	Cy	0.4370	0.4467	0.4289	0.4221

InGaN wavelength is very sensitive to drive current. Operating at lower current is not recommended and may yield unpredictable performance. Current pulsing should be used for dimming purposes.

### Luminous Intensity Group at T<sub>j</sub>=25°C

Brightness Group	Luminous Intensity <small>Appx. 1.1</small> IV (mcd)
W1	1125.0 ... 1400.0
W2	1400.0 ... 1800.0
X1	1800.0 ... 2240.0

### V<sub>f</sub> Bining (Optional)

V <sub>f</sub> @ I <sub>f</sub> = 30mA	Forward Voltage (V) <small>Appx. 3.1</small>
VR7	2.80 ... 3.10
VR8	3.10 ... 3.40

Please consult sales and marketing for special part number to incorporate V<sub>f</sub> binning.

**Relative Luminous Intensity Vs Forward Current**

$I_v/I_v(30\text{mA}) = f(I_F); T_j = 25^\circ\text{C}$

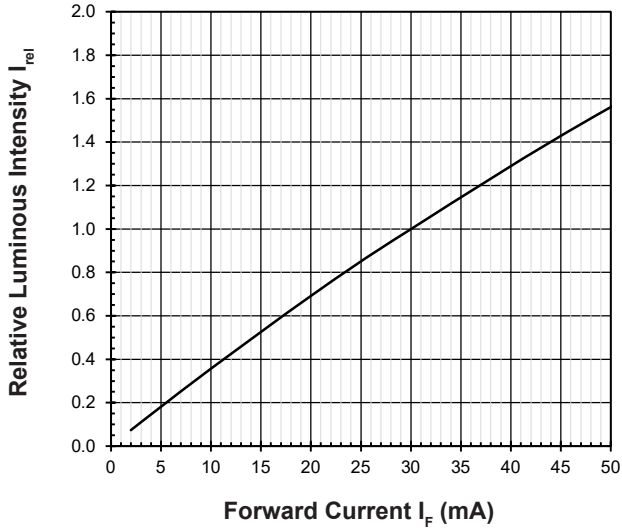

**Forward Current Vs Forward Voltage**

$I_F = f(V_F); T_j = 25^\circ\text{C}$

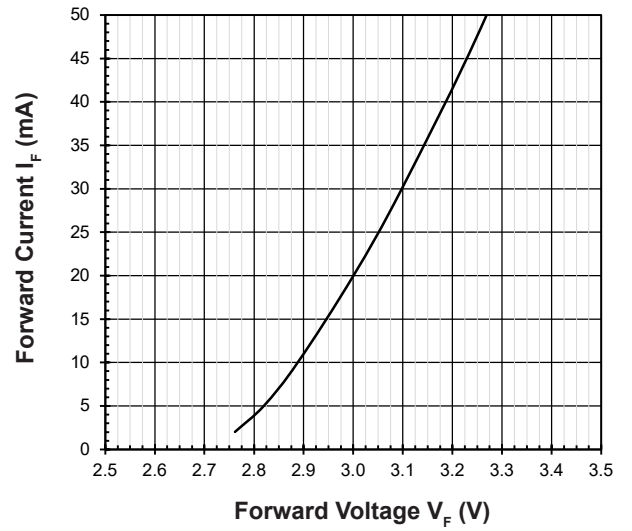

**Maximum Current Vs Temperature**

$I_F = f(T)$

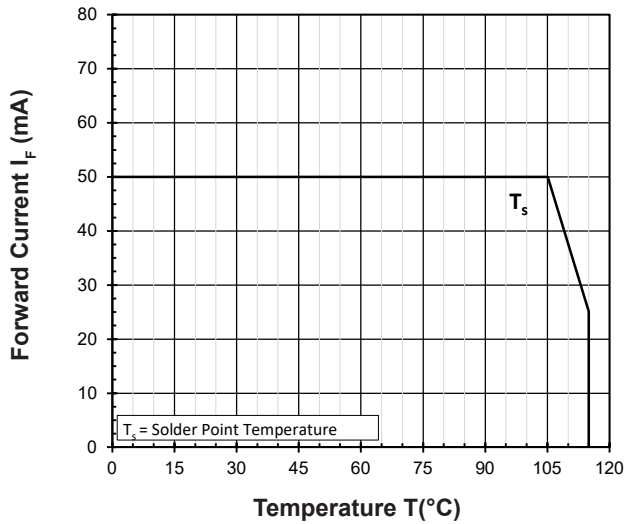

**Relative Spectral Emission**

$I_{rel} = f(\lambda); T_j = 25^\circ\text{C}; I_F = 30\text{mA}$

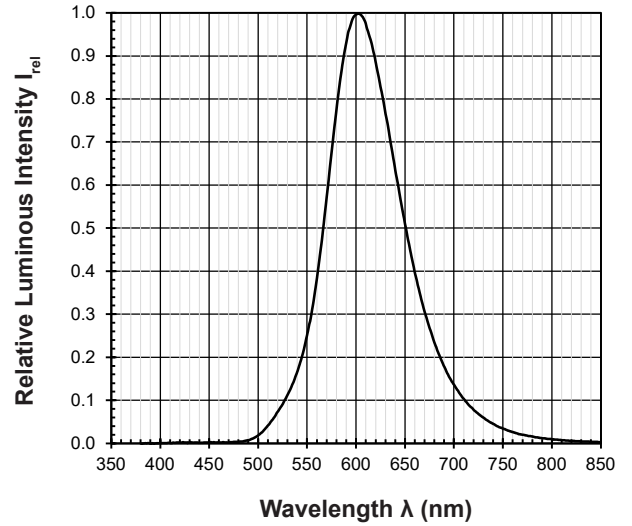

**Chromaticity Coordinate Shift Vs Forward Current**

$\Delta Cx, \Delta Cy = f(I_F); T_j = 25^\circ\text{C}$

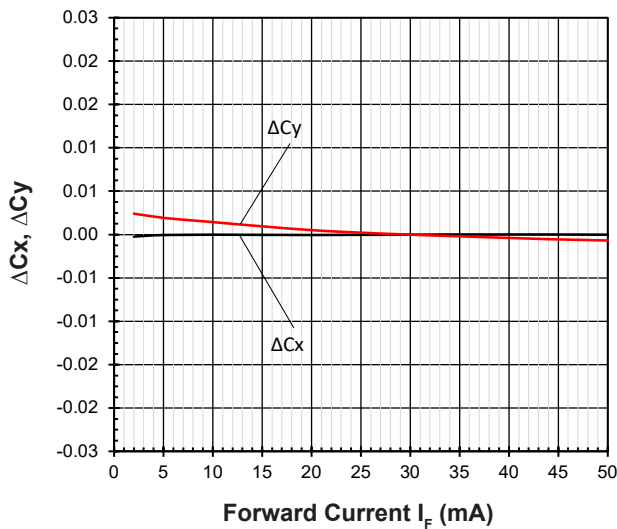

**Allowable Forward Current Vs Duty Ratio**

$(T_s = 55^\circ\text{C}; t_p \leq 100\mu\text{s})$

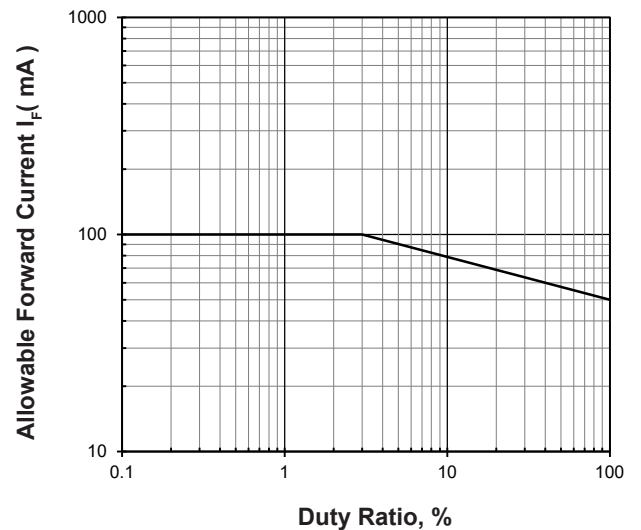

**Radiation Pattern**

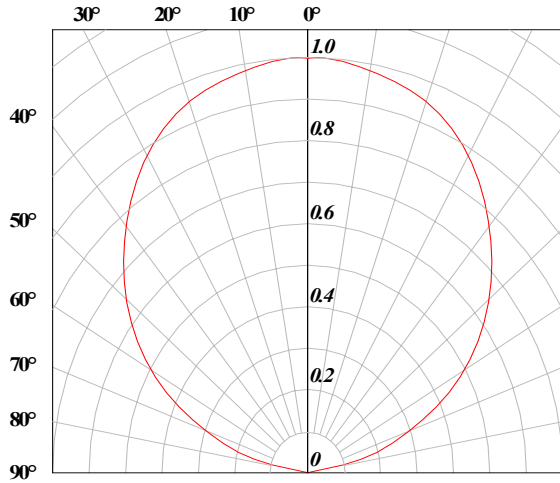

**Forward Voltage Vs Junction Temperature**

$$\Delta V_F = V_F - V_F(25^\circ\text{C}) = f(T_j); I_F = 30\text{mA}$$

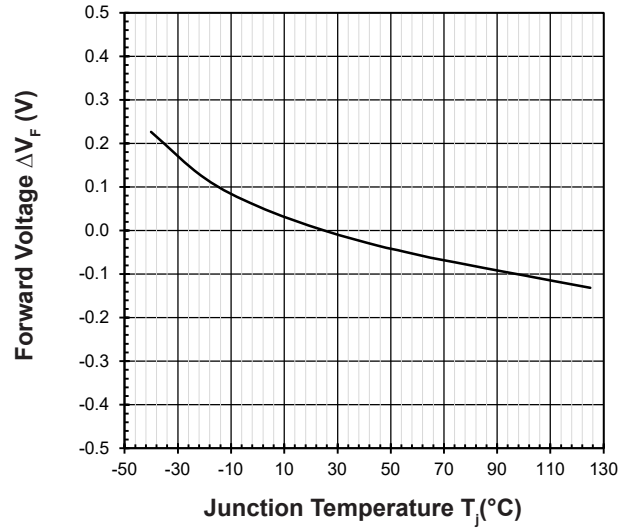

**Relative Luminous Intensity Vs Junction Temperature**

$$I_v/I_v(25^\circ\text{C}) = f(T_j); I_F = 30\text{mA}$$

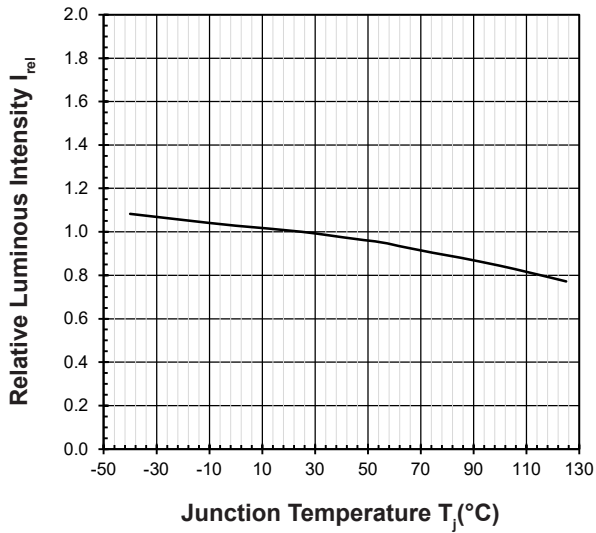

**Chromaticity Coordinate Shift Vs Junction Temperature**

$$\Delta Cx, \Delta Cy = f(T_j); I_F = 30\text{mA}$$

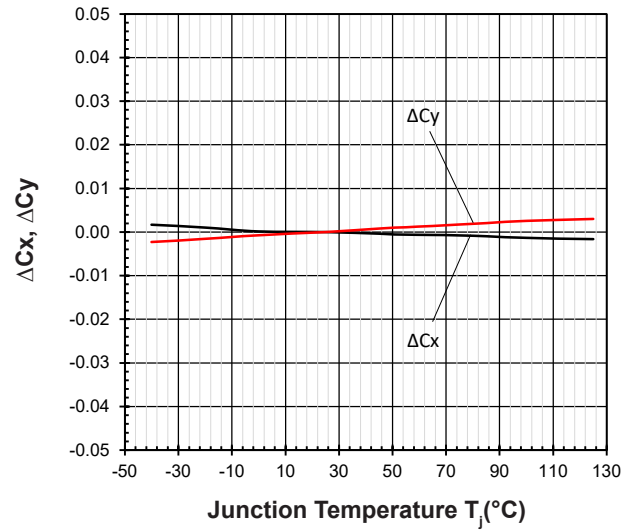

**MiniPlus DomiLED • InGaN : DFZY-HZKG Package Outlines**

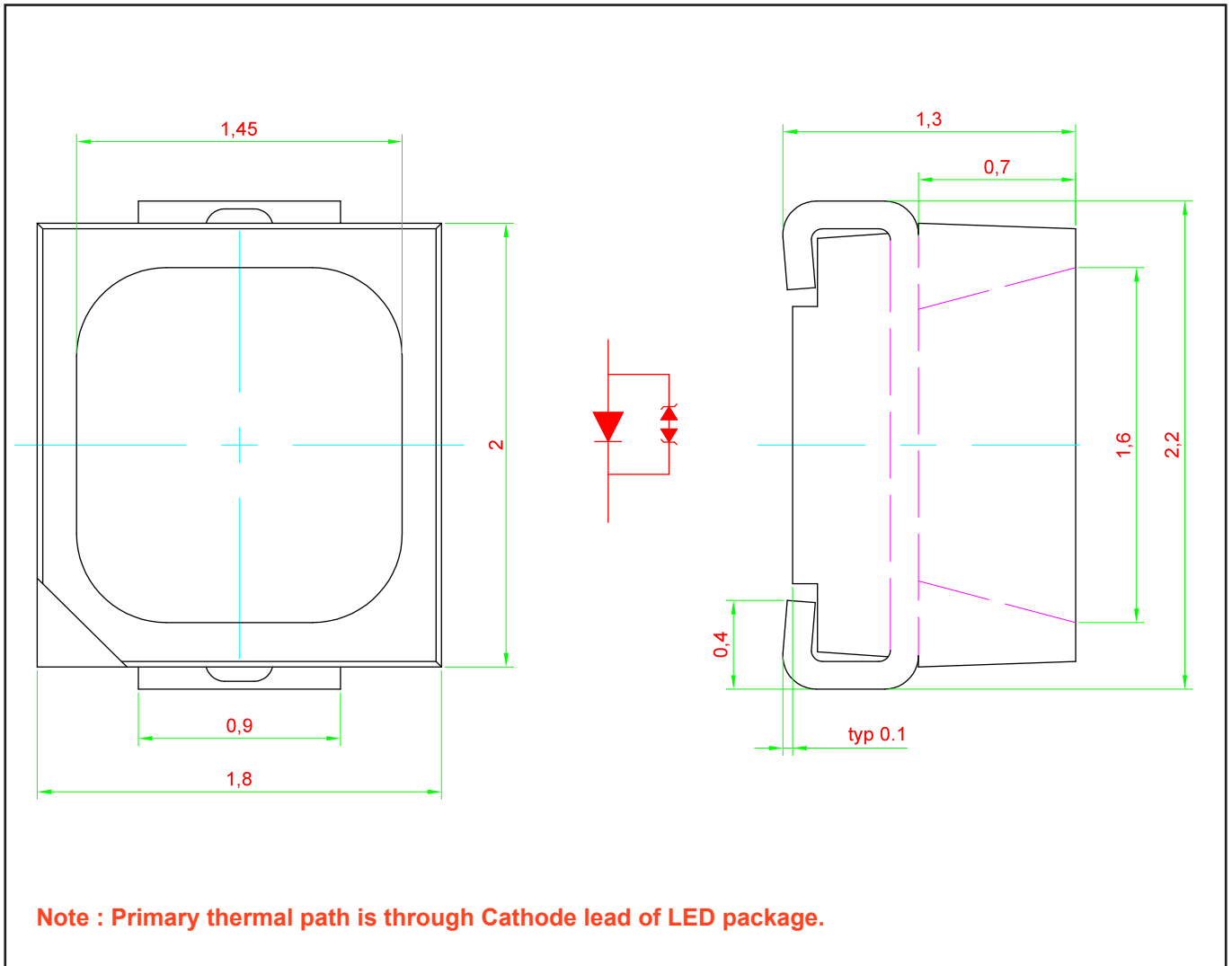

**Material**

	Material
Lead-frame	Cu Alloy With Au Plating
Package	High Temperature Resistant Plastic
Encapsulant	Silicone Resin
Soldering Leads	Au Plating

**Recommended Solder Pad**

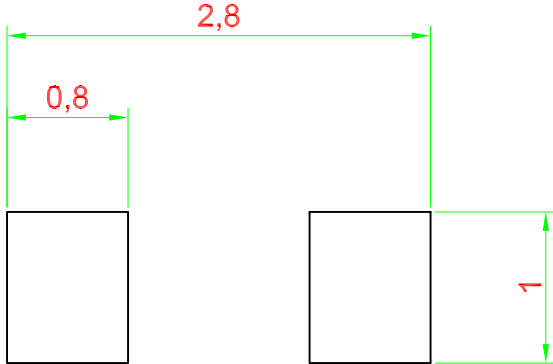

Improved Design For Better Heat Dissipation

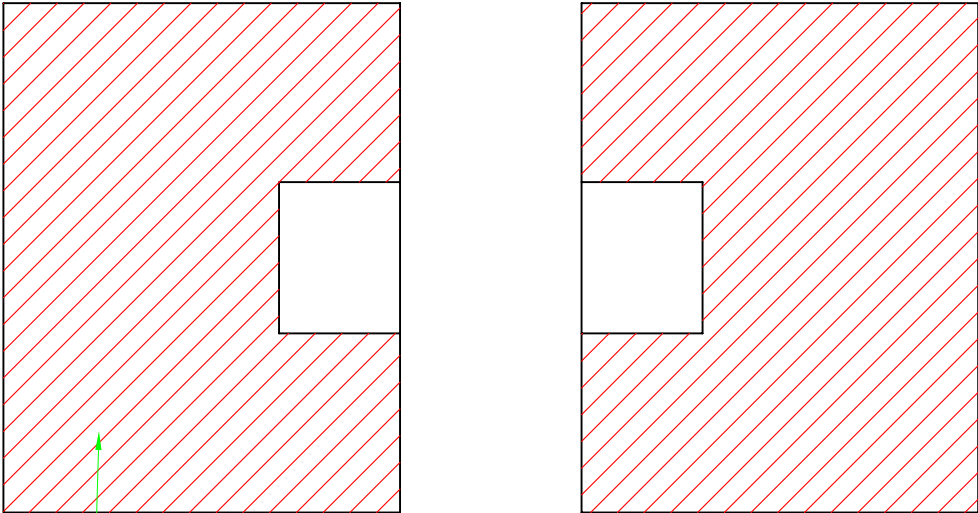

Additional Cu area for improved heat dissipation, > 16mm sq.

 Solder resist.



### Taping and orientation

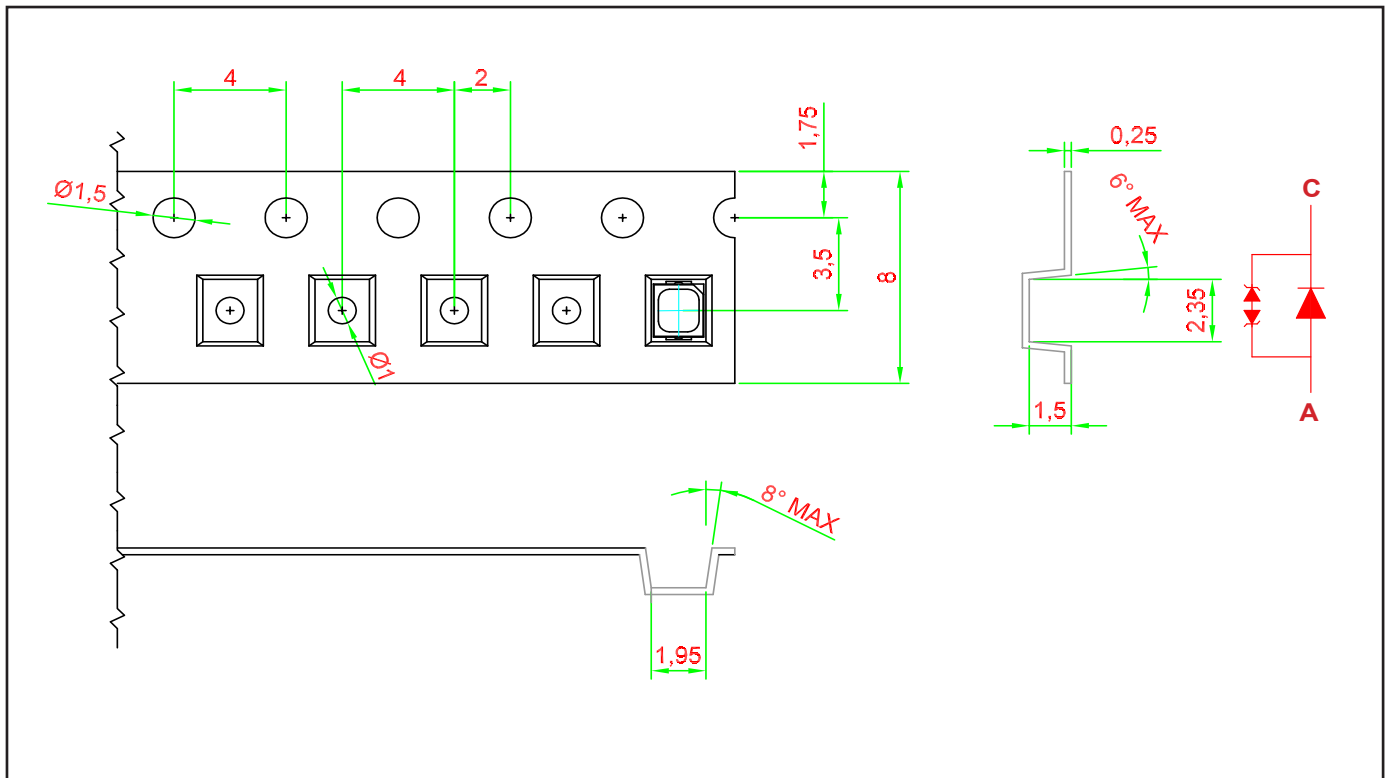

**Packaging Specification**

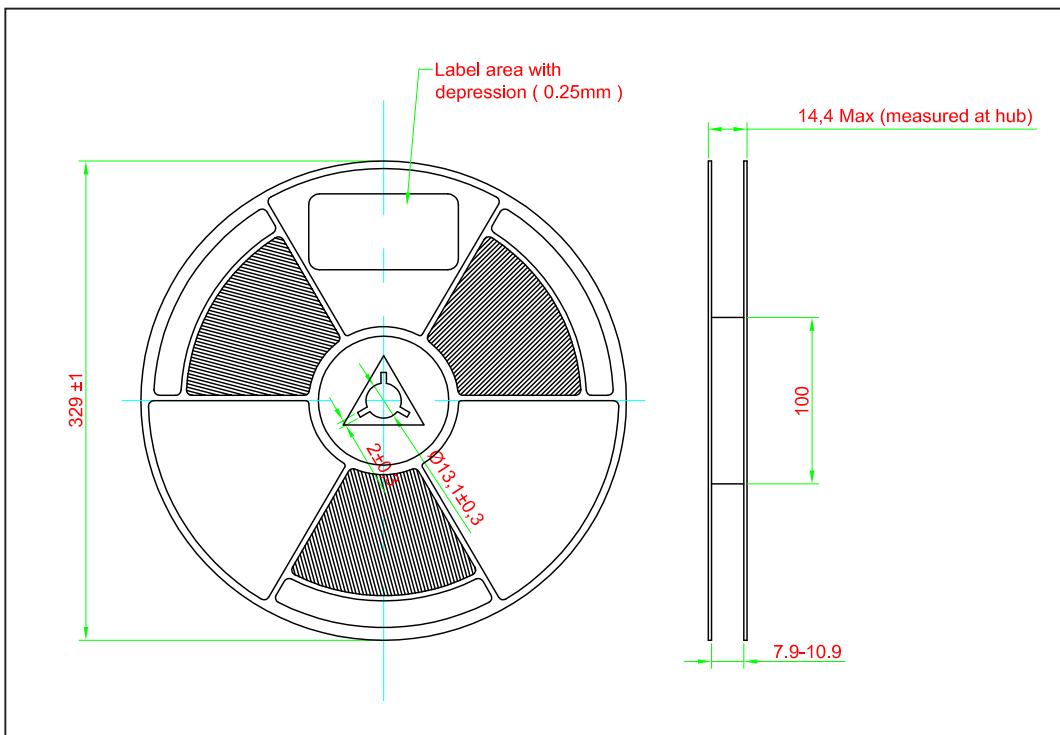
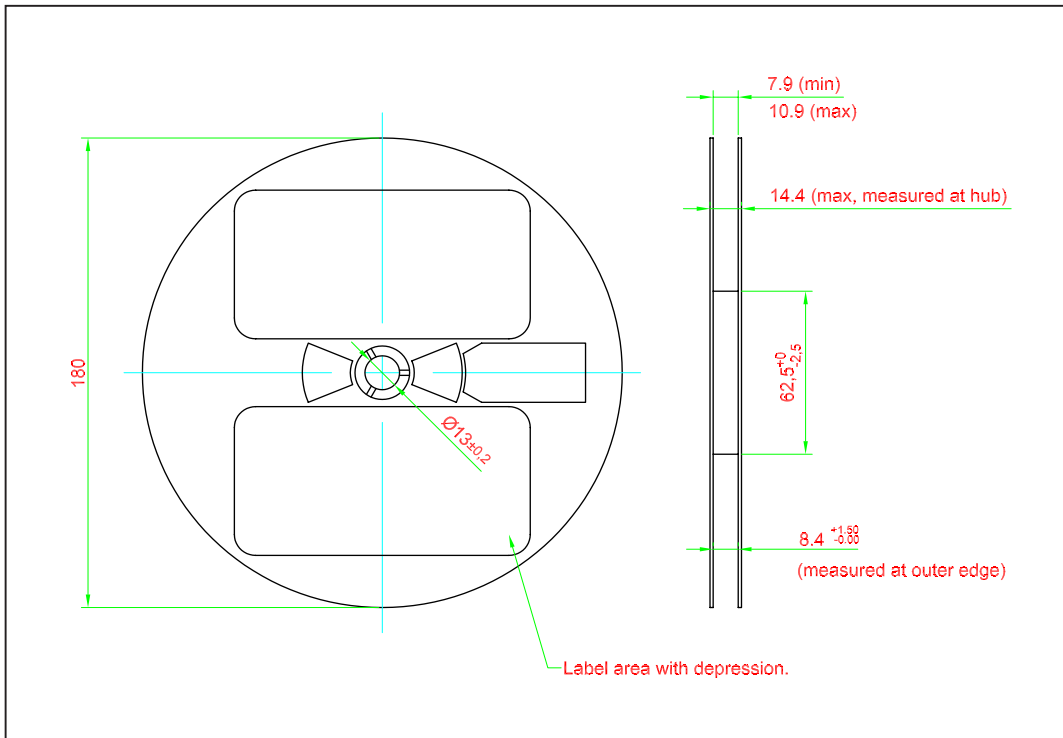

	Reel Diameter (mm)	Quantity (pcs)	*Ordering Number
Standard Packing	180	3000	DFZY-HZKG-xxx-x
Optional Packing	329	12000	DFZY-HZKG-xxx-x-K

Notes:

\* For ordering purpose only. Please consult sales and marketing for details.

**Packaging Specification**

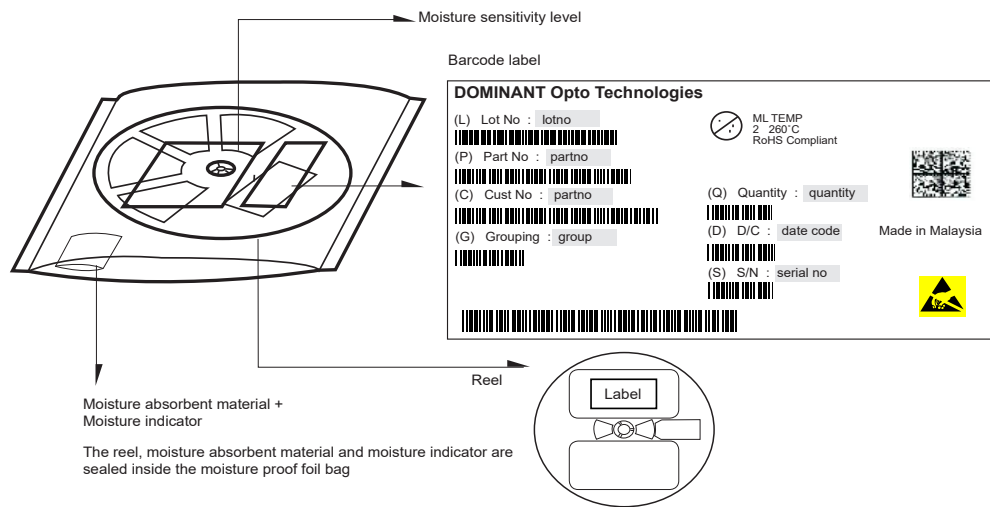

Quantity per bag (pcs)	Average 1pc MiniPlus DomiLED	1 completed bag (gram)
3000	0.008	203 ± 10
12000	0.008	555 ± 10

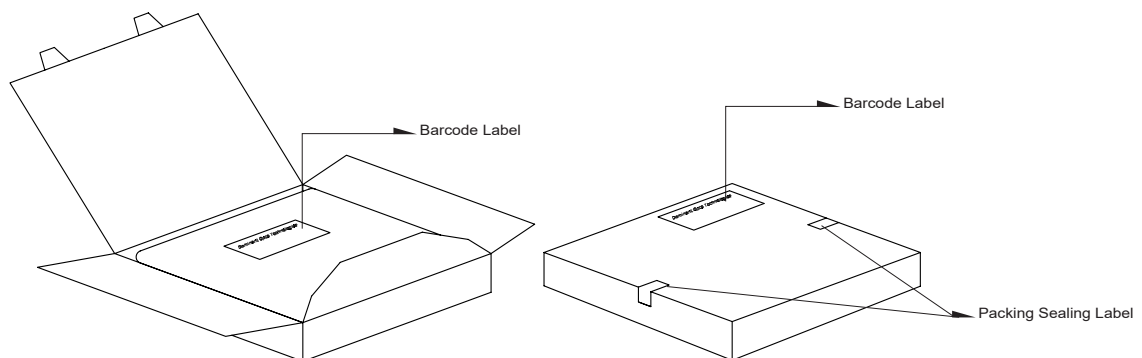

Reel Diameter (mm)	Packing Box Dimensions (mm)
180	210 x 210 x 16
329	345 x 345 x 16

## Recommended Pb-free Soldering Profile

Product complies to MSL Level 2 acc. to JEDEC J-STD-020E

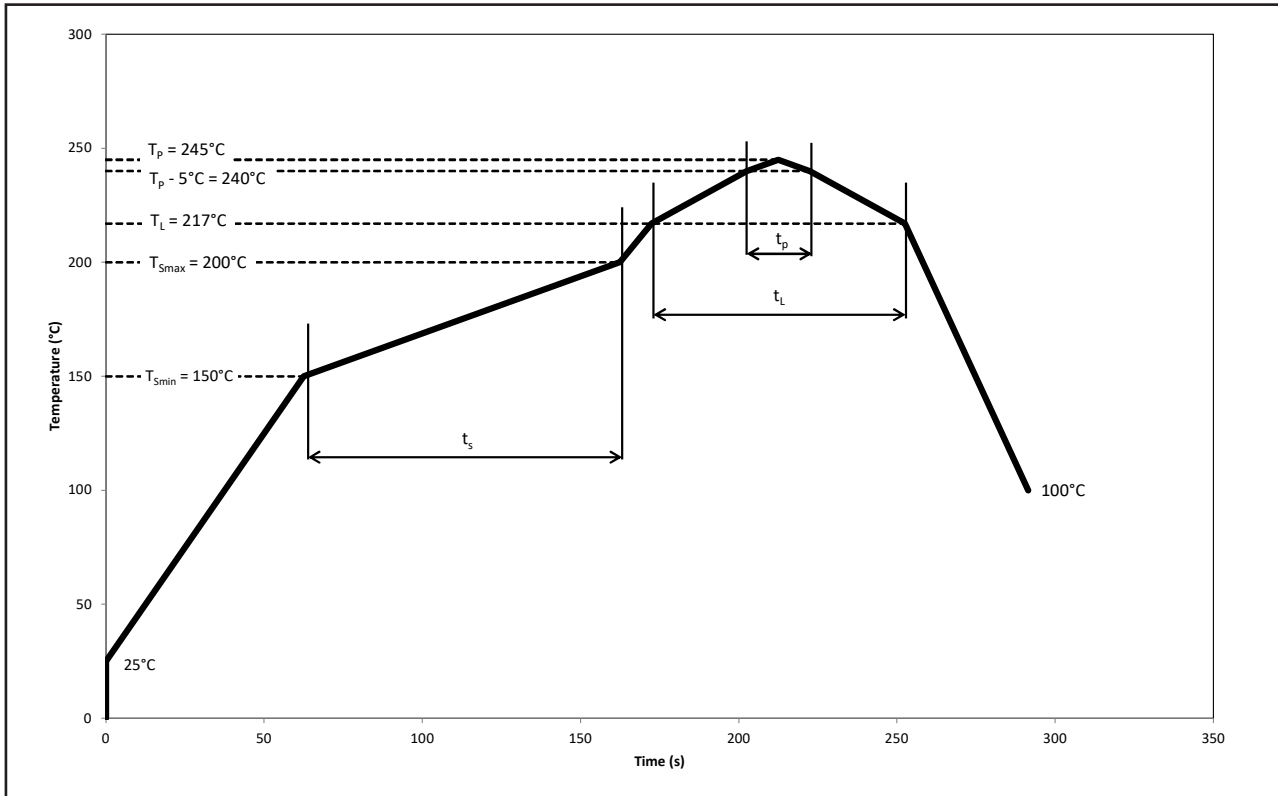

Profile Feature	Symbol	Pb-Free Assembly			Unit
		Min.	Recommended	Max.	
Ramp-up rate to preheat 25°C to $T_{smin}$	-	-	2	3	°C/s
Time $t_s$ $T_{smin}$ to $T_{smax}$	$t_s$	60	100	120	s
Ramp-up rate to peak $T_L$ to $T_p$	-	-	2	3	°C/s
Liquidous temperature	$T_L$	-	217	-	°C
Time above liquidous temperature	$t_L$	60	80	150	s
Peak temperature	$T_p$	-	245	260	°C
Time within 5°C of the specified peak temperature $T_p - 5^\circ\text{C}$	$t_p$	10	20	30	s
Ramp-down rate $T_p$ to 100°C	-	-	3	6	°C/s
Time 25°C to $T_p$	-	-	-	480	s

## Appendix

### 1) **Brightness:**

- 1.1 Luminous intensity is measured at current pulse 25 ms(typ) with an internal reproducibility of  $\pm 8\%$  and an expanded uncertainty of  $\pm 11\%$  (according to GUM with a coverage factor of  $k=3$ ).
- 1.2 Luminous flux is measured at current pulse 25 ms(typ) with an internal reproducibility of  $\pm 8\%$  and an expanded uncertainty of  $\pm 11\%$  (according to GUM with a coverage factor of  $k=3$ ).
- 1.3 Radiant intensity is measured at current pulse 25 ms(typ) with an internal reproducibility of  $\pm 8\%$  and an expanded uncertainty of  $\pm 11\%$  (according to GUM with a coverage factor of  $k=3$ ).
- 1.4 Radiant flux is measured at current pulse 25 ms(typ) with an internal reproducibility of  $\pm 8\%$  and an expanded uncertainty of  $\pm 11\%$  (according to GUM with a coverage factor of  $k=3$ ).

### 2) **Color:**

- 2.1 Chromaticity coordinate groups are measured at current pulse 25 ms(typ) with an internal reproducibility of  $\pm 0.005$  and an expanded uncertainty of  $\pm 0.01$  (accordingly to GUM with a coverage factor of  $k=3$ ).
- 2.2 Dominant wavelength is measured at current pulse 25 ms(typ) with an internal reproducibility of  $\pm 0.5\text{nm}$  and an expanded uncertainty of  $\pm 1\text{nm}$  (accordingly to GUM with a coverage factor of  $k=3$ ).

### 3) **Voltage:**

- 3.1 Forward Voltage,  $V_f$  is measured when a current pulse of 8 ms(typ) with an internal reproducibility of  $\pm 0.05\text{V}$  and an expanded uncertainty of  $\pm 0.1\text{V}$  (accordingly to GUM with a coverage factor of  $k=3$ ).

### 4) **Typical Values:**

- 4.1 At special conditions of LED manufacturing processes, typical data or calculated correlations of technical parameters only reflect the statistical figures. But not necessarily correspond to the actual parameters of each single product, which could differ from the typical data or calculated correlations or the typical characteristic line. These typical data may change whenever technical improvements happen.

### 5) **Tolerance of Measure**

- 5.1 Unless otherwise noted in drawing, tolerances are specified with  $\pm 0.1$  and dimension are specific in mm.

### 6) **Reverse Voltage:**

- 6.1 Not designed for reverse operation. Continuous reverse voltage can cause migration and LED damage.



## About Us

DOMINANT Opto Technologies is a dynamic company that is amongst the world's leading automotive LED manufacturers. With an extensive industry experience and relentless pursuit of innovation, DOMINANT's state-of-art manufacturing and development capabilities have become a trusted and reliable brand across the globe. More information about DOMINANT Opto Technologies, an IATF 16949 and ISO 14001 certified company, can be found under <http://www.dominant-semi.com>.

### **Please contact us for more information:**

DOMINANT Opto Technologies Sdn. Bhd  
Lot 6, Batu Berendam, FTZ Phase III, 75350 Melaka, Malaysia.  
Tel: +606 283 3566 Fax: +606 283 0566  
E-mail: [sales@dominant-semi.com](mailto:sales@dominant-semi.com)