

Domiled

Synonymous with function and performance, the Domiled series is perfectly suited for a variety of cross-industrial applications due to its small package outline, durability and superior brightness.



Features:

- > High brightness surface mount LED.
- > 120° viewing angle.
- > Small package outline (LxWxH) of 3.2 x 2.8 x 1.8mm.
- > Qualified according to JEDEC moisture sensitivity Level 2.
- > Compatible to IR reflow soldering.
- > Environmental friendly; RoHS compliance.
- > Compliance to automotive standard, AEC-Q102.
- > Passed Corrosion Resistant Test. *Appx. 6.1*



Applications:

- > Automotive: interior applications, eg: switches, telematics, climate control system, dashboard, etc.
- > Consumer Appliances: LCD illumination as in PDAs, LCD TV.
- > Communication: indicator and backlight in mobilephone.
- > Signage: full color display video notice board.
- > Industrial: white goods (eg: Oven, microwave, etc.).

Optical Characteristics at Tj=25°C

Part Number	Color	Viewing Angle°	Luminous Intensity @ 20mA IV (mcd) <i>Appx. 1.1</i>		
			Min.	Typ.	Max.
DDT-HJS-VW1-1	True Green	120	715.0	1125.0	1400.0
DDT-HJS-V2W-1	True Green	120	900.0	1400.0	1800.0
DDB-HJS-TU1-1	Blue	120	285.0	425.0	560.0
● DDB-HJS-S2T-1	Blue	120	224.0	355.0	450.0

● Not for new design

Electrical Characteristics at Tj=25°C

Part Number	Vf @ If = 20mA <i>Appx. 3.1</i>			Vr @ Ir = 10uA <i>Appx. 7.1</i>
	Min. (V)	Typ. (V)	Max. (V)	Min. (V)
DDx-HJS	2.9	3.2	3.6	5

Absolute Maximum Ratings

	Maximum Value	Unit
DC forward current	20	mA
Peak Pulse Current; (Ts = 55°C, tp = 100µs, D = 0.03)	100	mA
Reverse voltage; Ir (max) = 10uA <i>Appx. 7.1</i>	5	V
ESD threshold (HBM)	2000	V
LED junction temperature	125	°C
Operating temperature	-40 ... +100	°C
Storage temperature	-40 ... +100	°C
Power dissipation (at room temperature)	80	mW
Thermal resistance		
- Junction / ambient, Rth JA	340	K/W
- Junction / solder point, Rth JS	180	K/W

Wavelength Grouping at Tj=25°C

Color	Group	Wavelength distribution(nm) <small>Appx. 2.2</small>
DDT; True Green	Full	520.0 - 535.0
	A	520.0 - 525.0
	B	525.0 - 530.0
	C	530.0 - 535.0
DDB; Blue	Full	464.0 - 476.0
	A	464.0 - 470.0
	B	470.0 - 476.0

Luminous Intensity Group at Tj=25°C

Brightness Group	Luminous Intensity <small>Appx. 1.1</small> IV (mcd)
S2	224.0 ... 285.0
T1	285.0 ... 355.0
T2	355.0 ... 450.0
U1	450.0 ... 560.0
V1	715.0 ... 900.0
V2	900.0 ... 1125.0
W1	1125.0 ... 1400.0
W2	1400.0 ... 1800.0

Vf Bining (Optional)

Vf @ If = 20mA	Forward Voltage (V) <small>Appx. 3.1</small>
V11	2.85 ... 3.00
V12	3.00 ... 3.15
V13	3.15 ... 3.30
V14	3.30 ... 3.45
V15	3.45 ... 3.60

Please consult sales and marketing to incorporate special part number to incorporate Vf binning.

Relative Luminous Intensity Vs Forward Current

$I_v/I_v(20\text{mA}) = f(I_F); T_j = 25^\circ\text{C}$

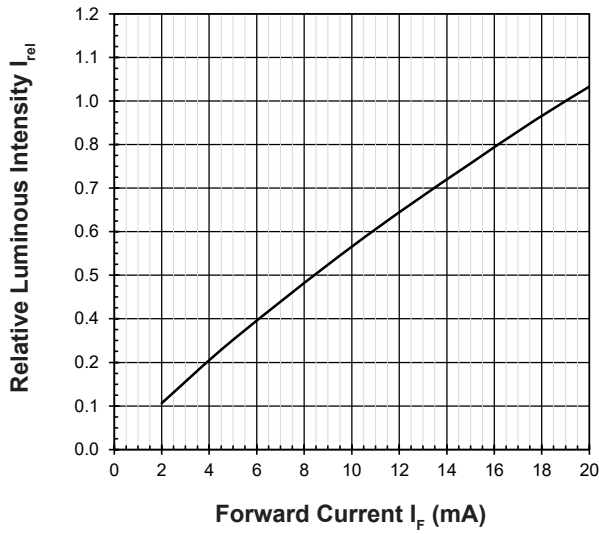

Forward Current Vs Forward Voltage

$I_F = f(V_F); T_j = 25^\circ\text{C}$

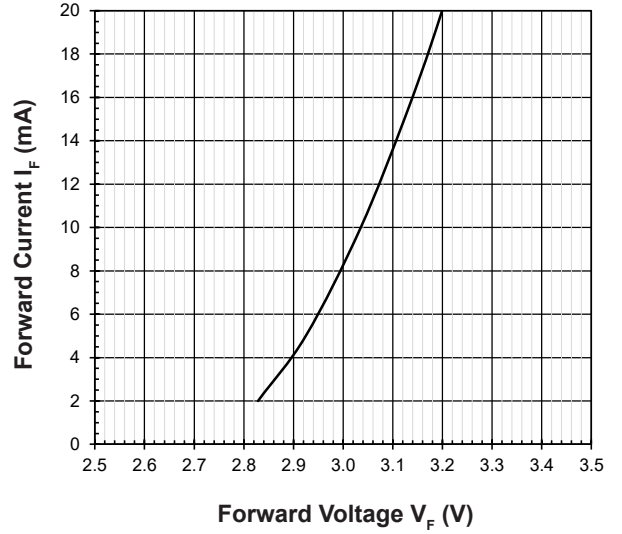

Maximum Current Vs Temperature

$I_F = f(T)$

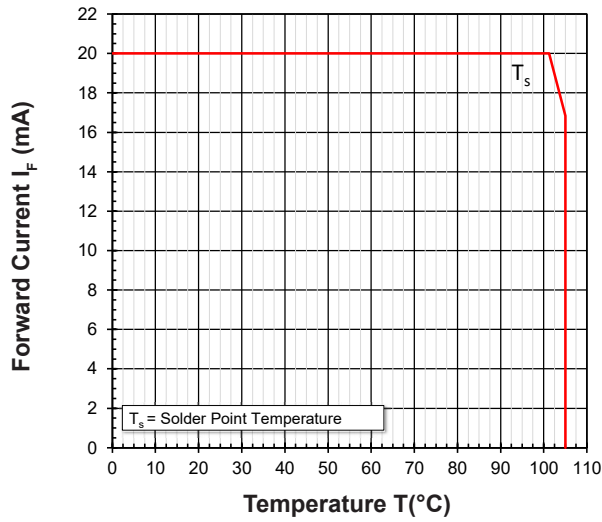

Relative Spectral Emission

$I_{rel} = f(\lambda); T_j = 25^\circ\text{C}; I_F = 20\text{mA}$

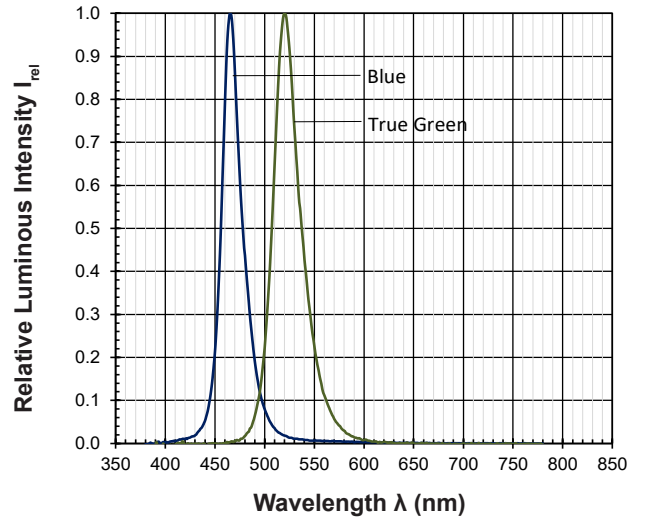

Allowable Forward Current Vs Duty Ratio

$(T_s = 55^\circ\text{C}; t_p \leq 100\mu\text{s})$

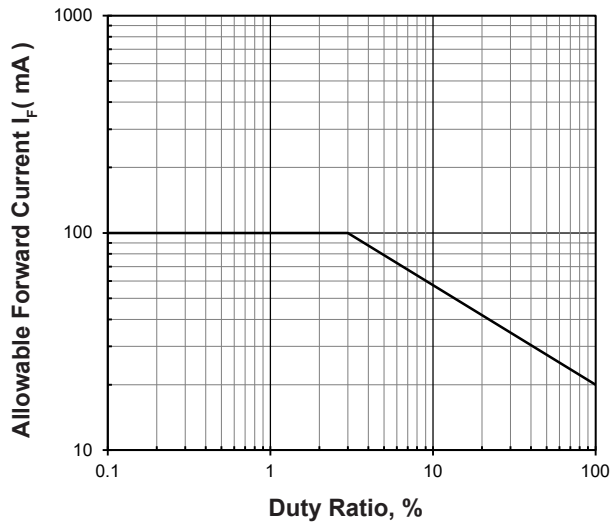

Radiation Pattern

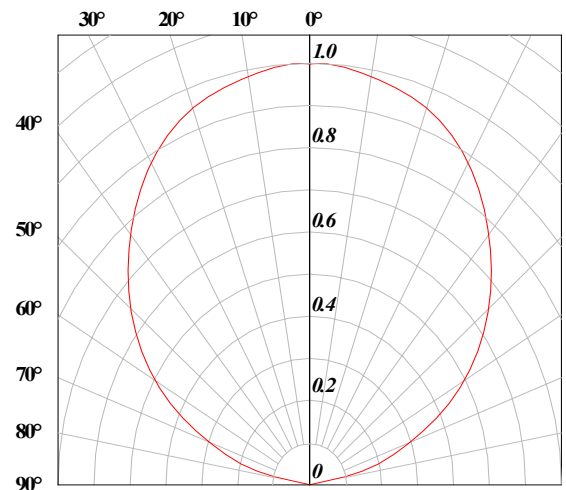

Wavelength Shift Vs Forward Current

$\lambda_{dom} = f(I_F); T_j = 25^\circ\text{C}$

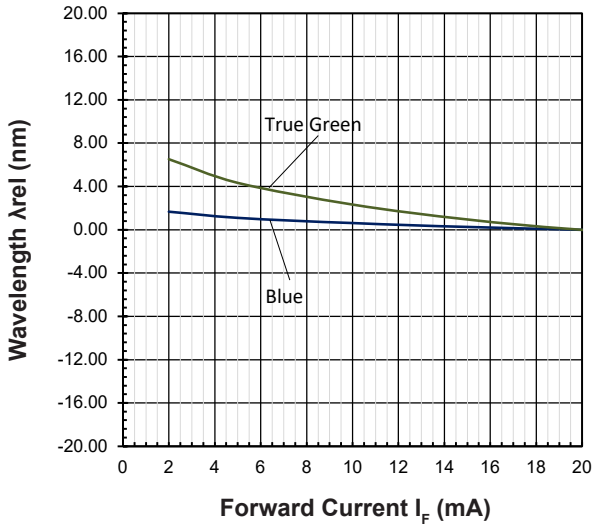

Forward Voltage Vs Junction Temperature

$\Delta V_F = V_F - V_F(25^\circ\text{C}) = f(T_j); I_F = 20\text{mA}$

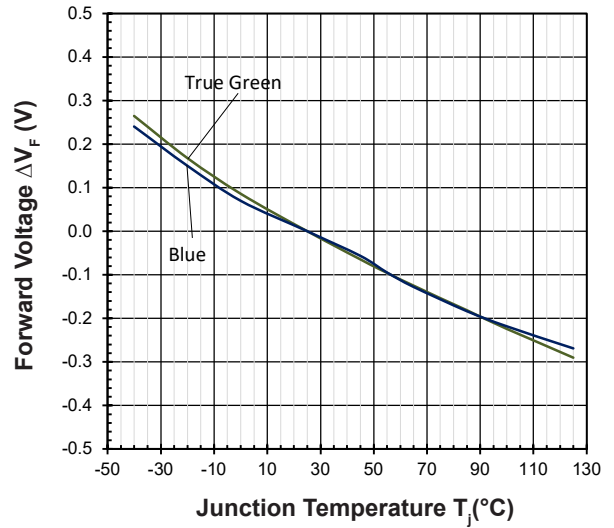

Relative Luminous Intensity Vs Junction Temperature

$I_V/I_V(25^\circ\text{C}) = f(T_j); I_F = 20\text{mA}$

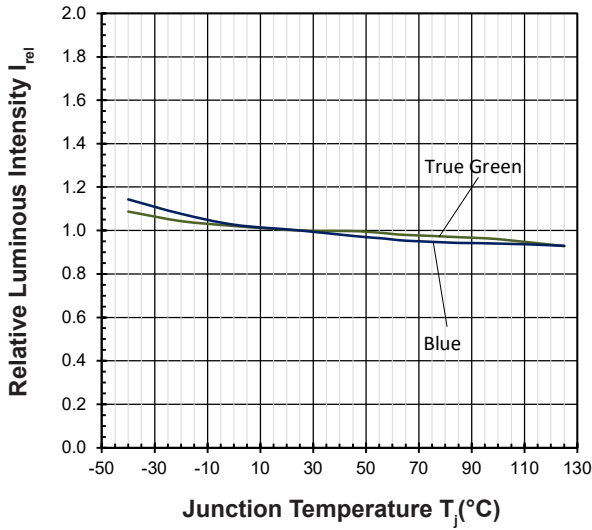

Wavelength Vs Junction Temperature

$\Delta \lambda_{dom} = \lambda_{dom} - \lambda_{dom}(25^\circ\text{C}) = f(T_j); I_F = 20\text{mA}$

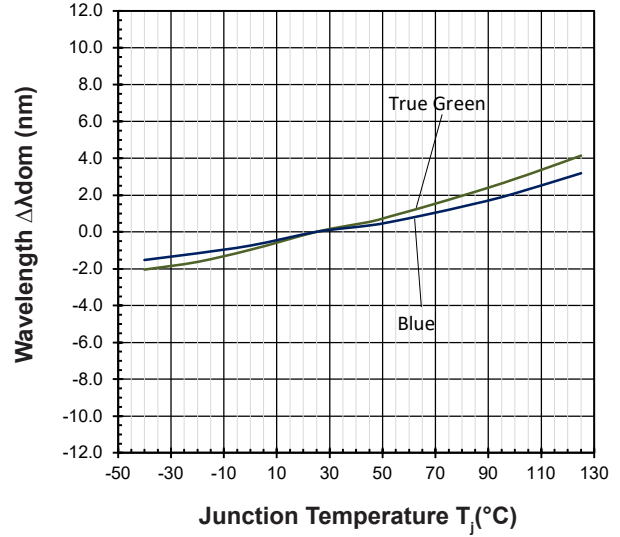

Domiled • InGaN : DDx-HJS Package Outlines

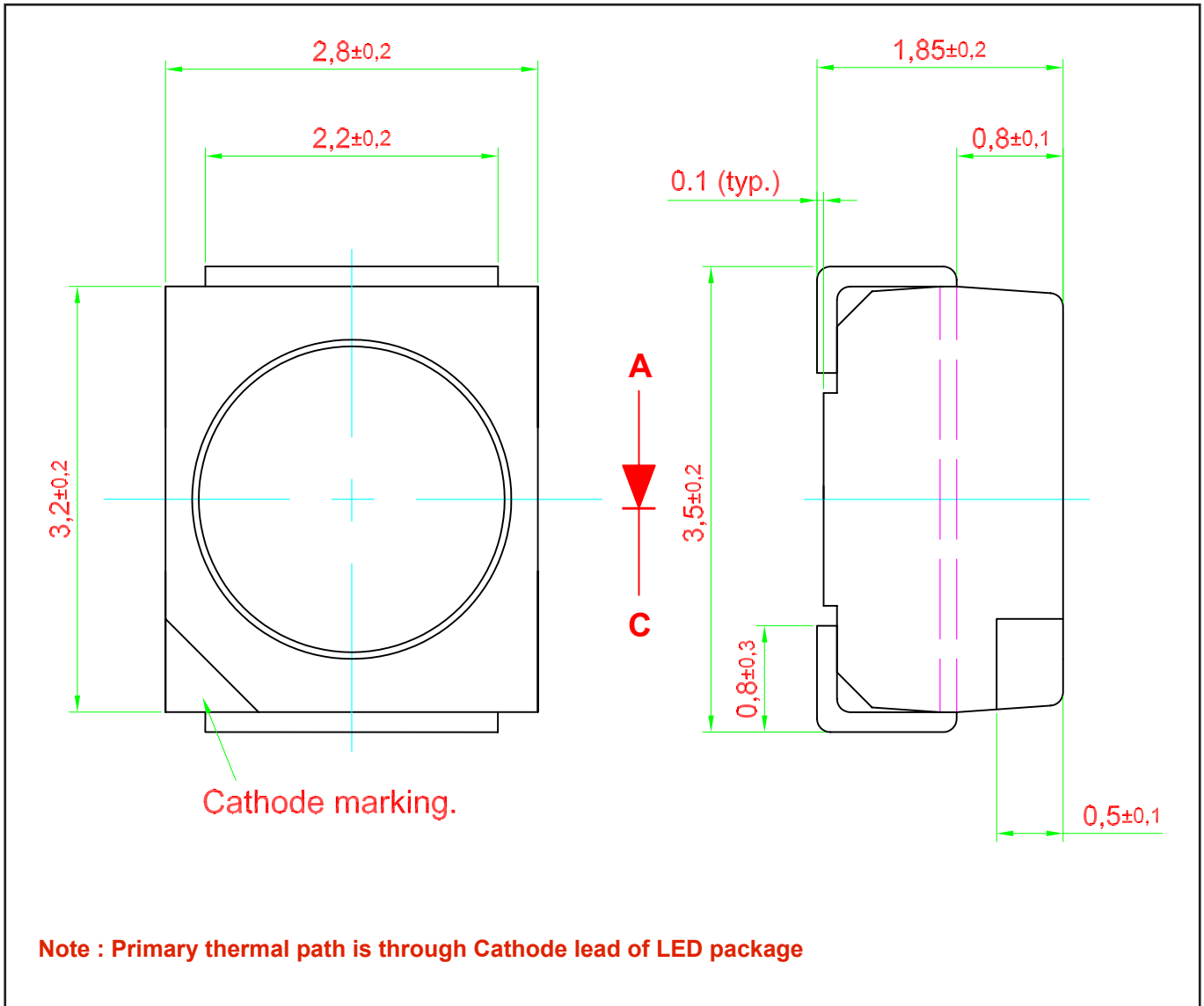

Material

Material	
Lead-frame	Cu Alloy With Ag Plating
Package	High Temperature Resistant Plastic
Encapsulant	Epoxy Resin
Soldering Leads	Sn Plating

Recommended Solder Pad

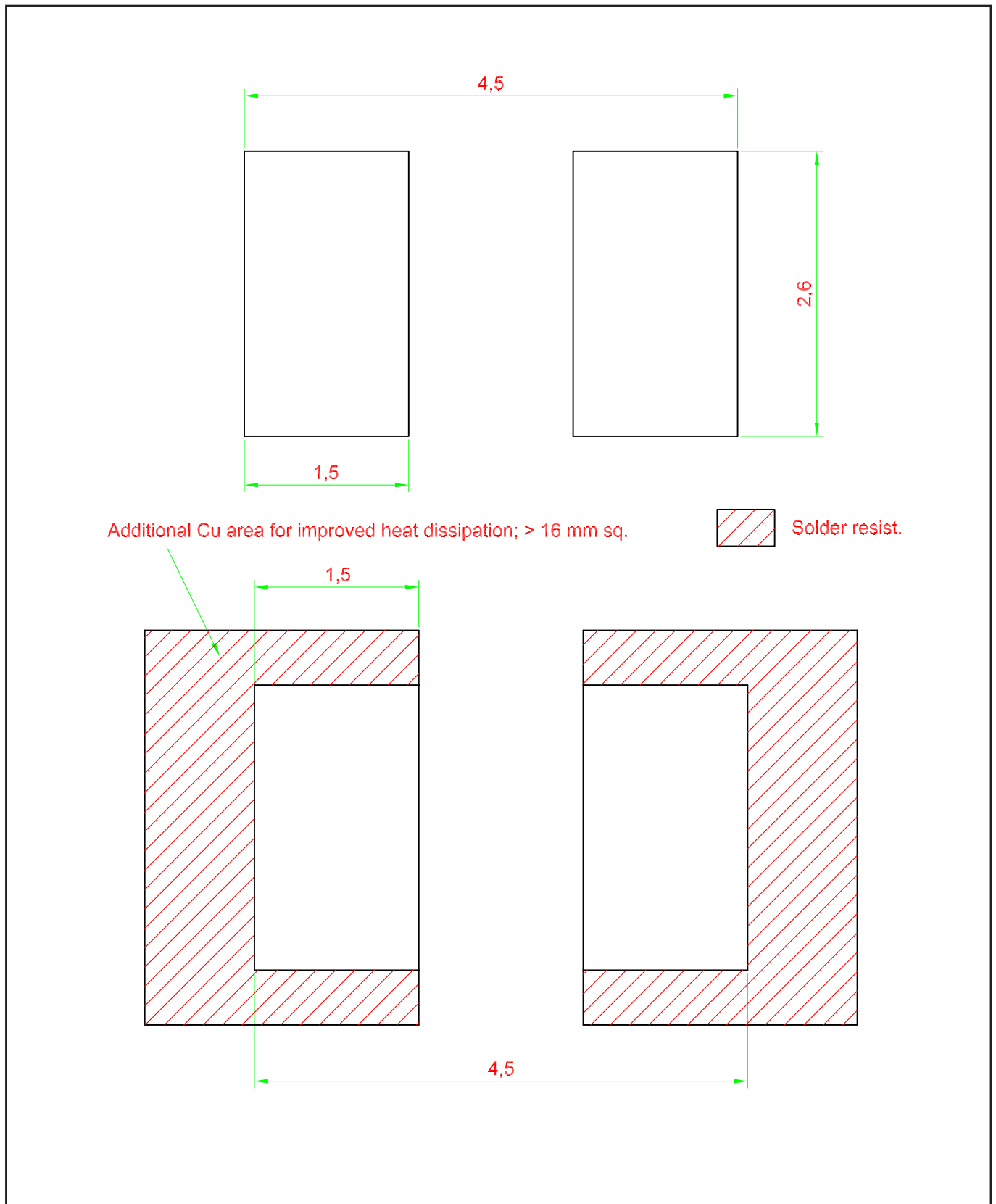

Taping and orientation

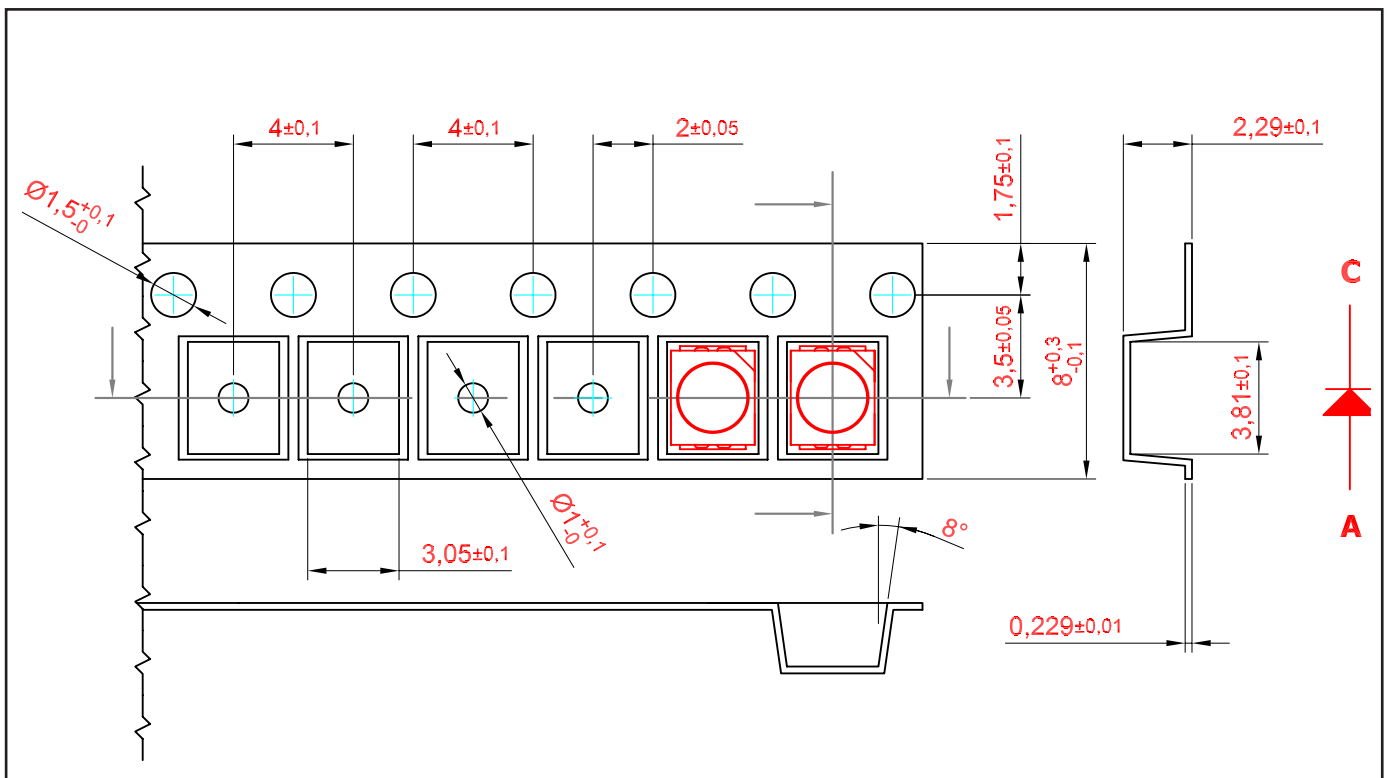

200 mm min. for $\varnothing 180$ reel.
 200 mm min. for $\varnothing 330$ reel.

480 mm min. for $\varnothing 180$ reel.
 960 mm min. for $\varnothing 330$ reel.

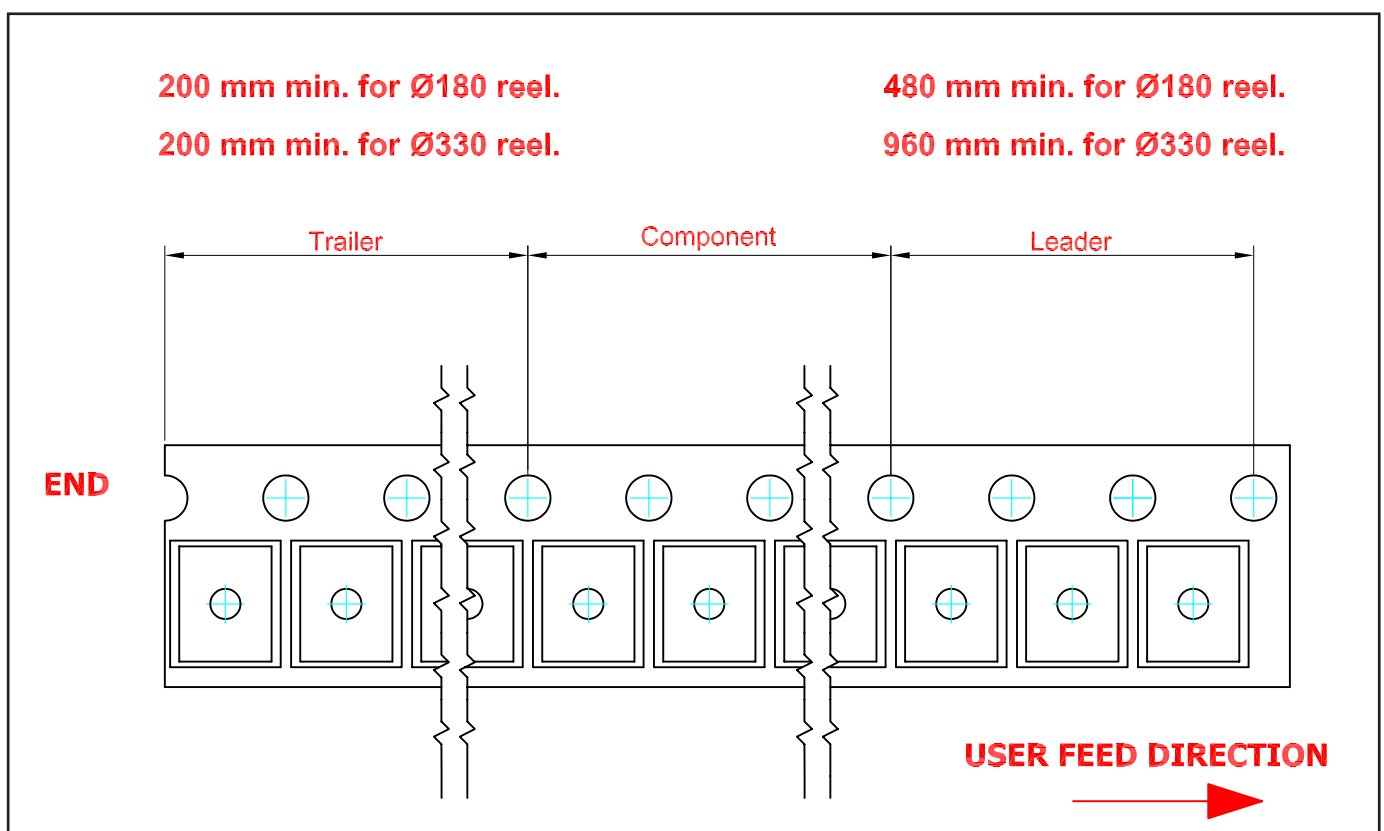

Packaging Specification

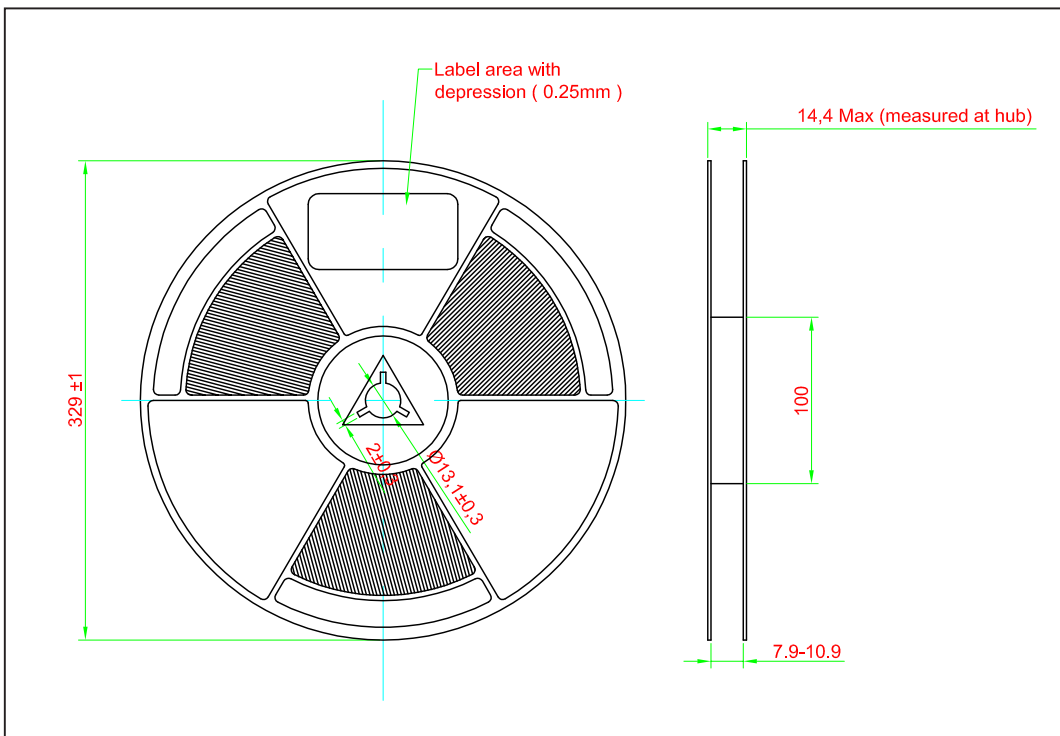
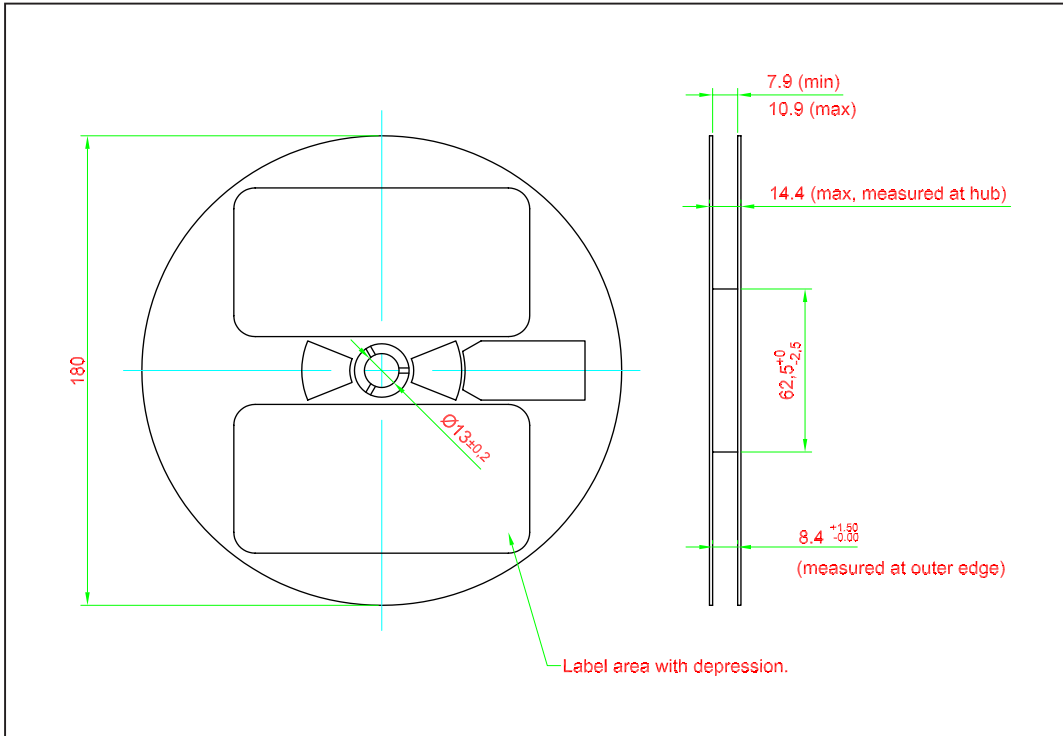

	Reel Diameter (mm)	Quantity (pcs)	*Ordering Number
Standard Packing	180	2000	DDx-HJS-xxx-1
Optional Packing	329	8000	DDx-HJS-xxx-1-8

Notes:

* For ordering purpose only. Please consult sales and marketing for details.

Packaging Specification

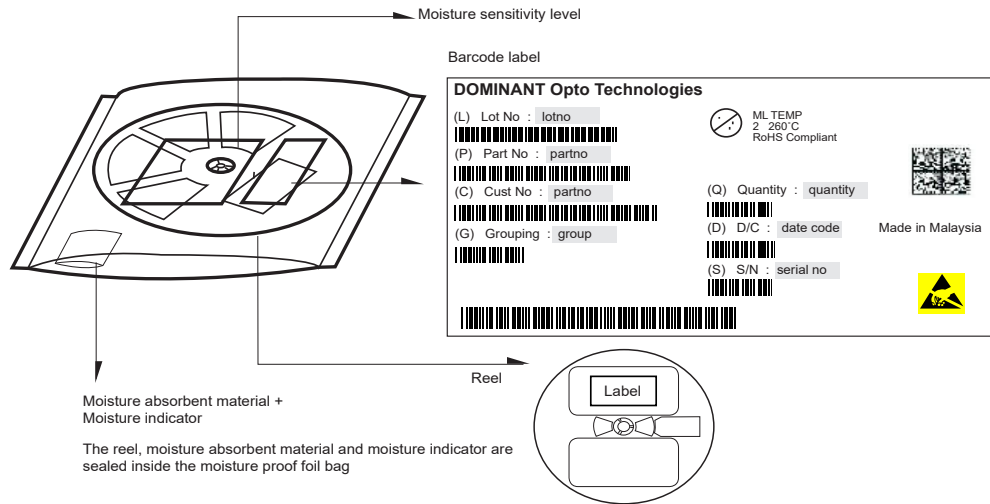

Quantity per bag (pcs)	Average 1pc DomiLED (g)	1 completed bag (g)
2000	0.034	240 ± 10
8000	0.034	750 ± 10

Recommended Pb-free Soldering Profile

Product complies to MSL Level 2 acc. to JEDEC J-STD-020E

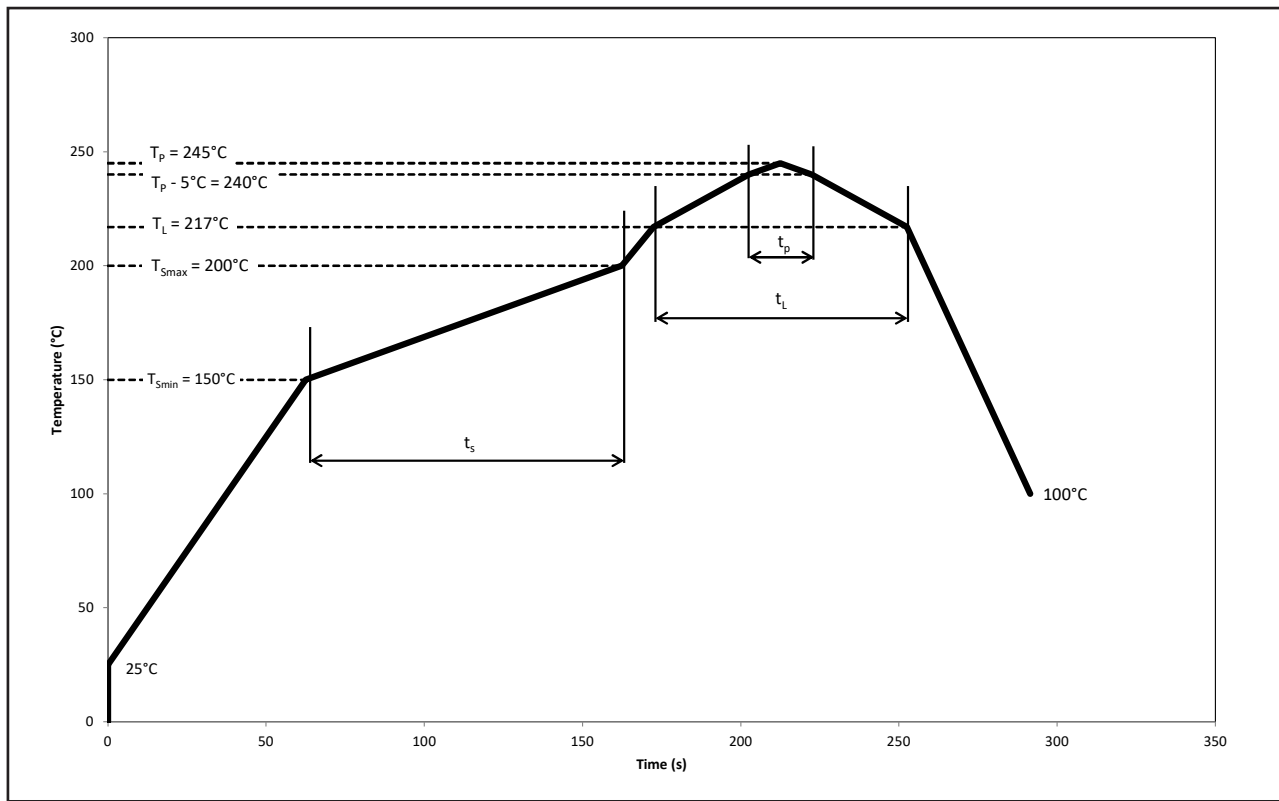

Profile Feature	Symbol	Pb-Free Assembly			Unit
		Min.	Recommended	Max.	
Ramp-up rate to preheat 25°C to T_{smin}	-	-	2	3	°C/s
Time t_s T_{smin} to T_{smax}	t_s	60	100	120	s
Ramp-up rate to peak T_L to T_p	-	-	2	3	°C/s
Liquidous temperature	T_L	-	217	-	°C
Time above liquidous temperature	t_L	60	80	150	s
Peak temperature	T_p	-	245	260	°C
Time within 5°C of the specified peak temperature $T_p - 5^\circ\text{C}$	t_p	10	20	30	s
Ramp-down rate T_p to 100°C	-	-	3	6	°C/s
Time 25°C to T_p	-	-	-	480	s

Appendix

1) **Brightness:**

- 1.1 Luminous intensity is measured at current pulse 25 ms(typ) with an internal reproducibility of $\pm 8\%$ and an expanded uncertainty of $\pm 11\%$ (according to GUM with a coverage factor of $k=3$).
- 1.2 Luminous flux is measured at current pulse 25 ms(typ) with an internal reproducibility of $\pm 8\%$ and an expanded uncertainty of $\pm 11\%$ (according to GUM with a coverage factor of $k=3$).
- 1.3 Radiant intensity is measured at current pulse 25 ms(typ) with an internal reproducibility of $\pm 8\%$ and an expanded uncertainty of $\pm 11\%$ (according to GUM with a coverage factor of $k=3$).
- 1.4 Radiant flux is measured at current pulse 25 ms(typ) with an internal reproducibility of $\pm 8\%$ and an expanded uncertainty of $\pm 11\%$ (according to GUM with a coverage factor of $k=3$).

2) **Color:**

- 2.1 Chromaticity coordinate groups are measured at current pulse 25 ms(typ) with an internal reproducibility of ± 0.005 and an expanded uncertainty of ± 0.01 (accordingly to GUM with a coverage factor of $k=3$).
- 2.2 Dominant wavelength is measured at current pulse 25 ms(typ) with an internal reproducibility of $\pm 0.5\text{nm}$ and an expanded uncertainty of $\pm 1\text{nm}$ (accordingly to GUM with a coverage factor of $k=3$).

3) **Voltage:**

- 3.1 Forward Voltage, V_f is measured when a current pulse of 8 ms(typ) with an internal reproducibility of $\pm 0.05\text{V}$ and an expanded uncertainty of $\pm 0.1\text{V}$ (accordingly to GUM with a coverage factor of $k=3$).

4) **Typical Values:**

- 4.1 At special conditions of LED manufacturing processes, typical data or calculated correlations of technical parameters only reflect the statistical figures. But not necessarily correspond to the actual parameters of each single product, which could differ from the typical data or calculated correlations or the typical characteristic line. These typical data may change whenever technical improvements happen.

5) **Tolerance of Measure**

- 5.1 Unless otherwise noted in drawing, tolerances are specified with ± 0.1 and dimension are specific in mm.

6) **Corrosion Robustness:**

- 6.1 Test conditions: 40 °C / 90 % rh / 15 ppm H_2S / 336 h.
= Stricter than IEC 60068-2-43 (H_2S) [25 °C / 75% rh / 10 ppm H_2S / 21 days].

7) **Reverse Voltage:**

- 7.1 Not designed for reverse operation. Continuous reverse voltage can cause migration and LED damage.

Revision History

Page	Subjects	Date of Modification
-	Initial Release	06 Apr 2009
2	Add Thermal Resistance	14 Apr 2010
2	Add partno: DDT-HJS-VW1-1	16 Dec 2010
2	Add partno: DDB-HJS-TU1-1 Not for new design: DDB-HJS-S2T-1	12 Sep 2011
4	Update Graph: Relative Luminous Intensity Vs Forward Current	29 Dec 2011
5	Add graph: Allowable Forward Current Vs Duty Ratio	18 Jun 2012
1, 3, 6, 10	Add Features Add Characteristics Add Remarks in Package Outline Update Package Specification	26 Nov 2015
1, 12	Update Product Photo and Features Add Appendix	19 Sep 2016
1, 12	Update Features Update Appendix	29 Sep 2016
4	Add Vf Binning (Optional)	09 Jun 2017
10, 11, 12, 14	Update Package Specification Update Appendix	03 Aug 2020
1, 2, 5, 6, 11, 12	Update Features: AEC-Q101 to AEC-Q102 Update Test Condition for Peak Pulse Current Update Graph Update Packaging Specification Update Recommended Pb-free Soldering Profile	29 Mar 2024

NOTE

All the information contained in this document is considered to be reliable at the time of publishing. However, DOMINANT Opto Technologies does not assume any liability arising out of the application or use of any product described herein.

DOMINANT Opto Technologies reserves the right to make changes to any products in order to improve reliability, function or design.

DOMINANT Opto Technologies products are not authorized for use as critical components in life support devices or systems without the express written approval from the Managing Director of DOMINANT Opto Technologies.

Dispose of product is in accordance with local, regional, national and international regulations..

About Us

DOMINANT Opto Technologies is a dynamic company that is amongst the world's leading automotive LED manufacturers. With an extensive industry experience and relentless pursuit of innovation, DOMINANT's state-of-art manufacturing and development capabilities have become a trusted and reliable brand across the globe. More information about DOMINANT Opto Technologies, an IATF 16949 and ISO 14001 certified company, can be found under <http://www.dominant-semi.com>.

Please contact us for more information:

DOMINANT Opto Technologies Sdn. Bhd.
Lot 6, Batu Berendam, FTZ Phase III, 75350 Melaka, Malaysia
Tel: (606) 283 3566 Fax: (606) 283 0566
E-mail: sales@dominant-semi.com