

Domiled

With the intense colors that seem to glow with energy and its significant brightness, Domiled white LED is a highly reliable design device. Its dynamic nature makes it perfect choice for lighthing applications, office and home applications and standard industrial applications.



Features:

- > High brightness surface mount LED.
- > 120° viewing angle.
- > Small package outline.
- > Qualified according to JEDEC moisture sensitivity Level 2.
- > Compatible to both IR reflow soldering.
- > Environmental friendly; RoHS compliance.
- > Compliance to automotive standard; AEC-Q101.
- > Minimum CRI of 90.

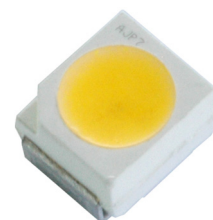

Applications:

- > Automotive: Interior applications, eg: switches, telematics, climate control system, dashboard, etc



Optical Characteristics at Tj=25°C

Part Number	Color	Viewing Angle°	Luminous Intensity @ IF = 20mA		IV (mcd) <i>Appx. 1.1</i>
			Min.	Typ.	
DDF-NJJ-W2X-4L9Q	Warm White	120	1400.0	2240.0	2850.0

NOTE

1. High color rendering index (CRI). Minimum CRI of 90 & minimum R9 of 65.

Electrical Characteristics at Tj=25°C

Part Number	Vf @ If = 20 mA <i>Appx. 3.1</i>			Vr @ Ir = 10 µA <i>Appx. 6.1</i>
	Min. (V)	Typ. (V)	Max. (V)	Min. (V)
DDF-NJJ	2.8	3.2	3.5	5.0

Absolute Maximum Ratings

	Maximum Value	Unit
DC forward current	50	mA
Peak pulse current; (tp ≤ 10µs, Duty cycle = 0.005)	100	mA
Reverse voltage; Ir max = 10µA <i>Appx. 6.1</i>	5	V
ESD threshold (HBM)	2000	V
LED junction temperature	125	°C
Operating temperature	-40 ... +110	°C
Storage temperature	-40 ... +110	°C
Power dissipation (at room temperature)	180	mW
Thermal resistance (Rated current = 20mA, Ts = 25 °C)		
- Real Thermal Resistance	315	K/W
Junction / ambient, Rth JA real	145	K/W
Junction / solder point, Rth JS real		

DDF-NJJ, Color Grouping *Appx. 2.1*

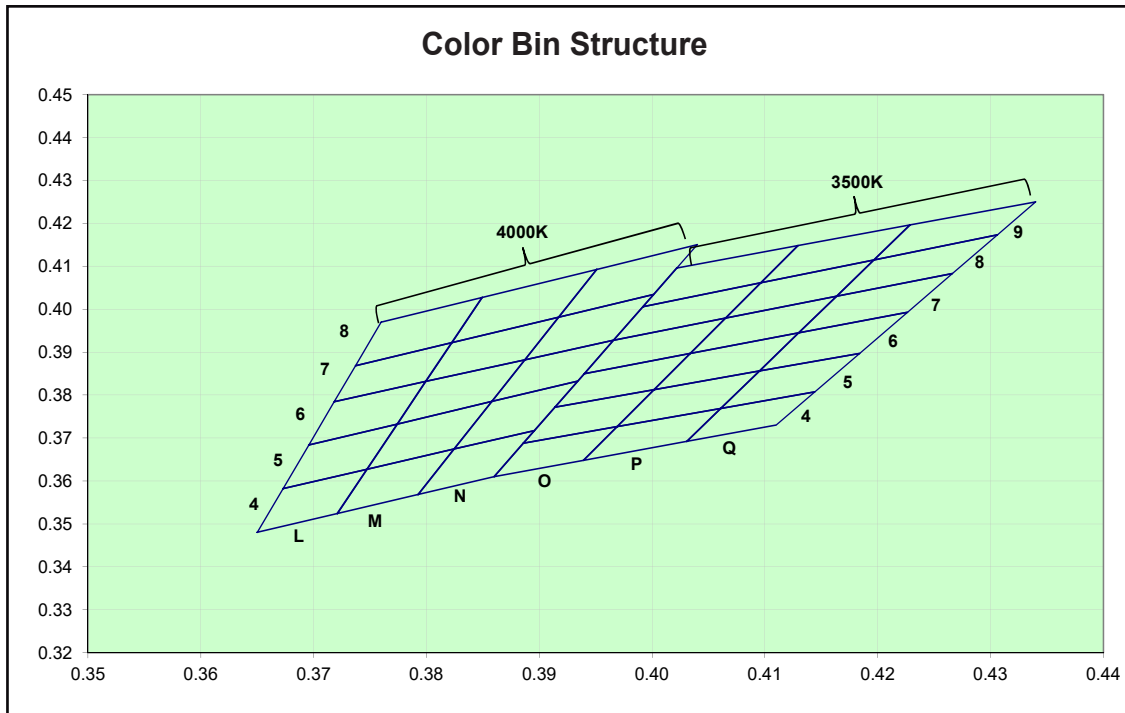

Bin		1	2	3	4
4L	Cx	0.3650	0.3670	0.3750	0.3720
	Cy	0.3480	0.3580	0.3620	0.3520
5L	Cx	0.3670	0.3690	0.3770	0.3750
	Cy	0.3580	0.3680	0.3730	0.3620
6L	Cx	0.3690	0.3710	0.3800	0.3770
	Cy	0.3680	0.3780	0.3830	0.3730
7L	Cx	0.3710	0.3740	0.3830	0.3800
	Cy	0.3780	0.3870	0.3930	0.3830
8L	Cx	0.3740	0.3760	0.3850	0.3830
	Cy	0.3870	0.3970	0.4030	0.3930
4M	Cx	0.3720	0.3750	0.3820	0.3790
	Cy	0.3520	0.3620	0.3670	0.3560
5M	Cx	0.3750	0.3770	0.3850	0.3820
	Cy	0.3620	0.3730	0.3780	0.3670
6M	Cx	0.3770	0.3800	0.3880	0.3850
	Cy	0.3730	0.3830	0.3880	0.3780
7M	Cx	0.3800	0.3830	0.3920	0.3880
	Cy	0.3830	0.3930	0.3990	0.3880
8M	Cx	0.3830	0.3850	0.3950	0.3920
	Cy	0.3930	0.4030	0.4090	0.3990

Bin		1	2	3	4
4N	Cx	0.3790	0.3820	0.3900	0.3860
	Cy	0.3560	0.3670	0.3720	0.3610
5N	Cx	0.3820	0.3850	0.3930	0.3900
	Cy	0.3670	0.3780	0.3830	0.3720
6N	Cx	0.3850	0.3880	0.3970	0.3930
	Cy	0.3780	0.3880	0.3930	0.3830
7N	Cx	0.3880	0.3920	0.4010	0.3970
	Cy	0.3880	0.3990	0.4040	0.3930
8N	Cx	0.3920	0.3950	0.4040	0.4010
	Cy	0.3990	0.4090	0.4150	0.4040
4O	Cx	0.3860	0.3890	0.3980	0.3940
	Cy	0.3610	0.3690	0.3730	0.3650
5O	Cx	0.3890	0.3910	0.4010	0.3980
	Cy	0.3690	0.3770	0.3810	0.3730
6O	Cx	0.3910	0.3940	0.4040	0.4010
	Cy	0.3770	0.3850	0.3900	0.3810
7O	Cx	0.3940	0.3970	0.4070	0.4040
	Cy	0.3850	0.3930	0.3980	0.3900
8O	Cx	0.3970	0.4000	0.4100	0.4070
	Cy	0.3930	0.4010	0.4060	0.3980
9O	Cx	0.4000	0.4030	0.4130	0.4100
	Cy	0.4010	0.4100	0.4150	0.4060
4P	Cx	0.3940	0.3980	0.4060	0.4030
	Cy	0.3650	0.3730	0.3770	0.3690
5P	Cx	0.3980	0.4010	0.4100	0.4060
	Cy	0.3730	0.3810	0.3860	0.3770
6P	Cx	0.4010	0.4040	0.4130	0.4100
	Cy	0.3810	0.3900	0.3940	0.3860
7P	Cx	0.4040	0.4070	0.4160	0.4130
	Cy	0.3900	0.3980	0.4030	0.3940
8P	Cx	0.4070	0.4100	0.4200	0.4160
	Cy	0.3980	0.4060	0.4120	0.4030
9P	Cx	0.4100	0.4130	0.4230	0.4200
	Cy	0.4060	0.4150	0.4200	0.4120
4Q	Cx	0.4030	0.4060	0.4150	0.4110
	Cy	0.3690	0.3770	0.3810	0.3730
5Q	Cx	0.4060	0.4100	0.4190	0.4150
	Cy	0.3770	0.3860	0.3900	0.3810
6Q	Cx	0.4100	0.4130	0.4220	0.4190
	Cy	0.3860	0.3940	0.3990	0.3900
7Q	Cx	0.4130	0.4160	0.4260	0.4220
	Cy	0.3940	0.4030	0.4080	0.3990
8Q	Cx	0.4160	0.4200	0.4300	0.4260
	Cy	0.4030	0.4120	0.4170	0.4080
9Q	Cx	0.4200	0.4230	0.4340	0.4300
	Cy	0.4120	0.4200	0.4250	0.4170

InGaN wavelength is very sensitive to drive current. Operating at lower current is not recommended and may yield unpredictable performance current pulsing should be used for dimming purposed.

Luminous Intensity Group at Tj=25°C

Brightness Group	Luminous Intensity <small>Appx. 1.1</small> IV (mcd)
W2	1400.0 ... 1800.0
X1	1800.0 ... 2240.0
X2	2240.0 ... 2850.0

Vf Binning (Optional)

Vf Bin @ 20mA	Forward Voltage (V) <small>Appx. 3.1</small>
V1	2.70 ... 3.00
V2	3.00 ... 3.30
V3	3.30 ... 3.60

Please consult sales and marketing for special part number to incorporate Vf binning.

Relative Luminous Intensity Vs Forward Current

$$I_v/I_v(20\text{mA}) = f(I_F); T_j = 25^\circ\text{C}$$

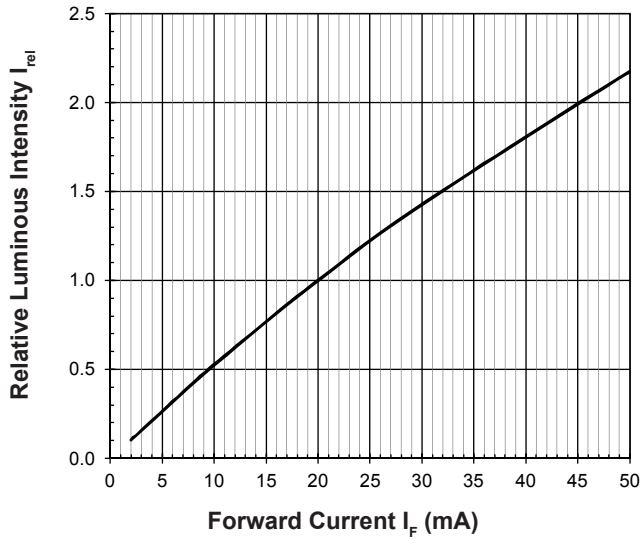

Forward Current Vs Forward Voltage

$$I_F = f(V_F); T_j = 25^\circ\text{C}$$

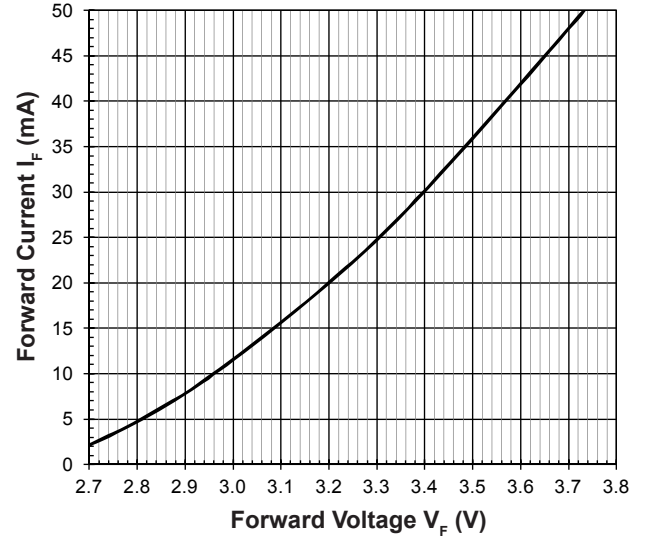

Maximum Current Vs Temperature

$$I_F = f(T)$$

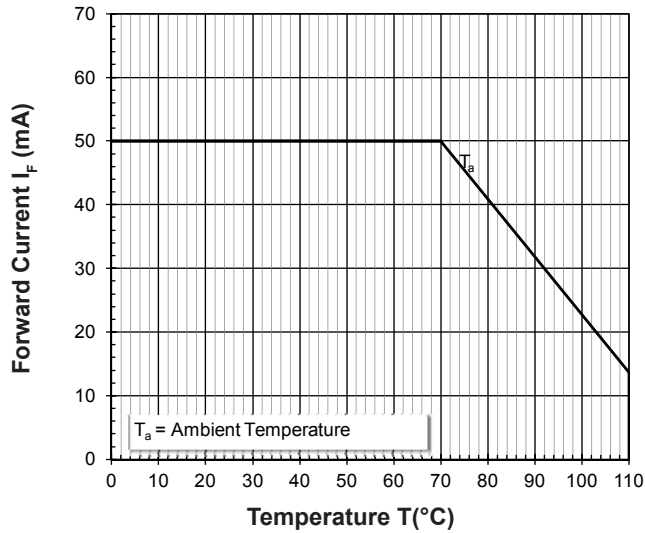

Relative Spectral Emission

$$I_{rel} = f(\lambda); T_j = 25^\circ\text{C}; I_F = 20\text{mA}$$

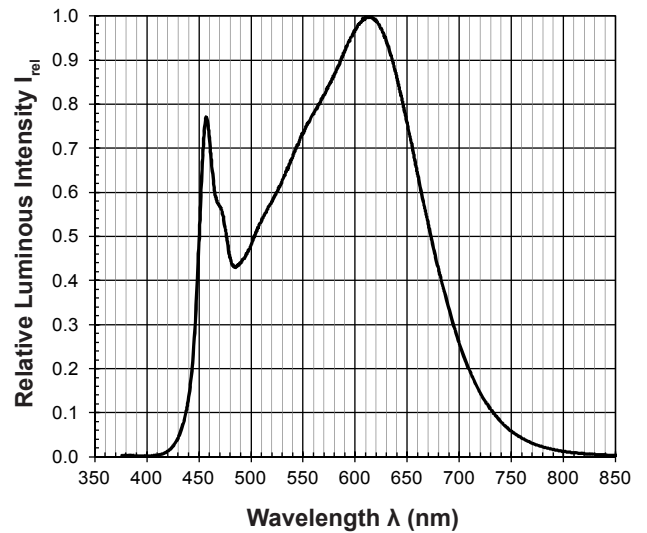

Chromaticity Coordinate Shift Vs Forward Current

$$\Delta Cx, \Delta Cy = f(I_F); T_j = 25^\circ\text{C}$$

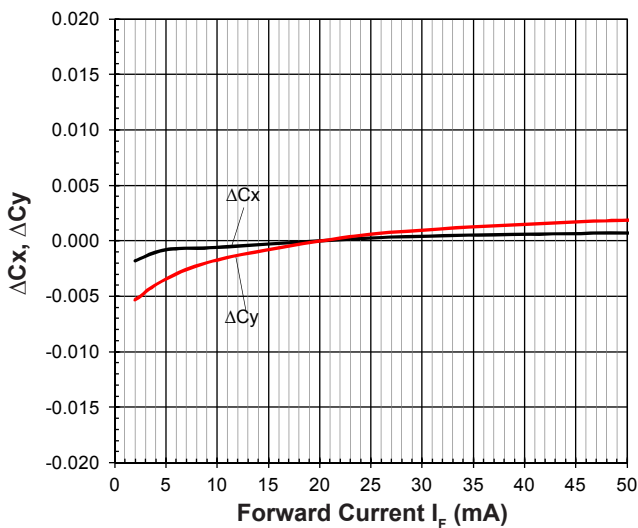

Allowable Forward Current Vs Duty Ratio

$$(T_j = 25^\circ\text{C}; t_p \leq 10\mu\text{s})$$

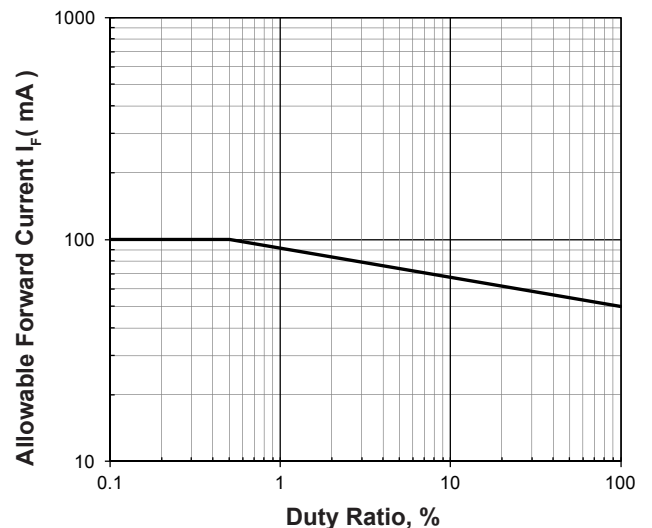

Radiation Pattern

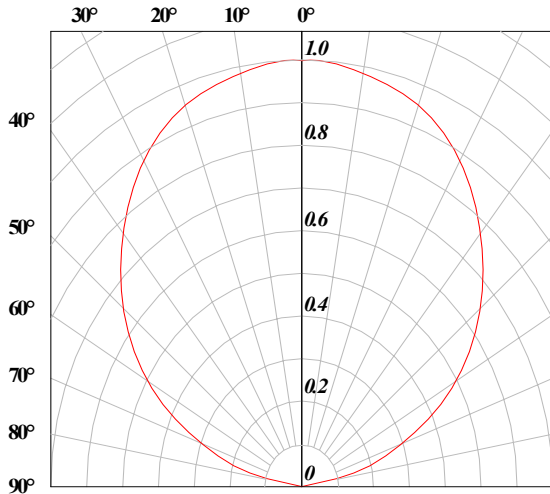

Forward Voltage Vs Junction Temperature

$$\Delta V_F = V_F - V_F(25^\circ\text{C}) = f(T_j); I_F = 20\text{mA}$$

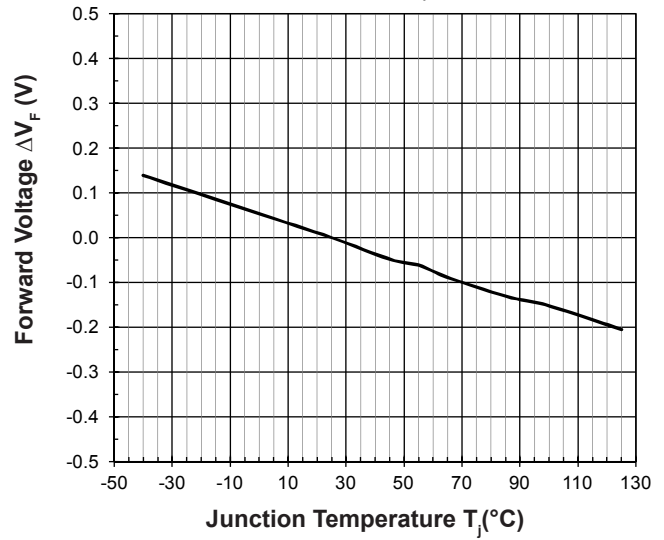

Relative Luminous Intensity Vs Junction Temperature

$$I_V/I_V(25^\circ\text{C}) = f(T_j); I_F = 20\text{mA}$$

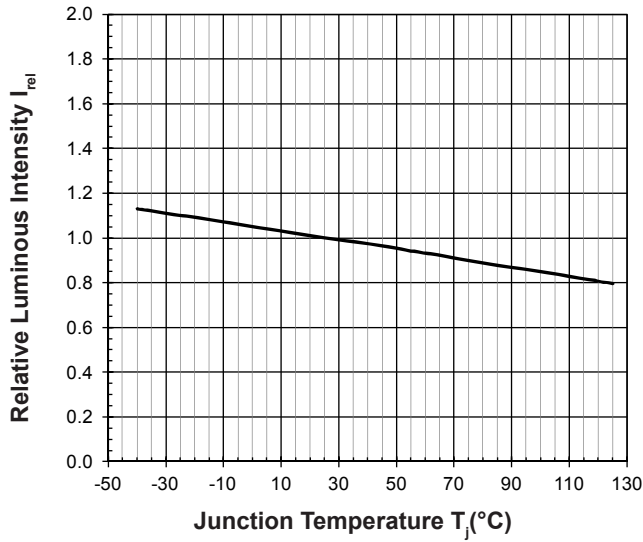

Chromaticity Coordinate Shift Vs Junction Temperature

$$\Delta C_x, \Delta C_y = f(T_j); I_F = 20\text{mA}$$

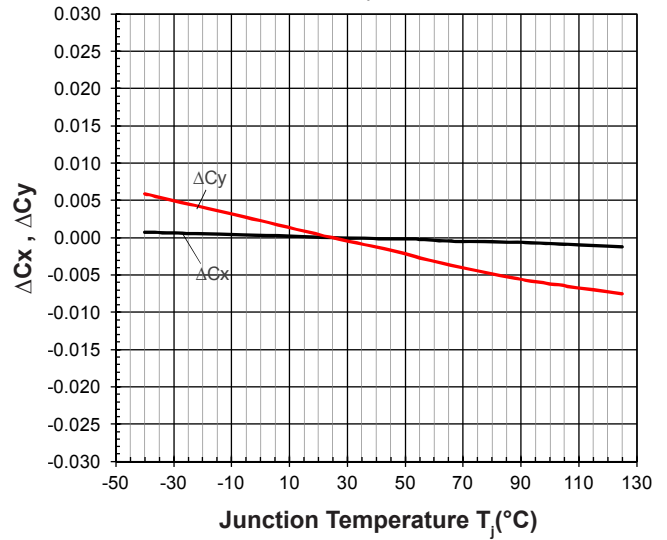

DomiLED • InGaN: DDF-NJJ Package Outlines

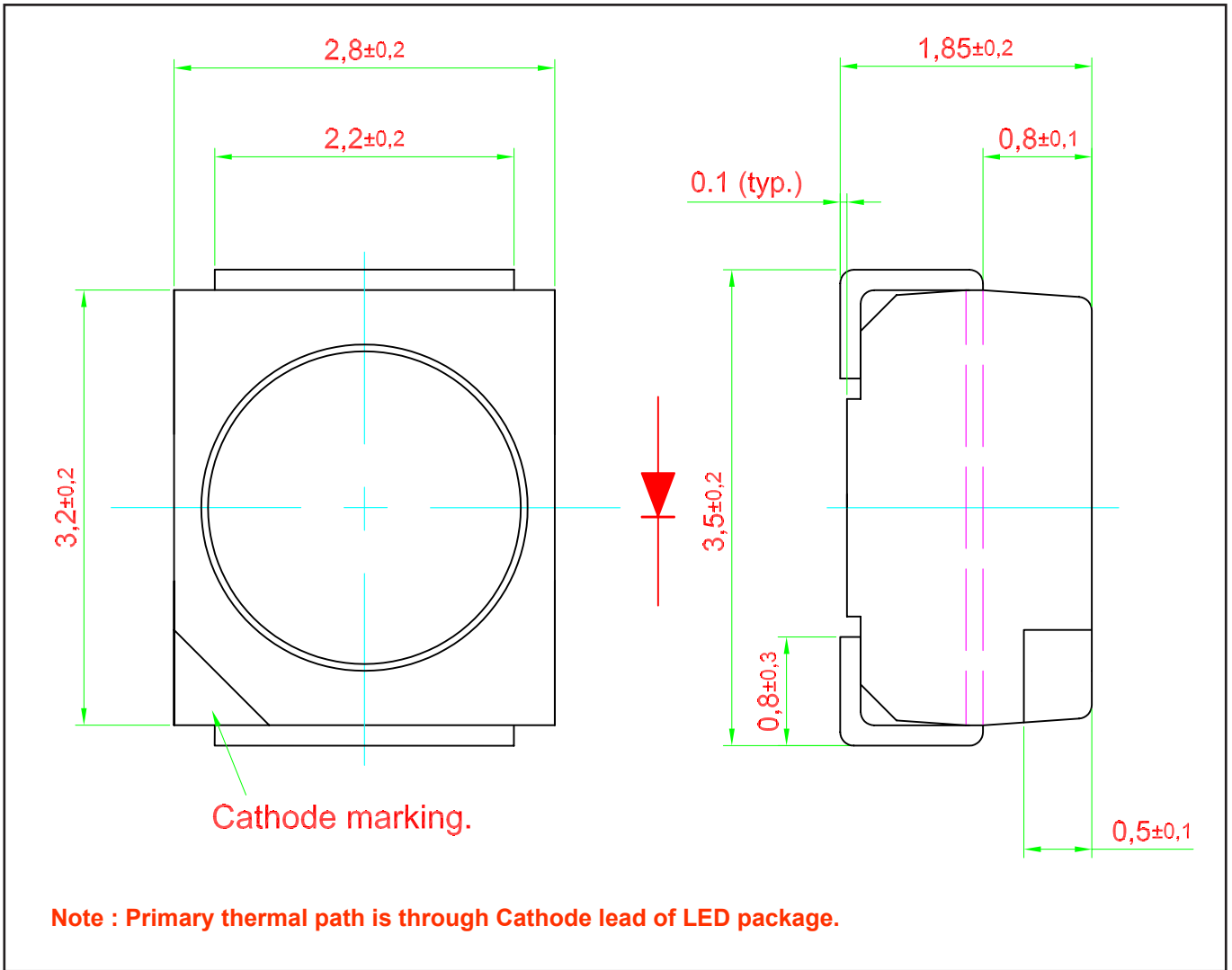

Material

	Material
Lead-frame	Cu Alloy With Ag Plating
Package	High Temperature Resistant Plastic, PPA
Encapsulant	Silicone Resin
Soldering Leads	Sn Plating

Recommended Solder Pad

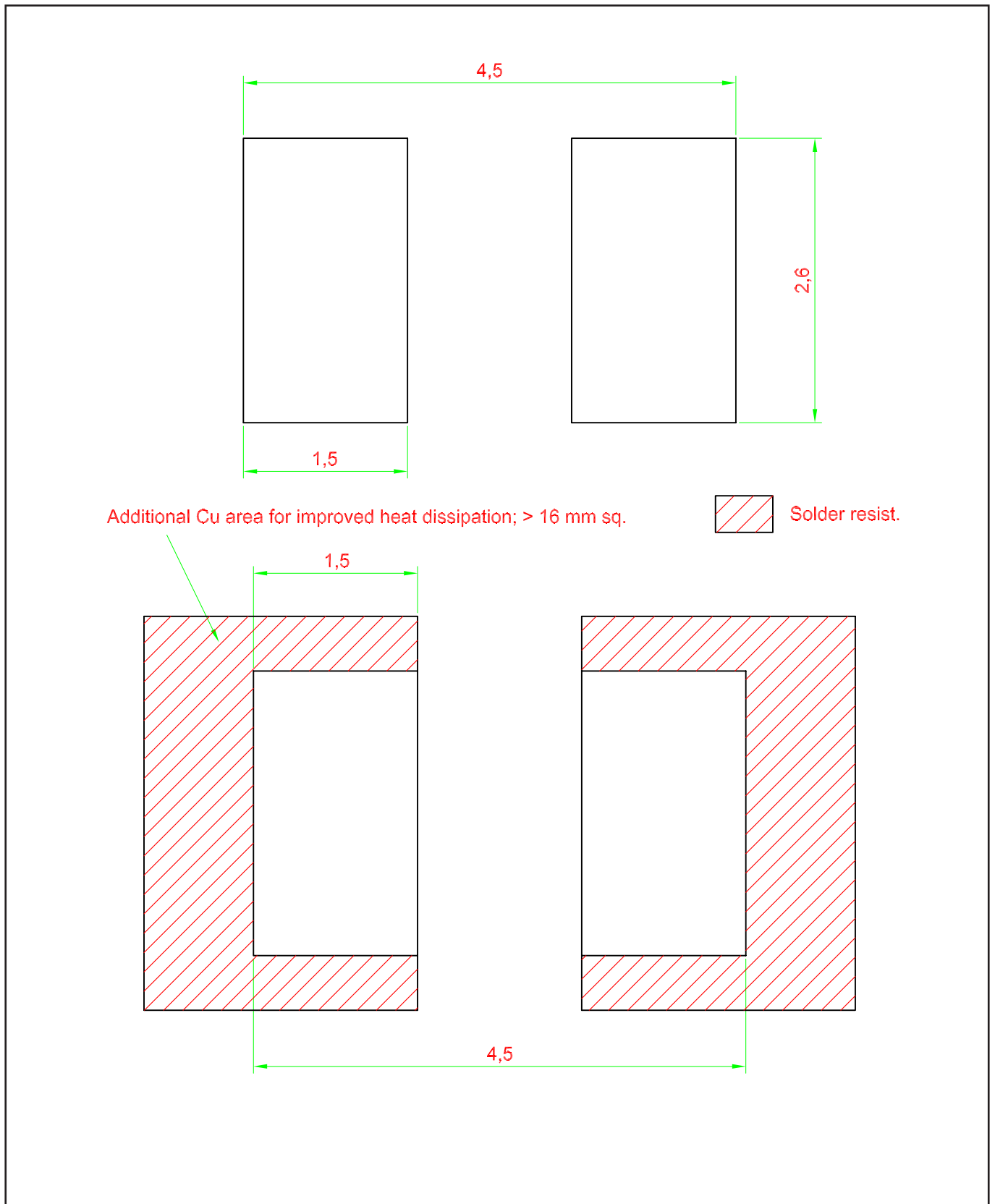

Taping and orientation

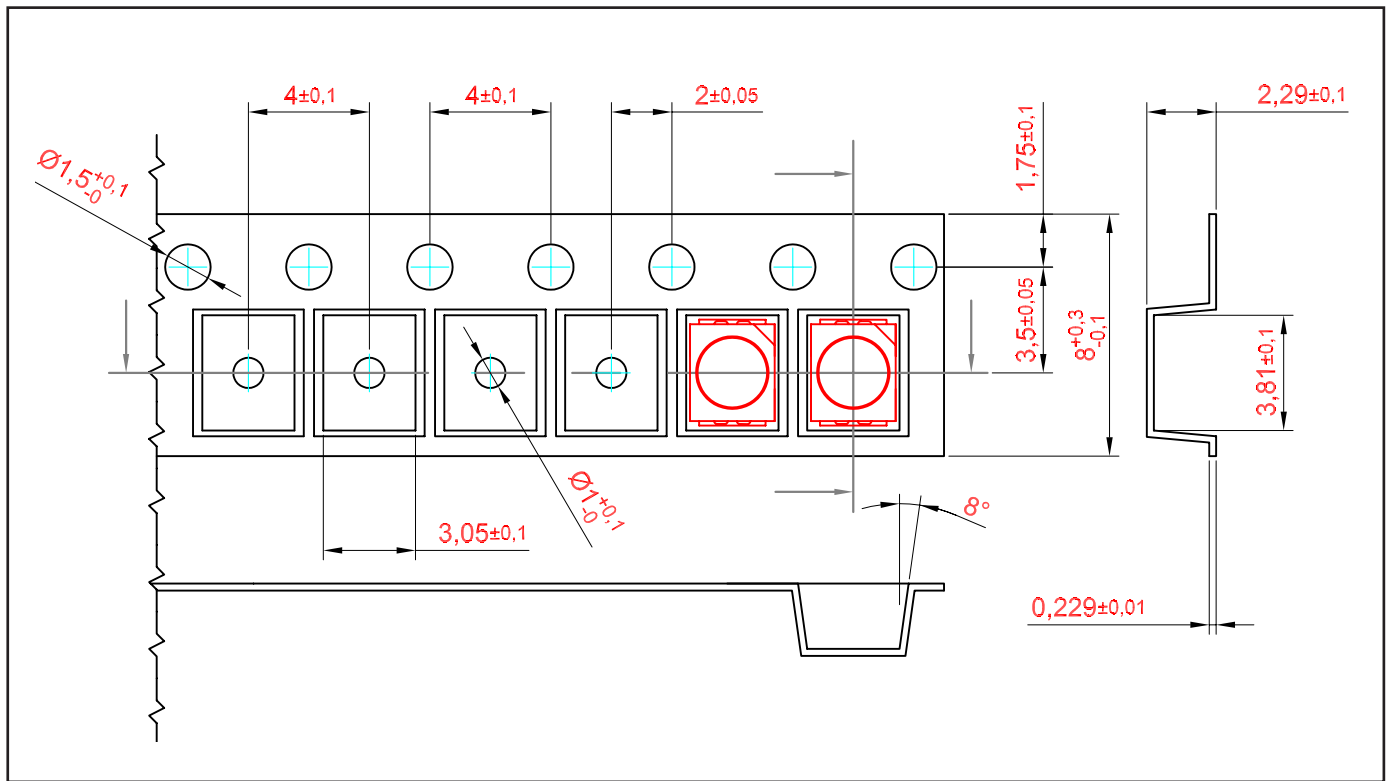

200 mm min. for $\varnothing 180$ reel.

480 mm min. for $\varnothing 180$ reel.

200 mm min. for $\varnothing 330$ reel.

960 mm min. for $\varnothing 330$ reel.

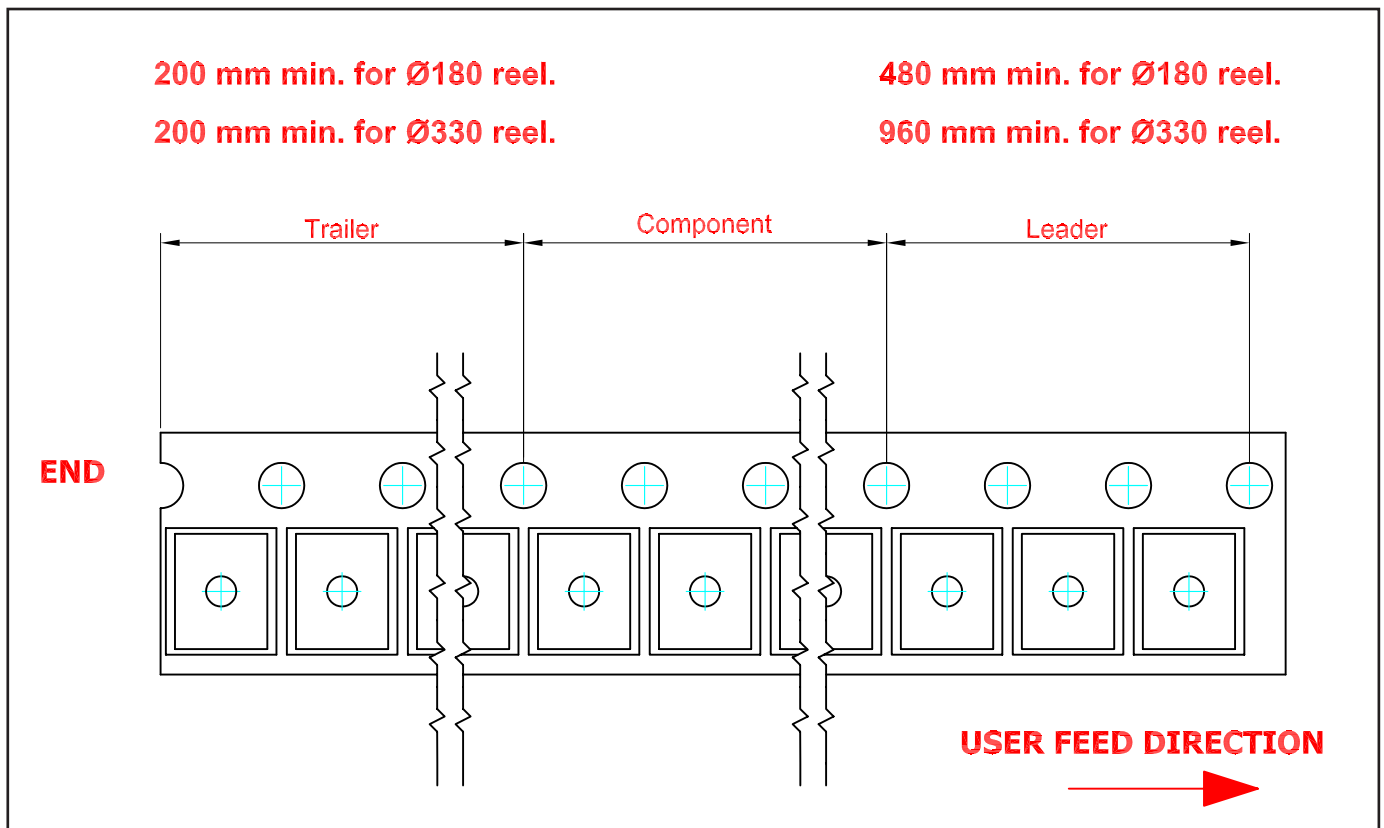

Packaging Specification

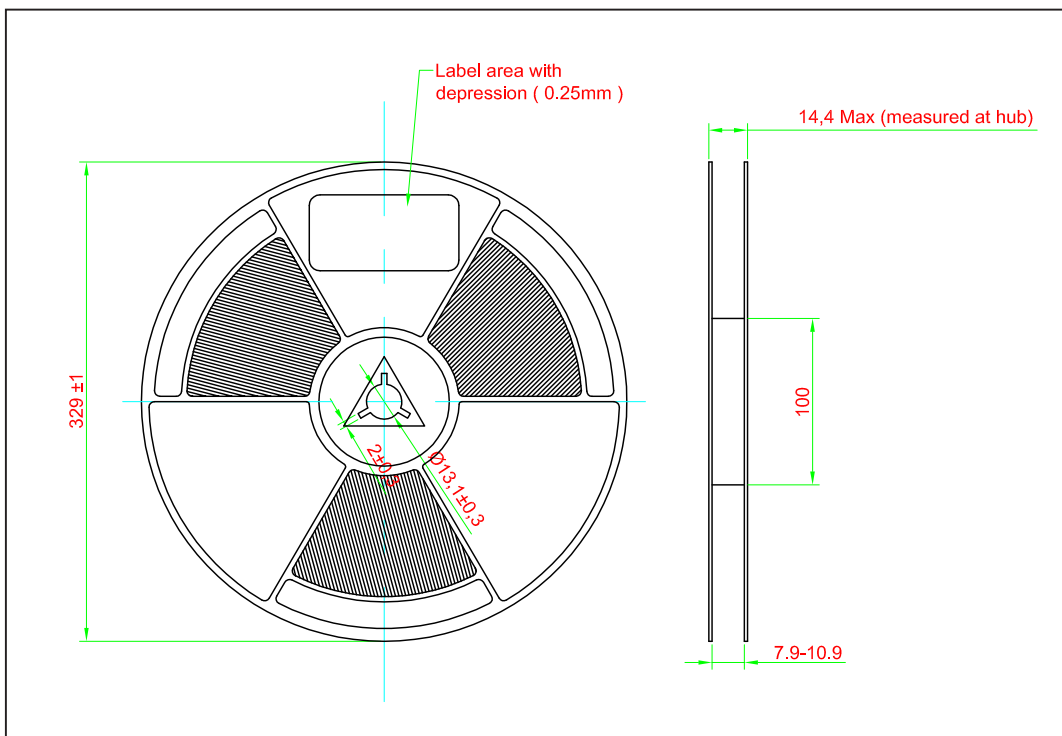
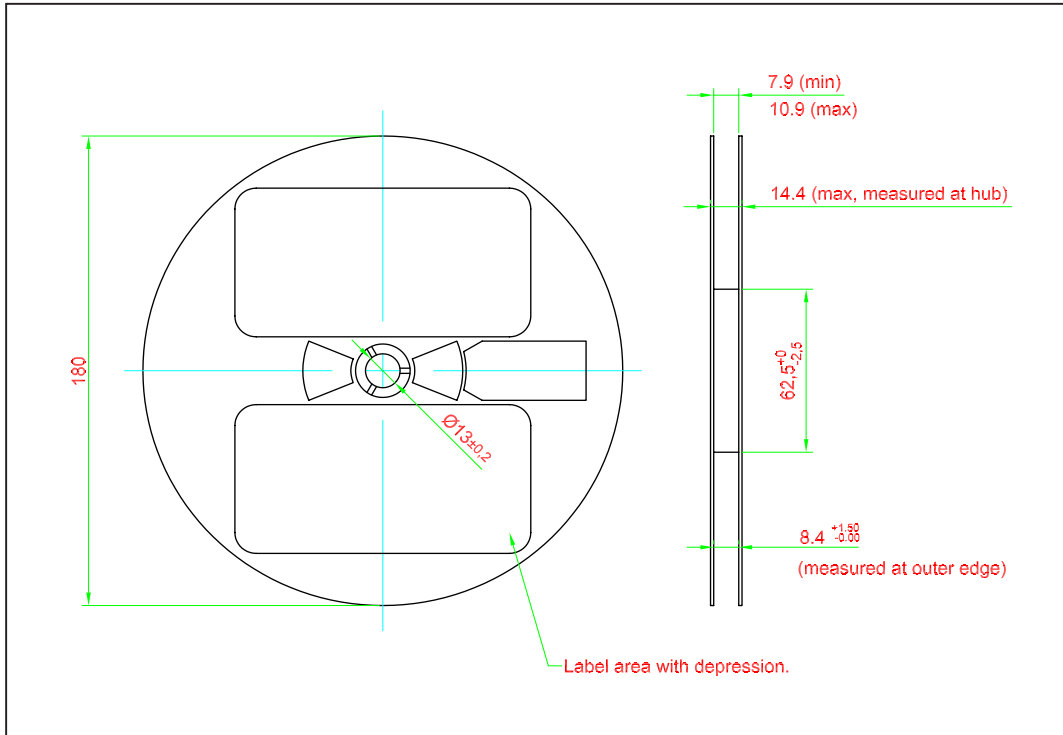

	Reel Diameter (mm)	Quantity (pcs)	*Ordering Number
Standard Packing	180	2000	DDF-NJJ-xxx-x
Optional Packing	329	8000	DDF-NJJ-xxx-x-8

Notes:

* For ordering purpose only. Please consult sales and marketing for details.

Packaging Specification

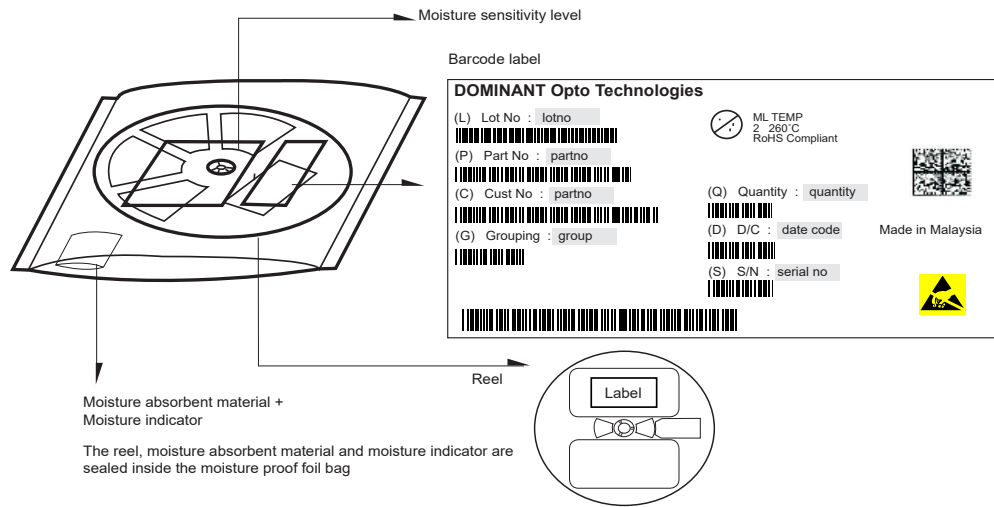

Quantity per bag (pcs)	Average 1pc DomiLED (g)	1 completed bag (g)
2000	0.034	240 ± 10
8000	0.034	750 ± 10

Recommended Pb-free Soldering Profile

Product complies to MSL Level 2 acc. to JEDEC J-STD-020E

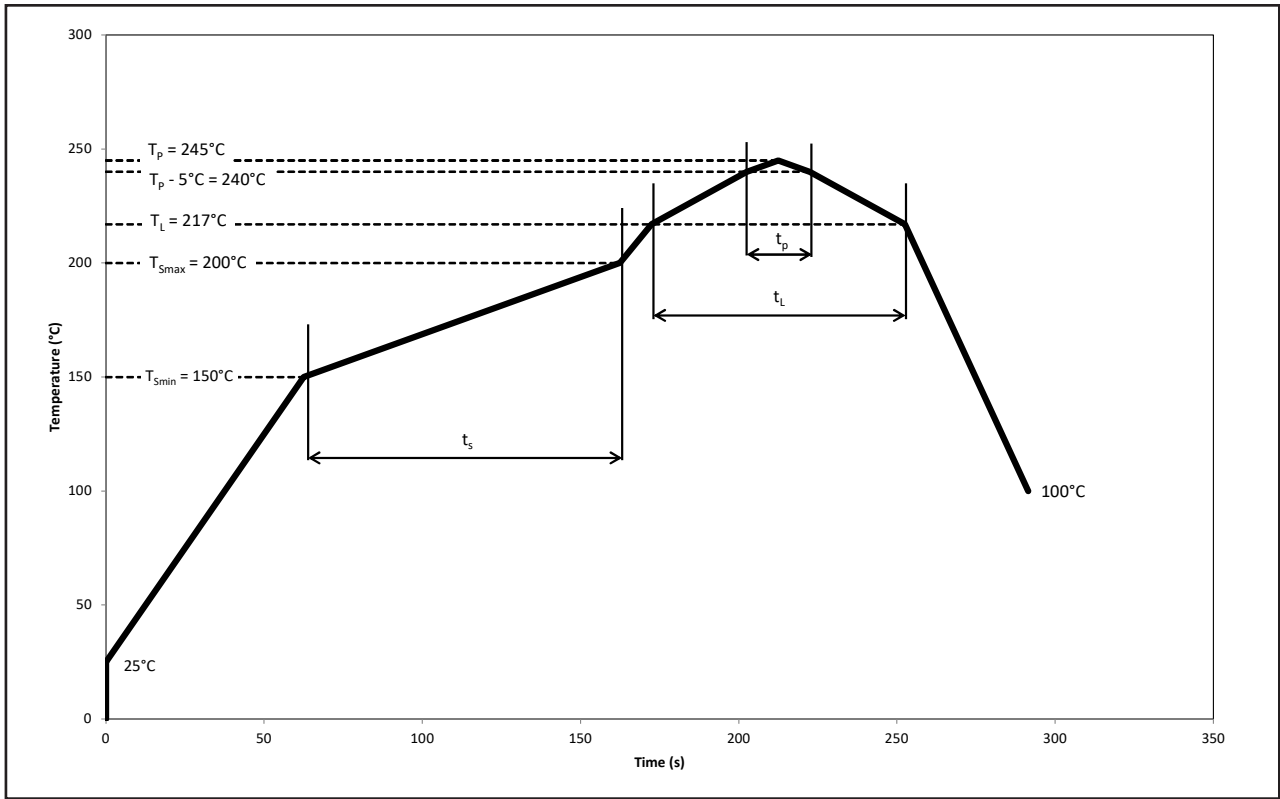

Profile Feature	Symbol	Pb-Free Assembly			Unit
		Min.	Recommended	Max.	
Ramp-up rate to preheat 25°C to T_{smin}	-	-	2	3	°C/s
Time t_s T_{smin} to T_{smax}	t_s	60	100	120	s
Ramp-up rate to peak T_L to T_p	-	-	2	3	°C/s
Liquidous temperature	T_L	-	217	-	°C
Time above liquidous temperature	t_L	60	80	150	s
Peak temperature	T_p	-	245	260	°C
Time within 5°C of the specified peak temperature $T_p - 5^\circ\text{C}$	t_p	10	20	30	s
Ramp-down rate T_p to 100°C	-	-	3	6	°C/s
Time 25°C to T_p	-	-	-	480	s

Appendix

1) **Brightness:**

- 1.1 Luminous intensity is measured at current pulse 25 ms(typ) with an internal reproducibility of $\pm 8\%$ and an expanded uncertainty of $\pm 11\%$ (according to GUM with a coverage factor of $k=3$).
- 1.2 Luminous flux is measured at current pulse 25 ms(typ) with an internal reproducibility of $\pm 8\%$ and an expanded uncertainty of $\pm 11\%$ (according to GUM with a coverage factor of $k=3$).
- 1.3 Radiant intensity is measured at current pulse 25 ms(typ) with an internal reproducibility of $\pm 8\%$ and an expanded uncertainty of $\pm 11\%$ (according to GUM with a coverage factor of $k=3$).
- 1.4 Radiant flux is measured at current pulse 25 ms(typ) with an internal reproducibility of $\pm 8\%$ and an expanded uncertainty of $\pm 11\%$ (according to GUM with a coverage factor of $k=3$).

2) **Color:**

- 2.1 Chromaticity coordinate groups are measured at current pulse 25 ms(typ) with an internal reproducibility of ± 0.005 and an expanded uncertainty of ± 0.01 (accordingly to GUM with a coverage factor of $k=3$).
- 2.2 Dominant wavelength is measured at current pulse 25 ms(typ) with an internal reproducibility of $\pm 0.5\text{nm}$ and an expanded uncertainty of $\pm 1\text{nm}$ (accordingly to GUM with a coverage factor of $k=3$).

3) **Voltage:**

- 3.1 Forward Voltage, V_f is measured when a current pulse of 8 ms(typ) with an internal reproducibility of $\pm 0.05\text{V}$ and an expanded uncertainty of $\pm 0.1\text{V}$ (accordingly to GUM with a coverage factor of $k=3$).

4) **Typical Values:**

- 4.1 At special conditions of LED manufacturing processes, typical data or calculated correlations of technical parameters only reflect the statistical figures. But not necessarily correspond to the actual parameters of each single product, which could differ from the typical data or calculated correlations or the typical characteristic line. These typical data may change whenever technical improvements happen.

5) **Tolerance of Measure**

- 5.1 Unless otherwise noted in drawing, tolerances are specified with ± 0.1 and dimension are specific in mm.

6) **Reverse Voltage:**

- 6.1 Not designed for reverse operation. Continuous reverse voltage can cause migration and LED damage.

Revision History

Page	Subjects	Date of Modification
-	Initial release	22 Jul 2016
12, 14	Update Packaging Specification Update Appendix	11 Dec 2018
2, 13, 14	Update Notes Add Test Condition for Thermal Resistance Update Packaging Specification	28 May 2019
14, 15	Update Packaging Specification Update Recommended Pb-free Soldering Profile	11 Jan 2024

NOTE

All the information contained in this document is considered to be reliable at the time of publishing. However, DOMINANT Opto Technologies does not assume any liability arising out of the application or use of any product described herein.

DOMINANT Opto Technologies reserves the right to make changes to any products in order to improve reliability, function or design.

DOMINANT Opto Technologies products are not authorized for use as critical components in life support devices or systems without the express written approval from the Managing Director of DOMINANT Opto Technologies.

Dispose of product is in accordance with local, regional, national and international regulations.

About Us

DOMINANT Opto Technologies is a dynamic company that is amongst the world's leading automotive LED manufacturers. With an extensive industry experience and relentless pursuit of innovation, DOMINANT's state-of-art manufacturing and development capabilities have become a trusted and reliable brand across the globe. More information about DOMINANT Opto Technologies, an IATF 16949 and ISO 14001 certified company, can be found under <http://www.dominant-semi.com>.

Please contact us for more information:

DOMINANT Opto Technologies Sdn. Bhd
Lot 6, Batu Berendam, FTZ Phase III, 75350 Melaka, Malaysia.
Tel: +606 283 3566 Fax: +606 283 0566
E-mail: sales@dominant-semi.com
